

CATALOGO RICAMBI SPARES CATALOGUE

125 LI 150 LI 175 TV

terza serie
third series
troisième série
dritte serie

Lambretta

CATALOGUE RECHANGES ERSATZTEILELISTE

125 S 150 S 150 SX 200 SX

INNOCENTI
DIVISIONE MOTORI

120
+

catalogo ricambi
spares catalogue
catalogue rechanges
ersatzteilleiste



I

II

III

IV

V

VI

VII

VIII

IX

X

XI

XII

XIII

XIV

XV

XVI

XVII

www.fpw.it

AVVERTENZE

Il presente Catalogo annulla e sostituisce i precedenti emessi con i seguenti N.ri di Pubblicazioni.

- Catalogo Pubbl. No. 36 - 3/1962.
- Supplemento No. 1 - Pubbl. No. 57 - 10/1963.
- Supplemento No. 2 - Pubbl. No. 68 - 10/1964.
- Supplemento No. 3 - Pubbl. No. 85 - 12/1965.
- Supplemento No. 4 - Pubbl. No. 86 - 12/1965.

ed inoltre tutte le informazioni di modifica relative.

Ogni tavola comprende apposite colonne che segnalano con | O | su quale modello di motoscooter è montato ogni particolare.
Dopo l'indice numerico, sono state aggiunte due tavole: una dei rapporti cambio e l'altra di regolazione per i vari tipi di carburatori.

NOTICE

The present catalogue cancels and supersedes the following publications:

- Catalogue Pub. No. 36 - 3/1962.
- Supplement No. 1 - Pub. No. 57 - 10/1963.
- Supplement No. 2 - Pub. No. 68 - 10/1964.
- Supplement No. 3 - Pub. No. 85 - 12/1965.
- Supplement No. 4 - Pub. No. 86 - 12/1965.

and furthermore all relating modification bulletins.

Each section includes special columns indicating with | O | to which scooter model each part is fitted.
After the numerical index, two sections have been added: one for the gearbox ratios and one for the adjustment of the various carburetors.

A V I S

Le présent catalogue annule et substitue les suivantes publications:

- Catalogue Pub. No. 36 - 3/1962.
- Supplément No. 1 - Pub. No. 57 - 10/1963.
- Supplément No. 2 - Pub. No. 68 - 10/1964.
- Supplément No. 3 - Pub. No. 85 - 12/1965.
- Supplément No. 4 - Pub. No. 86 - 12/1965.

et en outre tous les bulletins de modification relatifs.

Chaque planche comprend des colonnes spéciales indiquant avec | O | sur quel modèle de scooter chaque pièce est montée.
Après l'index numérique, deux planches ont été ajoutées: une pour les rapports de boîte de vitesses et une pour le réglage des divers carburateurs.

ANZEIGE

Die vorliegende Ersatzteilliste annulliert und ersetzt folgende Herausgaben:

- Ersatzteilliste Ausg. Nr. 36 - 3/1962.
- Supplement Nr. 1 - Ausg. Nr. 57 - 10/1963.
- Supplement Nr. 2 - Ausg. Nr. 68 - 10/1964.
- Supplement Nr. 3 - Ausg. Nr. 85 - 12/1965.
- Supplement Nr. 4 - Ausg. Nr. 86 - 12/1965.

und ausserdem alle bezüglichlichen Aenderungsmittelungen.

Jede Tafel enthält spezielle Spalten, die mit Zeichen | O | angeben auf welchem Roller-Modell jeder Teil montiert wird.
Nach der Nummeraufstellung sind zwei Tafeln hinzugefügt: eine für die Wechselgetriebe Übersetzungen und eine für die Einstellung der verschiedenen Vergaser.

www.rpw.it

	Indice delle tavole	Section index	Répertoire des planches	Tafelverzeichnis
—	Indice	Index	Index	Inhaltsverzeichnis
★	Rapporti cambio Regolazione carburatori	Gearbox ratios. Carburettor adjustment	Rapports de boîte de vitesses Réglage carburateurs	Wechselgetriebe-Übersetzungen Vergasereinstellung
I	Carter motore - cilindro	Crankcase - cylinder	Carter moteur - cylindre	Motorgehäuse - Zylinder
II	Manovellismo	Crankshaft - piston	Embielage	Kurbeltrieb
III	Frizione	Clutch	Embrayage	Kupplung
IV	Cambio - avviamento	Gearbox - starter	Boîte de vitesses - démarreur	Wechselgetriebe - Anlasser
V	Raffreddamento	Cooling system	Refroidissement	Kühlung
VI	Alimentazione - scarico	Fuel and exhaust system	Système d'aliment, et d'échappement	Kraftstoff - und Auspuffanlage
VII	Telaio - sospensione	Frame - suspension	Châssis - suspension	Fahrgestell - Federung
VIII	Manubrio - forcella - tachimetro	Handle bar - fork - speedometer	Guidon - fourche - compteur	Lenker - Gabel - Tachometer
IX	Ruote - freni	Wheels - brakes	Roues - freins	Räder - Bremsen
X	Freno a disco	Disc brake	Frein à disque	Scheibenbremse
XI	Fanaleria	Lighting	Illumination	Beleuchtung
XII	Apparecchiature elettriche	Electrical equipment	Appareillage électrique	Elektrische Ausrüstung
XIII	Volano magnete « Ducati » 4 poli	« Ducati » 4 poles flywheel magneto	Volant magnétique 4 pôles « Ducati »	« Ducati » 4-poliger Magnetzündler
XIV	Volano magnete « Ducati » 6 poli	« Ducati » 6 poles flywheel magneto	Volant magnétique 6 pôles « Ducati »	« Ducati » 6-poliger Magnetzündler
XV	Carrozzeria	Body	Carrosserie	Aufbau
XVI	Comandi	Controls	Commandes	Betätigungen
XVII	Accessori	Accessories	Accessoires	Zubehör

DELLORTO

N. Matricola Part. No. Ref. des pièces Bestell-Nr.	N. Matricola Part. No. Ref. des pièces Bestell-Nr.	Tavola Section Planche Tafel	N. Fig. Fig. No. N° Fig. Abb. Nr.	N. Matricola Part. No. Ref. des pièces Bestell-Nr.	N. Matricola Part. No. Ref. des pièces Bestell-Nr.	Tavola Section Planche Tafel	N. Fig. Fig. No. N° Fig. Abb. Nr.	N. Matricola Part. No. Ref. des pièces Bestell-Nr.	N. Matricola Part. No. Ref. des pièces Bestell-Nr.	Tavola Section Planche Tafel	N. Fig. Fig. No. N° Fig. Abb. Nr.
INNOCENTI	DELLORTO	—	—	INNOCENTI	DELLORTO	—	—	INNOCENTI	DELLORTO	—	—
00412038	2383-30	VI	13	00412298	4187-29	VI	5	00412351	3360-50-02	VI	32
00412048	2420-22	VI	9	00412299	4188-30	VI	4	00412353	3360-48-02	VI	32
00412049	1973-27	VI	21	00412321	4559-05	VI	19	00412358	1486-101-02	VI	33
00412053	2439-06	VI	23	00412328	5910-00-80	VI	34	00412394	4713-30	VI	2
00412054	1576-27	VI	25	00412329	5979-96	VI	36	00412396	5914-01-64	VI	16
00412054	1576-27	VI	38	00412330	5912-26	VI	11	00412398	5907-50-02	VI	18
00412055	1575-37	VI	26	00412331	5913-38	VI	3	00412402	5899-02-28	VI	31
00412062	1111-36	VI	6	00412333	5915-53	VI	14	00412404	3360-4502	VI	32
00412071	2646-24	VI	22	00412337	5922-30	VI	35	00412407	1486-103-02	VI	33
00412140	3238-64	VI	41	00412338	5951-61	VI	15	00412408	1486-107-02	VI	33
00412148	1104-37	VI	37	00412339	5899-01-28	VI	31	00412435	1486-98-02	VI	33
00412181	3128-34	VI	39	00412341	3370-36	VI	1	00412436	5899-05-28	VI	31
00412182	3133-61	VI	40	00412342	4956-36	VI	27	00412437	5914-02-64	VI	16
00412191	2034-61	VI	12	00412343	3357-37	VI	29	00412440	1486-102-02	VI	33
00412192	3997-37	VI	10	00412344	3606-61	VI	30	00412441	SH1/18	VI	—
00412193	3978-36	VI	24	00412346	3360-42-02	VI	32	00412442	SH1/20	VI	—
00412248	1723-50	VI	7	00412347	1486-106-02	VI	33	00412443	SH1/20	VI	—
00412256	1486-105-02	VI	33	00412348	1486-99-02	VI	33	00412444	5899-04-28	VI	31
00412261	4416-62	VI	17	00412349	5971-22	VI	20				

BORLETTI

INNOCENTI	BORLETTI	—	—	INNOCENTI	BORLETTI	—	—	INNOCENTI	BORLETTI	—	—
00611015	PL-055/B	VIII	64	00611061	6136119901	VIII	61	00611070	6146149901	VIII	61
00611039	57900X1152	VIII	56	00611062	6146119901	VIII	61	00611071	6136149902	VIII	61
00611040	TR-1003-M1	VIII	58	00611063	6136119902	VIII	61	00611072	6146149902	VIII	61
00611041	TR-025-006	VIII	57	00611064	6146119902	VIII	61	00611073	6136149900	VIII	61
00611044	RV-437-M2	IX	34	00611065	6136110080	VIII	59	00611074	6146149900	VIII	61
00611044	RV-437-M2	X	19	00611066	9020003036	VIII	60	00611075	TR1036X1154	VIII	55
00611058	RV-453	IX	47	00611068	TR1011X1120	VIII	55	00611076	TR-1036/M1X1154	VIII	55
00611058	RV-453	X	29	00611069	6136149901	VIII	61	00611096	6136269900	VIII	61
								00611097	6146269900	VIII	61

www.pw.it

DUCATI

N. Matricola Part. No. Ref. des pièces Bestell-Nr.	N. Matricola Part. No. Ref. des pièces Bestell-Nr.	Tavola Section Planche Tafel	N. Fig. Fig. No. N° Fig. Abb. Nr.	N. Matricola Part. No. Ref. des pièces Bestell-Nr.	N. Matricola Part. No. Ref. des pièces Bestell-Nr.	Tavola Section Planche Tafel	N. Fig. Fig. No. N° Fig. Abb. Nr.	N. Matricola Part. No. Ref. des pièces Bestell-Nr.	N. Matricola Part. No. Ref. des pièces Bestell-Nr.	Tavola Section Planche Tafel	N. Fig. Fig. No. N° Fig. Abb. Nr.
INNOCENTI	DUCATI	—	—	INNOCENTI	DUCATI	—	—	INNOCENTI	DUCATI	—	—
00840013	31.43.41	XIII	—	00840058	31.95.065	XIV	2	00840081	31.95.220	XIV	8
00840015	31.95.298	XIII	5	00840058	31.95.065	XIV	10	00840082	32.61.06	XIII	21
00840017	31.95.141	XIII	10	00840058	31.95.065	XIV	14	00840082	32.61.06	XIV	25
00840018	31.95.142	XIII	1	00840059	31.95.066	XIV	12	00840083	31.46.42	XIV	—
00840019	31.95.297	XIII	3	00840060	11.30.21	XIV	4	00840084	31.95.227	XIV	9
00840040	31.95.301	XIII	1	00840069	31.95.078	XIII	16	00840085	31.95.228	XIV	7
00840041	31.95.300	XIII	5	00840069	31.95.078	XIV	21	00840087	31.95.229	XIV	17
00840042	31.43.42	XIII	—	00840070	31.95.079	XIII	15	00840088	31.46.43	XIV	—
00840049	11.30.10	XIII	8	00840070	31.95.079	XIV	22	00840102	—	XIV	1
00840050	31.43.44	XIII	—	00840072	31.95.177	XIII	9	00840103	—	XIV	1
00840051	31.95.303	XIII	10	00840074	31.95.217	XIV	9	00840159	—	XIII	4
00840052	31.95.304	XIII	1	00840077	31.95.221	XIV	16	00840160	—	XIII	4
00840057	31.95.064	XIV	18	00840078	31.95.219	XIV	17	00840161	—	XIII	4
00840058	31.95.065	XIII	6	00840079	31.95.225	XIV	15	00840163	31.95.556	XIV	8

www.fpw.it

INDICE - INDEX - INHALTSVERZEICHNIS
★
I
II
III
IV
V
VI
VII
VIII
IX
X
XI
XII
XIII
XIV
XV
XV

INDICE - INDEX - INHALTSVERZEICHNIS

N. Matricola Part. No. Réf. des pièces Bestell-Nr.	Tavola Section Planche Tafel	N. Figura Fig. No. N° figure Abb. Nr.	N. Matricola Part. No. Réf. des pièces Bestell-Nr.	Tavola Section Planche Tafel	N. Figura Fig. No. N° figure Abb. Nr.	N. Matricola Part. No. Réf. des pièces Bestell-Nr.	Tavola Section Planche Tafel	N. Figura Fig. No. N° figure Abb. Nr.	N. Matricola Part. No. Réf. des pièces Bestell-Nr.	Tavola Section Planche Tafel	N. Figura Fig. No. N° figure Abb. Nr.	N. Matricola Part. No. Réf. des pièces Bestell-Nr.	Tavola Section Planche Tafel	N. Figura Fig. No. N° figure Abb. Nr.
00205501	VII	7	15044019	IX	14	15057020	VII	32	15088003	VIII	38	19012016	III	34
00205501	VIII	28	15044022	IX	26	15059003	XVI	59	15088006	VIII	26	19012017	III	25
00205501	XII	36	15044022	IX	50	15059006	XVI	52	19010006	I	14	19012018	II	19
15010090	I	36	15044023	IX	4	15059009	XVI	19	19010007	I	51	19012031	II	7
15015009	VI	86	15044023	IX	42	15059012	XVI	43	19010008	I	15	19012034	II	11
15015015	VI	82	15044024	IX	10	15059013	XVI	57	19010008	I	30	19012036	II	13
15017006	XI	15	15044024	IX	28	15059014	XVI	58	19010009	I	12	19012037	II	12
15017006	XVI	55	15044028	IX	46	15059022	XVI	56	19010011	I	2	19012038	II	10
15017007	XII	41	15044028	X	18	15060020	VIII	82	19010012	I	47	19012039	II	9
15017013	XII	12	15044036	IX	65	15060032	VIII	75	19010015	V	2	19012041	II	8
15017040	XII	15	15044038	IX	11	15060070	VIII	79	19010016	IV	17	19012042	III	26
15017070	XII	10	15044038	IX	27	15061018	VIII	31	19010019	I	8	19012043	III	27
15022008	XVI	6	15044040	IX	2	15061019	VIII	33	19010022	I	7	19012130	II	2
15022008	XVI	12	15044040	IX	44	15061021	VIII	35	19010026	I	6	19014003	V	7
15022009	XVI	4	15044041	IX	45	15061024	VII	29	19010027	I	24	19014003	V	9
15022011	XVI	5	15044044	IX	25	15061060	VIII	34	19010028	I	53	19014030	V	5
15041024	I	33	15044044	IX	51	15062012	VIII	17	19010029	I	54	19015019	VI	97
15044004	X	14	15044070	IX	16	15062013	VIII	13	19010030	I	9	19015021	VI	81
15044005	IX	31	15044070	IX	60	15062014	VIII	42	19010035	I	26	19015022	VI	80
15044005	IX	53	15044070	X	16	15062015	VIII	10	19010036	I	25	19015023	VI	79
15044005	X	26	15044070	X	21	15062023	VIII	13	19010044	I	5	19015050	VI	78
15044005	X	33	15044070	X	38	15065004	XVI	69	19010050	I	13	19016024	VI	93
15044006	IX	52	15044100	IX	63	15065005	XVI	67	19010052	V	1	19016029	VI	67
15044006	X	34	15044100	X	45	15065006	XVI	15	19010053	I	10	19016037	VI	103
15044007	IX	33	15044110	IX	40	15065006	XVI	68	19010056	I	42	19016039	VI	104
15044007	IX	56	15044110	X	47	15065008	XVI	75	19010120	I	55	19016058	VI	73
15044007	X	42	15050052	XV	15	15065020	XVI	65	19010130	I	31	19016059	VI	88
15044011	IX	32	15050052	XV	41	15070013	VI	49	19010160	I	1	19016062	VI	92
15044011	IX	57	15050052	XV	50	15070014	VI	50	19011003	I	49	19016270	VI	91
15044011	X	27	15050058	XV	55	15070019	VI	55	19011008	I	46	19017014	XIII	2
15044011	X	36	15050066	XV	89	15070021	VI	43	19011009	VI	74	19017016	XII	11
15044014	IX	17	15050066	XV	92	15071002	VII	27	19011012	I	44	19017017	XI	39
15044014	IX	59	15050160	XVII	50	15082020	XII	6	19011013	I	45	19017018	XII	40
15044014	X	15	15050200	XVII	53	15086006	XV	66	19011020	I	43	19018001	VI	106
15044014	X	22	15055033	VII	3	15086008	XV	67	19012006	II	5	19018003	VI	109
15044014	X	39	15055040	VII	2	15086015	XV	46	19012007	II	6	19020015	III	27
15044015	X	20	15055059	VII	23	15086016	XV	45	19012008	II	3	19020016	III	10
15044017	IX	15	15055170	XVII	13	15086017	XV	75	19012013	III	28	19020018	III	8
15044018	IX	30	15057009	VII	33	15086061	XVII	28	19012015	III	35	19020021	III	17

www.fpw.it

INDICE - INDEX - INHALTSVERZEICHNIS

N. Matricola Part. No. Réf. des pièces Bestell-Nr.	Tavola Section Planche Tafel	N. Figura Fig. No. N° figure Abb. Nr.	N. Matricola Part. No. Réf. des pièces Bestell-Nr.	Tavola Section Planche Tafel	N. Figura Fig. No. N° figure Abb. Nr.	N. Matricola Part. No. Réf. des pièces Bestell-Nr.	Tavola Section Planche Tafel	N. Figura Fig. No. N° figure Abb. Nr.	N. Matricola Part. No. Réf. des pièces Bestell-Nr.	Tavola Section Planche Tafel	N. Figura Fig. No. N° figure Abb. Nr.	N. Matricola Part. No. Réf. des pièces Bestell-Nr.	Tavola Section Planche Tafel	N. Figura Fig. No. N° figure Abb. Nr.
19020022	III	29	19030036	IV	43	19044002	IX	41	19058019	VII	13	19071007	VI	57
19020032	III	29	19030038	I	4	19044002	IX	43	19058090	VII	11	19071008	VI	56
19020033	III	29	19030039	I	3	19044002	X	37	19059001	XVI	2	19071009	VI	65
19020034	III	29	19030040	I	19	19044004	IX	21	19059003	XVI	3	19071011	VI	64
19020035	III	29	19030043	IV	38	19044013	IX	20	19059003	XVI	66	19071012	VI	59
19020050	III	16	19030044	IV	22	19044034	IX	61	19059005	XVI	17	19071013	VI	58
19020070	III	23	19030045	III	20	19044034	X	43	19059006	XVI	38	19071014	VI	63
19020080	III	19	19030046	IV	16	19044037	IX	66	19059011	XVI	20	19071015	VI	62
19021001	III	9	19030047	IV	21	19044050	IX	29	19059015	XVI	16	19071016	VI	61
19021002	III	13	19030048	IV	21	19044060	IX	62	19059016	XVI	18	19081033	XII	30
19021004	III	6	19030050	IV	42	19044060	X	44	19059017	XVI	51	19081045	XII	56
19021006	III	2	19031002	IV	37	19044140	IX	13	19059019	IX	8	19081048	XII	44
19021007	III	3	19031003	XVI	13	19045003	IX	3	19059021	IX	7	19081380	XII	31
19022014	XVI	23	19031004	XVI	33	19045004	IX	6	19059050	XVI	1	19081390	XII	55
19022015	XVI	34	19031006	XVI	32	19045005	IX	23	19060014	VIII	93	19081410	XII	16
19022016	XVI	72	19031008	IV	32	19045013	IX	35	19060015	VIII	77	19082050	XI	13
19022030	XVI	28	19031012	XVI	11	19045014	IX	37	19060016	VIII	78	19082130	XI	14
19022040	XVI	9	19031013	III	7	19045015	IX	38	19060017	VIII	80	19083180	XI	3
19030001	IV	30	19031013	IV	46	19045060	IX	36	19060021	VIII	66	19086018	XV	71
19030002	IV	33	19031014	IV	34	19050097	XV	57	19060028	VIII	83	19086067	XVII	27
19030003	IV	25	19031015	III	5	19050097	XV	80	19060090	VIII	76	19090018	XVI	42
19030004	IV	26	19031015	III	11	19050098	XV	18	19060230	XVII	43	19111003	I	49
19030005	IV	27	19031015	IV	47	19050098	XV	31	19060240	XVII	45	19111015	I	48
19030006	IV	28	19031015	IX	5	19050098	XV	44	19060250	XVII	45	19112018	II	19
19030007	III	22	19031017	XVI	37	19050098	XV	81	19060280	VIII	71	19130013	IV	30
19030014	IV	8	19032001	XVI	25	19050098	XVII	61	19060280	XVII	46	19130014	IV	25
19030015	IV	12	19032001	XVI	27	19050099	XV	83	19060290	VIII	69	19130015	IV	26
19030016	IV	11	19032003	XVI	14	19050104	XV	42	19060290	XVII	44	19130016	IV	27
19030017	IV	13	19032005	XVI	8	19050111	XV	19	19061023	VII	30	19130017	IV	28
19030018	IV	6	19032007	XVI	7	19050111	XV	24	19061025	VIII	32	19130042	IV	20
19030020	IV	14	19032008	XVI	22	19050111	XV	26	19061110	VIII	48	19150200	XVII	51
19030021	I	20	19032008	XVI	26	19050111	XV	37	19062002	VIII	21	19181380	XII	31
19030023	IV	21	19032016	XVI	39	19050111	XV	51	19062003	VIII	23	19181390	XII	55
19030025	I	29	19032050	XVI	40	19050200	XVII	52	19062004	VIII	22	19210013	I	11
19030026	I	28	19032060	XVI	29	19055056	XVII	9	19062019	VIII	25	19210014	I	11
19030028	IV	18	19041022	III	31	19055056	XVII	40	19062021	VIII	24	19211003	I	49
19030032	IV	44	19041090	III	24	19055250	XVII	3	19065060	XVI	71	19211017	VI	77
19030033	IV	23	19041100	III	32	19055290	XVII	2	19065070,	XVI	70	19212018	II	19
19030034	IV	1	19041110	III	33	19058017	VII	12	19070011	VI	48	19212140	II	1
19030035	I	21	19041130	III	24	19058018	VII	14	19070040	VI	42	19214020	V	10

www.ofpww.com

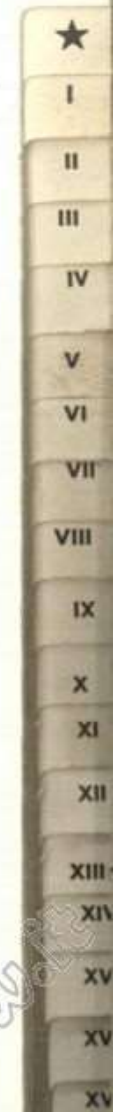

INDICE - INDEX - INHALTSVERZEICHNIS

N. Matricola Part. No. Réf. des pièces Bestell-Nr.	Tavola Section Planche Tafel	N. Figura Fig. No. № figure Abb. Nr.	N. Matricola Part. No. Réf. des pièces Bestell-Nr.	Tavola Section Planche Tafel	N. Figura Fig. No. № figure Abb. Nr.	N. Matricola Part. No. Réf. des pièces Bestell-Nr.	Tavola Section Planche Tafel	N. Figura Fig. No. № figure Abb. Nr.	N. Matricola Part. No. Réf. des pièces Bestell-Nr.	Tavola Section Planche Tafel	N. Figura Fig. No. № figure Abb. Nr.	N. Matricola Part. No. Réf. des pièces Bestell-Nr.	Tavola Section Planche Tafel	N. Figura Fig. No. № figure Abb. Nr.
19220015	III	21	19550160	XVII	58	19711015	I	48	19755180	XV	28	19915020	VI	85
19222012	VIII	16	19550170	XVII	57	19711020	I	43	19755190	XV	11	19915030	XVI	54
19230001	IV	30	19550503	XVII	60	19711030	I	43	19760010	VIII	81	19915070	VI	84
19230003	IV	25	19550504	XV	104	19712024	II	17	19760050	VIII	90	19916018	VI	89
19230004	IV	26	19550520	XVII	49	19712025	II	17	19760060	VIII	89	19916019	VI	54
19230005	IV	27	19550530	XV	86	19712026	II	17	19760100	VIII	79	19916021	VI	100
19230006	IV	28	19550540	XVII	59	19712027	II	17	19761010	VIII	43	19916036	VI	102
19250071	XVII	47	19550580	VII	1	19712090	II	18	19761020	VIII	36	19916042	VI	70
19281230	XII	29	19555140	XVII	12	19712100	II	18	19761030	VIII	43	19916051	VI	71
19411004	VI	76	19555150	XVII	12	19712110	II	18	19762030	VIII	4	19916057	VI	90
19411015	I	48	19555160	XVII	12	19712120	II	18	19762080	VIII	4	19916061	VI	94
19411020	I	43	19581500	XII	49	19744047	X	32	19763006	VIII	20	19916150	VI	96
19411030	I	43	19581501	XII	50	19744048	X	31	19780001	XI	20	19916160	VI	99
19412045	II	17	19581502	XII	52	19744049	X	30	19780007	XI	19	19916250	VI	72
19412046	II	17	19610160	I	1	19744051	X	17	19780008	XI	23	19917023	XII	13
19412047	II	17	19611004	VI	76	19744053	X	28	19780009	XI	22	19917024	XIII	17
19412048	II	17	19611012	I	44	19744054	X	8	19780010	XI	—	19917024	XIV	20
19412150	II	18	19611017	VI	77	19744055	X	7	19780011	XI	21	19917025	XIII	18
19412160	II	18	19611020	I	43	19744056	X	2	19780012	XI	19	19917025	XIV	19
19412170	II	18	19611050	I	43	19744057	X	5	19780050	XI	16	19917092	XIII	19
19412180	II	18	19612018	II	19	19744058	X	4	19780070	XI	16	19917092	XIV	23
19430007	IV	30	19612150	II	1	19744064	X	6	19781001	XII	34	19917093	XIII	22
19430008	IV	25	19612270	II	18	19744066	X	3	19781040	XII	35	19917093	XIV	26
19430009	IV	26	19612280	II	18	19744067	X	50	19781050	XII	35	19918060	VI	105
19430011	IV	27	19612290	II	18	19744068	X	51	19781070	XII	35	19920036	III	18
19430012	IV	28	19612300	II	18	19744072	X	23	19830001	IV	30	19920120	III	15
19450190	XVII	54	19630029	IV	19	19744074	X	49	19830005	IV	27	19930029	IV	19
19510060	I	13	19650170	XVII	55	19744160	X	25	19830009	IV	26	19930031	IV	15
19511020	I	43	19650190	XVII	48	19744170	X	11	19881040	XII	33	19931018	IV	45
19511050	I	43	19655076	XVII	37	19744180	X	1	19910020	I	27	19932025	XVI	41
19511510	I	43	19655077	XVII	37	19744190	X	10	19911004	VI	76	19944160	IX	49
19511520	I	43	19655150	XVII	12	19744200	X	12	19911015	I	48	19945110	IX	1
19518010	VI	107	19655180	XV	28	19750044	XV	85	19911017	VI	77	19950021	VII	38
19518510	VI	105	19655190	XV	11	19750045	XV	85	19911050	I	43	19950030	VII	1
19530501	IV	30	19681500	XII	49	19750083	XV	104	19912011	II	20	19950032	VII	19
19544009	IX	55	19710028	I	53	19750086	XV	100	19912190	II	1	19950044	XV	85
19544009	X	41	19710029	I	54	19755074	XVII	24	19912200	II	18	19950045	XV	85
19550060	XV	86	19710030	I	9	19755075	XVII	24	19912210	II	18	19950046	XV	87
19550110	XV	94	19710160	I	1	19755076	XVII	38	19912220	II	18	19950047	XV	99
19550150	XVII	56	19711004	VI	76	19755077	XVII	38	19912230	II	18	19950049	XV	91

INDICE - INDEX - INHALTSVERZEICHNIS

N. Matricola Part. No. Réf. des pièces Bestell-Nr.	Tavola Section Planche Tafel	N. Figura Fig. No. № figure Abb. Nr.	N. Matricola Part. No. Réf. des pièces Bestell-Nr.	Tavola Section Planche Tafel	N. Figura Fig. No. № figure Abb. Nr.	N. Matricola Part. No. Réf. des pièces Bestell-Nr.	Tavola Section Planche Tafel	N. Figura Fig. No. № figure Abb. Nr.	N. Matricola Part. No. Réf. des pièces Bestell-Nr.	Tavola Section Planche Tafel	N. Figura Fig. No. № figure Abb. Nr.	N. Matricola Part. No. Réf. des pièces Bestell-Nr.	Tavola Section Planche Tafel	N. Figura Fig. No. № figure Abb. Nr.
19950052	XV	32	19955015	XVII	16	19961011	VIII	37	19980008	XI	30	19983018	XI	6
19950052	XV	49	19955021	VII	5	19961020	VIII	36	19980009	XI	28	19983021	XI	8
19950052	XV	62	19955037	VII	24	19961022	VII	25	19980010	XI	—	19983022	XI	1
19950053	XV	14	19955038	VII	24	19961026	VIII	35	19980013	XI	33	19983060	XI	5
19950054	XV	78	19955050	VII	4	19961030	VIII	43	19980014	XI	28	19983090	XI	5
19950060	XV	86	19955051	XVII	25	19962006	VIII	50	19980015	XI	30	19983100	XI	3
19950062	XV	79	19955056	XVII	5	19962011	VIII	18	19980016	XI	24	19986010	XV	74
19950063	XV	95	19955056	XVII	34	19962016	VIII	7	19980030	XI	17	19986017	XV	65
19950064	XV	72	19955060	VII	6	19962017	VIII	49	19980030	XI	25	19986220	XVII	26
19950065	VII	39	19955070	XV	23	19962020	VIII	51	19980040	XI	32	19986290	XVII	29
19950069	XV	101	19955081	XV	1	19962022	VIII	3	19980070	XI	17	19987001	VIII	62
19950072	XV	54	19955082	XV	9	19962023	VIII	9	19980070	XI	25	19987004	VIII	54
19950073	XV	47	19955083	XV	7	19962023	VIII	52	19980080	XI	18	19988001	VIII	39
19950083	XV	104	19955088	XV	3	19962026	VIII	2	19980080	XI	24	19988002	VIII	40
19950086	XV	100	19955091	XV	2	19962027	VIII	42	19980090	XI	33	19988010	VIII	27
19950087	XV	60	19955092	XV	5	19962028	VIII	1	19980100	XI	31	19990002	XVII	23
19950088	XV	61	19955093	XVII	14	19962030	VIII	4	19980110	XI	31	19990003	XVII	22
19950089	XV	60	19955094	VII	9	19962040	VIII	51	19980130	XI	31	19990011	XVI	62
19950091	XV	38	19955140	XV	28	19962080	VIII	4	19980140	XI	25	20062002	XII	25
19950092	XV	40	19955150	XV	11	19963002	VIII	19	19981005	XII	2	20062030	XII	24
19950093	XV	39	19955350	XV	4	19963003	VIII	6	19981010	XII	1	20074002	XVI	50
19950094	XV	36	19955360	XV	4	19963004	VIII	12	19981020	XII	45	20251008	II	17
19950094	XV	53	19955370	XV	—	19963005	VIII	5	19981029	XII	5	20251017	II	17
19950095	XV	61	19955380	XV	—	19963006	VIII	20	19981030	XII	21	20251018	II	17
19950101	XV	39	19957005	VII	28	19963008	VIII	19	19981031	XII	4	20251019	II	17
19950103	XV	53	19957030	VII	31	19963009	VIII	12	19981040	XII	33	41016070	VI	101
19950105	XV	38	19957040	VII	34	19970010	VI	47	19981046	XII	56	41018080	VI	111
19950106	XV	40	19958044	VII	15	19970015	VI	46	19981049	XII	47	41031007	IV	29
19950108	XV	98	19958045	VII	16	19970017	VI	45	19981050	XII	27	42010005	I	47
19950112	XV	64	19958100	VII	10	19970018	VI	44	19981070	XII	33	42012024	II	17
19950114	XII	48	19959040	XVI	24	19971004	VI	66	19981400	XII	55	42012025	II	17
19950114	XV	103	19959060	XVI	53	19971030	VI	60	19981420	XII	31	42012026	II	17
19950115	VII	40	19960010	VIII	81	19971050	VI	87	19982005	XI	27	42012027	II	17
19950220	XV	58	19960027	VIII	65	19971070	VI	87	19983001	XI	3	42911002	I	48
19950230	XV	58	19960029	VIII	84	19980002	XI	34	19983002	XI	1	42911003	I	49
19950270	XV	76	19960031	VIII	85	19980003	XI	18	19983003	XI	2	42986023	XVII	30
19950280	XV	77	19960050	VIII	90	19980003	XI	24	19983004	XI	4			
19950290	XV	13	19960060	VIII	89	19980004	XI	33	19983009	XI	4			
19950300	XV	12	19961008	VIII	46	19980005	XI	28	19983010	XI	—			
19955010	XVII	15	19961010	VIII	43	19980006	XI	30	19983016	XI	4			

www.fpw.com

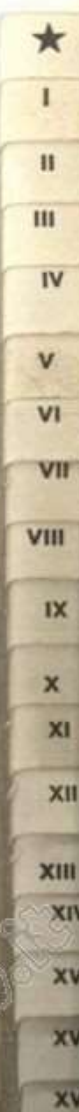

UNIFICATI (UNI) - STANDARD (UNI) - GENORMT (UNI)

N. Matricola Part. No. Réf. des pièces Bestell-Nr.	Tavola Section Planche Tafel	N. Figura Fig. No. № figure Abb. Nr.	N. Matricola Part. No. Réf. des pièces Bestell-Nr.	Tavola Section Planche Tafel	N. Figura Fig. No. № figure Abb. Nr.	N. Matricola Part. No. Réf. des pièces Bestell-Nr.	Tavola Section Planche Tafel	N. Figura Fig. No. № figure Abb. Nr.	N. Matricola Part. No. Réf. des pièces Bestell-Nr.	Tavola Section Planche Tafel	N. Figura Fig. No. № figure Abb. Nr.	N. Matricola Part. No. Réf. des pièces Bestell-Nr.	Tavola Section Planche Tafel	N. Figura Fig. No. № figure Abb. Nr.
65000100	V	13	73020043	XII	19	78920516	X	9	82058009	XV	68	83100004	XIV	28
70300625	VIII	41	73021084	VI	113	80600410	VIII	14	82058009	XV	93	83100005	VIII	11
70300625	XIII	13	73030064	IV	40	81008122	XVII	39	82058009	XVI	64	83100005	XV	8
70300625	XIV	6	73030064	XVI	46	81008127	XII	9	82058009	XVII	18	83100005	XV	16
70300730	IV	3	73060043	XIII	23	81008127	XV	21	82058010	VI	68	83100005	XV	29
70330530	XII	3	73060043	XIV	27	81008127	XV	70	82058010	XI	10	83100005	XV	33
70330630	VIII	70	73150053	XV	22	81008128	XV	97	82058010	XII	22	83100005	XV	63
70360410	XII	20	73150053	XV	69	81008128	XVI	73	82058011	VII	21	83100005	XV	96
70450620	IV	35	73170043	VI	8	81008129	XV	107	82058012	X	24	83100005	XV	106
70850412	XII	37	73170043	XII	18	81008157	VIII	86	82058012	XII	42	83100005	XVII	17
70850516	XVI	61	73170043	XIII	11	81008159	III	30	82058012	XVII	7	83100005	XVII	20
71060618	VI	51	73170053	V	6	81008159	XVI	30	82058012	XVII	11	83100006	I	23
71061035	VIII	44	73170053	V	8	81008160	IV	9	82058012	XVII	36	83100006	I	41
71160420	VI	95	73170074	I	17	81008160	XVI	35	82058012	XVII	42	83100006	IV	10
71160425	VI	98	73170084	VII	37	81008192	VII	20	82078012	VI	112	83100006	IV	36
71180425	XIII	12	73250016	II	16	81008219	V	12	82108009	XV	10	83100006	V	4
71300414	XV	105	73250018	IV	7	81008221	VII	35	82108009	XV	25	83100006	VI	69
71300512	XV	6	73250032	IX	54	81008222	VI	115	82108009	XV	27	83100006	VIII	47
71300520	XV	84	73250032	X	35	81008222	XVII	8	82108009	XVII	19	83100006	XI	9
71300522	XV	6	73250042	IV	24	81008224	XVII	33	82108010	VIII	73	83100006	XI	11
71300522	XVII	21	73250052	II	14	81008244	XVII	4	82108011	I	16	83100006	XI	23
71300616	II	4	73260005	IV	41	81428378	VI	110	82108012	VII	36	83100006	XII	23
71420410	XV	56	73260006	IV	39	82008010	I	22	82108012	VII	36	83100006	XIII	14
71420416	XV	73	73260010	III	1	82008010	I	40	82118014	XVI	45	83100006	XIV	5
71420516	XV	88	73260010	III	14	82008010	V	3	82118015	VIII	91	83100006	XV	82
71420520	XV	48	73260010	IX	9	82008012	I	38	82118015	IX	19	83100006	XVI	31
71420520	XV	90	73260010	IX	18	82008012	I	50	82118015	IX	58	83100006	XVI	36
71450425	XV	35	73260010	XIV	10	82058007	XII	17	82118015	X	40	83100007	IV	4
71450428	XV	56	73260012	III	4	82058007	XII	53	82250060	VIII	67	83100007	VI	75
71450545	VIII	30	73260012	III	12	82058007	XIII	25	83010012	XVI	49	83100007	VI	108
71480412	XI	35	73260012	IX	24	82058007	XIV	29	83010641	VI	53	83100007	VII	22
71480418	XV	59	73260012	IX	48	82058007	XV	43	83020605	VIII	72	83100007	XVI	21
71480612	VIII	8	73260012	XVI	48	82058007	XV	83	83050616	VI	52	83100008	I	39
71490322	XII	28	73260020	IV	5	82058009	XII	7	83070820	VI	114	83100008	I	52
71490322	XII	32	74400228	VI	64	82058009	XV	17	83100004	VIII	15	83100008	I	57
71670812	VII	26	74400228	XVI	47	82058009	XV	20	83100004	XII	38	83100008	V	11
72070016	VII	17	74850465	II	15	82058009	XV	30	83100004	XII	54	83100008	IX	39
73010064	XV	102	75710308	VII	8	82058009	XV	34	83100004	XIII	20	83100008	IX	64
73010084	XII	51	78920516	IV	31	82058009	XV	52	83100004	XIII	24	83100008	X	46
									83100004	XIV	24	83100008	X	48

www.flyonline.it

UNIFICATI (UNI) - STANDARD (UNI) - GENORMT (UNI)

N. Matricola Part. No. Réf. des pièces Bestell-Nr.	Tavola Section Planche Tafel	N. Figura Fig. No. N° figure Abb. Nr.	N. Matricola Part. No. Réf. des pièces Bestell-Nr.	Tavola Section Planche Tafel	N. Figura Fig. No. N° figure Abb. Nr.	N. Matricola Part. No. Réf. des pièces Bestell-Nr.	Tavola Section Planche Tafel	N. Figura Fig. No. N° figure Abb. Nr.	N. Matricola Part. No. Réf. des pièces Bestell-Nr.	Tavola Section Planche Tafel	N. Figura Fig. No. N° figure Abb. Nr.	N. Matricola Part. No. Réf. des pièces Bestell-Nr.	Tavola Section Planche Tafel	N. Figura Fig. No. N° figure Abb. Nr.
83100008	XII	43	83110004	XIII	7	83120006	VIII	68	86011622	I	32	87200008	XII	26
83100008	XVII	6	83110004	XIV	3	83120006	VIII	74	86011622	I	35	87310001	XII	14
83100008	XVII	10	83110004	XIV	11	83120006	VIII	87	86011622	I	37	87310005	XII	14
83100008	XVII	35	83110004	XIV	13	83120010	VIII	45	86500300	XVI	60	87520300	VIII	63
83100008	XVII	41	83110005	XII	8	83120012	VIII	92	87020006	I	18	87550500	XI	26
83100010	IV	2	83110005	XVI	63	83120016	VI	83	87020006	VIII	88	87570315	XI	12
83100010	XVI	44	83110006	XII	46	83130005	VIII	29	87020006	IX	12	87652525	XI	29
83100016	I	56	83120003	VIII	53	85701035	XVI	76	87020006	IX	22			
83100016	VII	18	83120005	XVI	74	85800216	I	34	87020006	X	13			

www.fpw.it



TAVOLA RAPPORTI CAMBIO - SECTION OF GEARBOX RATIOS - PLANCHE RAPPORTS DE BOITE DE VITESSES - TAFEL WECHSELGETRIEBE-ÜBERSETZUNGEN

Modello Model Modèle Modell	Albero primario Main shaft Arbre primaire Getriebewelle	N. denti No. teeth N° dents Nr. Zähne	Ingranaggio I velocità 1st. Speed gear Pignon 1ère vitesse Zahnrad 1. Gang	N. denti No. teeth N° dents Nr. Zähne	Ingranaggio II velocità 2nd. Speed gear Pignon 2ème vitesse Zahnrad 2. Gang	N. denti No. teeth N° dents Nr. Zähne	Ingranaggio III velocità 3rd. Speed gear Pignon 3ème vitesse Zahnrad 3. Gang	N. denti No. teeth N° dents Nr. Zähne	Ingranaggio IV velocità 4th. Speed gear Pignon 4ème vitesse Zahnrad 4. Gang	N. denti No. teeth N° dents Nr. Zähne
LAMBRETTA LI/125 - 3ª Serie †	19130013	9 12 16 19	19130014	51	19130015	42	19130016	39	19130017	35
LAMBRETTA LI/125 - 3ª Serie ❖	19830001	11 13 17 19	19030003	50	19830009	41	19830005	39	19130017	35
LAMBRETTA 125 SPECIAL	19430007	10 12 15 18	19430008	50	19430009	42	19430011	39	19430012	36
LAMBRETTA LI/150 - 3ª Serie	19030001	11 14 17 20	19030003	50	19030004	41	19030005	37	19030006	34
LAMBRETTA 150 SPECIAL	19830001	11 13 17 19	19030003	50	19830009	41	19830005	39	19130017	35
LAMBRETTA 150 SX	19530501	10 12 15 19	19430008	50	19430009	42	19430011	39	19130017	35
LAMBRETTA 175/TV.	19230001	12 14 18 21	19230003	49	19230004	40	19230005	37	19230006	33
LAMBRETTA 200 SX	19230001	12 14 18 21	19230003	49	19230004	40	19230005	37	19230006	33

† Pre-modifica. Pre-modification. Pré-modification. Vor-Aenderung.

❖ Post-modifica. Post-modification. Post-modification. Nach-Aenderung.

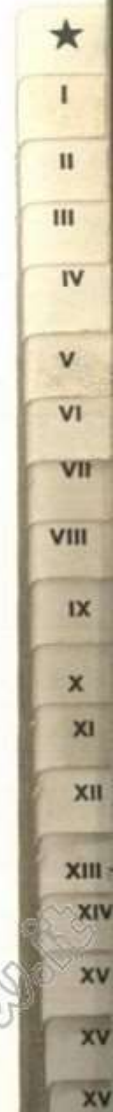
REGOLAZIONE CARBURATORI - CARBURETTOR ADJUSTMENT - REGLAGE CARBURATEURS - VERGASEREINSTELLUNG

Modello Model Modèle Modell	PARTICOLARI TARATI				CALIBRATED PARTS				PIECES CALIBREES				KALIBRIERTE TEILE			
	Carburatori Carburettors Carburateurs Vergaser		Valvola gas Throttle slide Boisseau de gas Gasschieber		Emulsionatore Diffuser Diffuseur Diffusor		Getto max. Main Jet Gicleur principal Hauptdüse		Getto minimo Pilot Jet Gicleur du ralenti Leerlaufdüse		Getto starter Starter Jet Gicleur starter Starterdüse					
	DELLORTO	INNOCENTI	DELLORTO	INNOCENTI	DELLORTO	INNOCENTI	DELLORTO	INNOCENTI	DELLORTO	INNOCENTI	DELLORTO	INNOCENTI				
LAMBRETТА LI/125 - 3ª Serie	SH1/18	00412441	5914-01-64	00412396	5899-01-28	00412339	1486-99-02	00412348	3360-42-02	00412346	5907-50-02	00412398				
LAMBRETТА LI/150 - 3ª Serie	SH1/18	00412441	5914-02-64	00412437	5899-01-28	00412339	1486-105-02	00412256	3360-45-02	00412404	5907-50-02	00412398				
LAMBRETТА 150 SPECIAL	SH1/18	00412441	5914-01-64	00412396	5899-02-28	00412402	1486-101-02	00412358	3360-45-02	00412404	5907-50-02	00412398				
LAMBRETТА 125 SPECIAL ✦	SH1/20	00412442	5914-02-64	00412437	5899-04-28	00412444	1486-107-02	00412408	3360-45-02	00412404	5907-50-02	00412398				
LAMBRETТА 125 SPECIAL ✧	SH1/20	00412442	5914-02-64	00412437	5899-05-28	04012436	1486-98-02	00412435	3360-45-02	00412404	5907-50-02	00412398				
LAMBRETТА 150 SX	SH1/20	00412442	5914-02-64	00412437	5899-05-28	04012436	1486-102-02	00412440	3360-45-02	00412404	5907-50-02	00412398				
LAMBRETТА 175/TV.	SH1/20	00412443	5914-01-64	00412396	5899-02-28	00412402	1486-106-02	00412347	3360-50-02	00412351	5907-50-02	00412398				
LAMBRETТА 200 SX	SH1/20	00412443	5914-01-64	00412396	5899-02-28	00412402	1486-103-02	00412407	3360-48-02	00412353	5907-50-02	00412398				

I carburatori sono forniti con i particolari tarati necessari alla regolazione secondo il tipo di Lambretta, in base alla tavola «Regolazione carburatori».
 The carburetors are supplied with the calibrated parts which must be used according to the adjustment each Lambretta model requires, consulting the «Carburettor adjustment» table.
 Les carburateurs sont fournis avec les pièces calibrées qui sont à employer selon le réglage que chaque modèle de Lambretta demande, en consultant la table «Réglage carburateurs».
 Die Vergaser werden mit den kalibrierten Teilen geliefert, die je nach dem Lambretta Modell für die Einstellung erforderlich sind. Man konsultiere hierzu die «Vergasereinstellung» Tafel.

✦ Pre-modifica. Pre-modification. Pré-modification. Vor-Aenderung.

✧ Post-modifica. Post-modification. Post-modification. Nach-Aenderung.

www.zipw.com

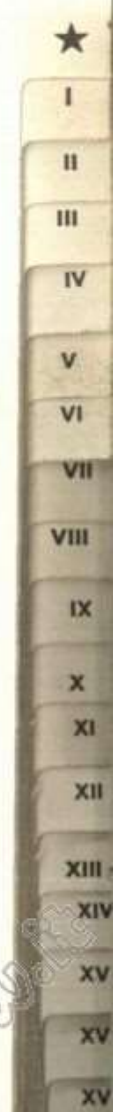

Carter motore - cilindro

Crankcase - cylinder

Carter moteur - cylindre

Motorgehäuse - Zylinder

Tav. I

Fig. Abb.	Ord. No. Bestell N.	Denominazione	Description	Désignation	Benennung	Qt. Anzahl	125 LI	125 S	150 LI	150 S	150 SX	175 TV	200 SX
1	19010160 *	Carter motore	Crankcase	Carter moteur	Motorgehäuse	1	o		o				
	19610160 *	Carter motore	Crankcase	Carter moteur	Motorgehäuse	1							o
	19710160 *	Carter motore	Crankcase	Carter moteur	Motorgehäuse	1		o		o	o	o	
2	19010011	Perno	Shaft	Axe	Bolzen	1	o	o	o	o	o	o	o
3	19030039	Bussola	Bush	Bague	Büchse	1	o	o	o	o	o	o	o
4	19030038	Rondella di spallamento	Shim	Rondelle de réglage	Ausgleichscheibe	1	o	o	o	o	o	o	o
5	19010044	Bussola	Bush	Bague	Büchse	1	o	o	o	o	o	o	o
6	19010026	Prigioniero	Stud	Goujon	Stiftschraube	4	o	o	o	o	o	o	o
7	19010022	Prigioniero	Stud	Goujon	Stiftschraube	6	o	o	o	o	o	o	o
8	19010019	Prigioniero	Stud	Goujon	Stiftschraube	14	o	o	o	o	o	o	o
9	19010030	Silentbloc	Silentblock	Silentbloc	Silentblock	2	o		o				
	19710030	Silentbloc	Silentblock	Silentbloc	Silentblock	2		o		o	o	o	o
10	19010053	Prigioniero	Stud	Goujon	Stiftschraube	2	o	o	o	o	o	o	o
11	19210013	Prigioniero	Stud	Goujon	Stiftschraube	4	o	o	o	o	o	o	o
	19210014	Prigioniero maggiorato	Stud, oversized	Goujon majoré	Übermasste Stiftschraube	—	o	o	o	o	o	o	o
12	19010009	Prigioniero	Stud	Goujon	Stiftschraube	3	o	o	o	o	o	o	o
13	19010050 †	Flangia con fig. 14	Flange, with fig. 14	Bride avec fig. 14	Flansch mit Abb. 14	1	o	o	o	o	o	o	o
	19510060 ‡	Flangia con fig. 14	Flange with fig. 14	Bride avec fig. 14	Flansch mit Abb. 14	1	o	o	o	o	o	o	o
14	19010006	Bussola	Bush	Bague	Büchse	1	o	o	o	o	o	o	o
15	19010008	Spina	Pin	Axe	Passtift	2	o	o	o	o	o	o	o
16	82108011	Dado	Nut	Ecrou	Mutter	6	o	o	o	o	o	o	o
17	73170074	Rondella elastica	Spring washer	Rondelle élastique	Federscheibe	6	o	o	o	o	o	o	o
18	87020006	Ingrassatore	Greaser nipple	Graisneur	Schmiernippel	1	o	o	o	o	o	o	o
19	19030040	Gabbia a rullini	Needle cage	Cage à aiguilles	Nadelkäfig	1	o	o	o	o	o	o	o
20	19030021	Flangia	Flange	Bride	Halteflansch	1	o	o	o	o	o	o	o
21	19030035	Rondella	Washer	Rondelle	Scheibe	1	o	o	o	o	o	o	o
22	82008010	Dado	Nut	Ecrou	Mutter	4	o	o	o	o	o	o	o
23	83100006	Rondella elastica	Spring washer	Rondelle élastique	Federscheibe	4	o	o	o	o	o	o	o
24	19010027	Perno	Pin	Axe	Bolzen	2	o	o	o	o	o	o	o
25	19010036	Tampone	Rebound buffer	Tampon amortisseur	Gummipuffer	1	o	o	o	o	o	o	o

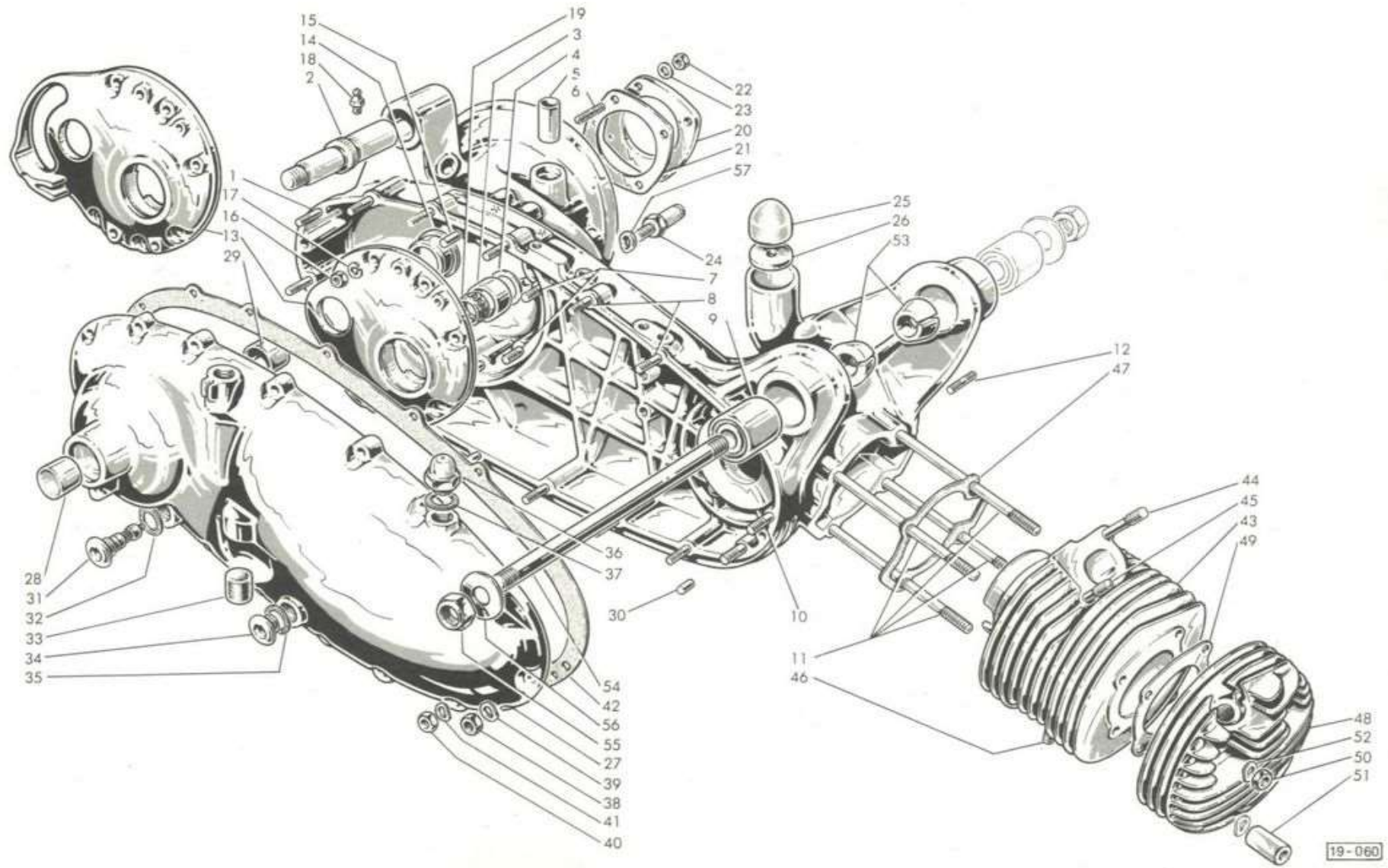

I
II
III
IV
V
VI
VII
VIII
IX
X
XI
XII
XIII
XIV
XV
XVI
XVII



www.rpww.com

Fig. Abb.	Ord. No. Bestell N.	Denominazione	Description	Désignation	Benennung	Qt. Anzahl	125 LI	125 S	150 LI	150 S	150 SX	175 TV	200 SX
26	19010035	Rondella	Washer	Rondelle	Scheibe	1	o	o	o	o	o	o	o
27	19910020	Coperchio con figg. 28-29	Cover with fig. 28-29	Couvercle avec fig. 28-29	Deckel mit Abb. 28-29	1	o	o	o	o	o	o	o
28	19030026	Bussola	Bush	Bague	Büchse	1	o	o	o	o	o	o	o
29	19030025	Bussola	Bush	Bague	Büchse	1	o	o	o	o	o	o	o
30	19010008	Spina	Pin	Axe	Passstift	2	o	o	o	o	o	o	o
31	19010130	Tappo	Plug	Bouchon	Ölablass-Schraube	1	o	o	o	o	o	o	o
32	86011622	Guarnizione	Gasket	Joint	Dichtung	1	o	o	o	o	o	o	o
33	15041024	Tampone	Buffer	Tampon	Gummipuffer	1	o	o	o	o	o	o	o
34	85800216	Tappo	Plug	Bouchon	Ölstand-Schraube	1	o	o	o	o	o	o	o
35	86011622	Guarnizione	Gasket	Joint	Dichtung	1	o	o	o	o	o	o	o
36	15010090	Sfiatatoio	Breather	Reniflard	Entlüfter	1	o	o	o	o	o	o	o
37	86011622	Guarnizione	Gasket	Joint	Dichtung	1	o	o	o	o	o	o	o
38	82008012	Dado	Nut	Ecrou	Mutter	2	o	o	o	o	o	o	o
39	83100008	Rondella elastica	Spring washer	Rondelle élastique	Federscheibe	2	o	o	o	o	o	o	o
40	82008010	Dado	Nut	Ecrou	Mutter	14	o	o	o	o	o	o	o
41	83100006	Rondella elastica	Spring washer	Rondelle élastique	Federscheibe	14	o	o	o	o	o	o	o
42	19010056	Guarnizione	Gasket	Joint	Dichtung	1	o	o	o	o	o	o	o
43	19011020	Cilindro	Cylinder	Cylindre	Zylinder	1			o				
	19911050	■ Gruppo cilindro	Cylinder assy	Ensemble cylindre	Zylindergruppe	1			o				
	19411020	Cilindro	Cylinder	Cylindre	Zylinder	1	o	o					
	19411030	■ Gruppo cilindro	Cylinder assy	Ensemble cylindre	Zylindergruppe	1	o	o					
	19511020	Cilindro	Cylinder	Cylindre	Zylinder	1				o			
	19511050	■ Gruppo cilindro	Cylinder assy	Ensemble cylindre	Zylindergruppe	1				o			
	19511510	Cilindro	Cylinder	Cylindre	Zylinder	1					o		
	19511520	■ Gruppo cilindro	Cylinder assy	Ensemble cylindre	Zylindergruppe	1					o		
	19611020	Cilindro	Cylinder	Cylindre	Zylinder	1						o	
	19611050	■ Gruppo cilindro	Cylinder assy	Ensemble cylindre	Zylindergruppe	1						o	
	19711020	Cilindro	Cylinder	Cylindre	Zylinder	1							o
44	19711030	■ Gruppo cilindro	Cylinder assy	Ensemble cylindre	Zylindergruppe	1							o
	19011012	Prigioniero (lungo)	Stud (long)	Goujon (long)	Stiftschraube (lang)	1	o	o	o			o	
	19611012	Prigioniero (lungo)	Stud (long)	Goujon (long)	Stiftschraube (lang)	1							o

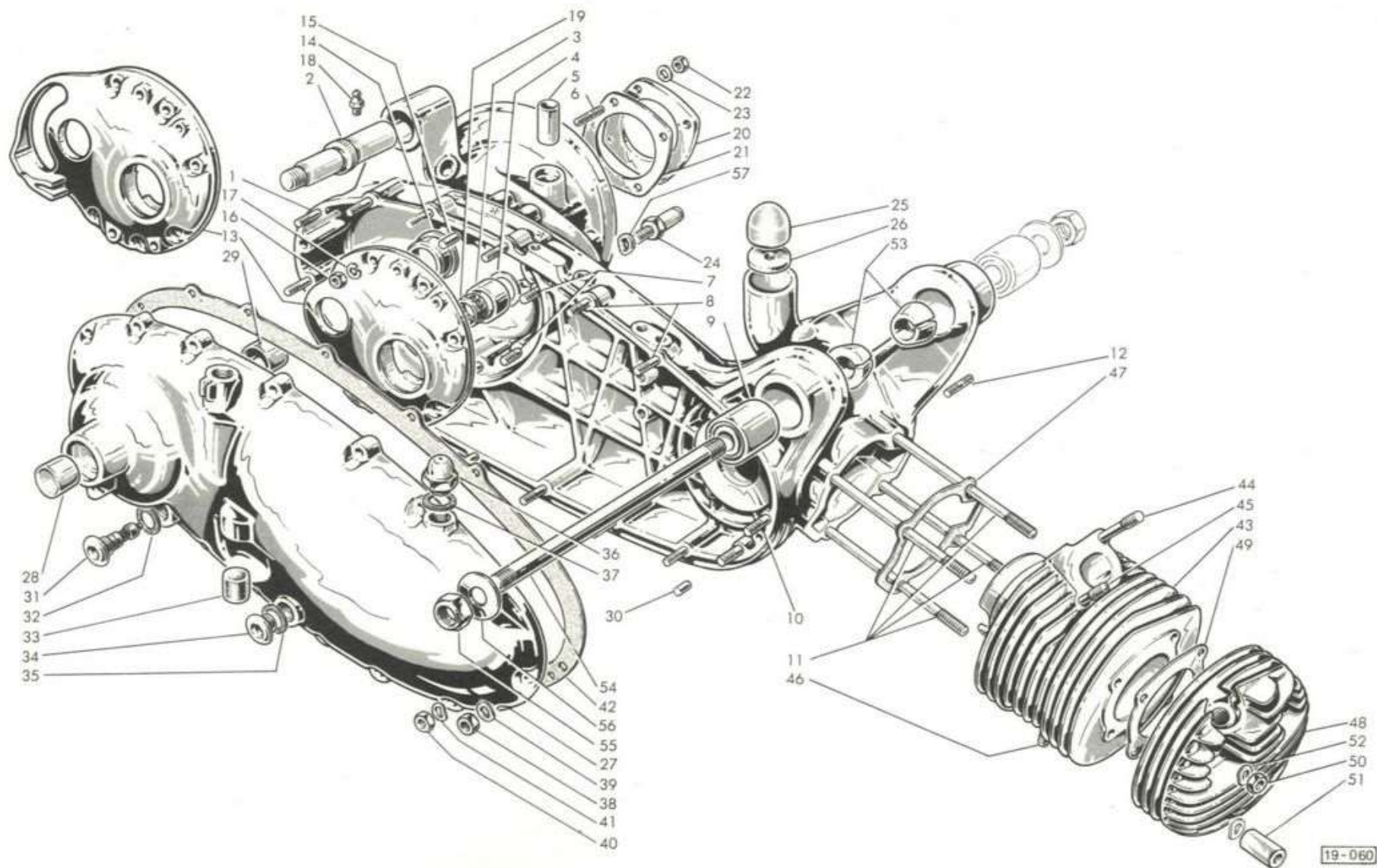

19-060



www.rpww.com

II
III
IV
V
VI
VII
VIII
IX
X
XI
XII
XIII
XIV
XV
XV
XV

Fig. Abb.	Ord. No. Bestell N.	Denominazione	Description	Désignation	Benennung	Qt. Anzahl	125 LI	125 S	150 LI	150 S	150 SX	175 TV	200 SX
45	19011013	Prigioniero (corto)	Stud (short)	Goujon (court)	Stiftschraube (kurz)	1	o	o	o	o	o	o	o
46	19011008	Prigioniero	Stud	Goujon	Stiftschraube	2	o	o	o	o	o	o	o
47	19010012	Guarnizione	Gasket	Joint	Dichtung	1	o	o	o	o	o	o	
	42010005	Guarnizione	Gasket	Joint	Dichtung	1							o
48	19111015	Testina	Head, cylinder	Culasse	Zylinderkopf	1	o						
	19411015	Testina	Head, cylinder	Culasse	Zylinderkopf	1		o					
	19711015	Testina	Head, cylinder	Culasse	Zylinderkopf	1						o	
	19911015	Testina	Head, cylinder	Culasse	Zylinderkopf	1			o	o	o		
	42911002	Testina	Head, cylinder	Culasse	Zylinderkopf	1							o
49	19011003	Guarnizione	Gasket	Joint	Dichtung	1			o	o			
	19011003	Guarnizione	Gasket	Joint	Dichtung	2					o		
	19111003	Guarnizione	Gasket	Joint	Dichtung	1	o	o					
	19211003	Guarnizione	Gasket	Joint	Dichtung	1						o	
	42911003	Guarnizione	Gasket	Joint	Dichtung	1							o
50	82008012	Dado	Nut	Ecrou	Mutter	3	o	o	o	o	o	o	o
51	19010007	Colonna	Distance nut	Ecrou d'entretoise	Spezialmutter	1	o	o	o	o	o	o	o
52	83100008	Rondella elastica	Spring washer	Rondelle élastique	Federscheibe	4	o	o	o	o	o	o	o
53	19010028	Cono	Cone	Cône	Kegelmuffe	2	o		o				
	19710028	Cono	Cone	Cône	Kegelmuffe	2		o		o	o	o	o
54	19010029	Perno	Spindle	Pivot	Lagerbolzen	1	o		o				
	19710029	Perno	Spindle	Pivot	Lagerbolzen	1		o		o	o	o	o
55	19010120	Dado	Nut	Ecrou	Mutter	2	o	o	o	o	o	o	o
56	83100016	Rondella	Washer	Rondelle	Scheibe	2	o	o	o	o	o	o	o
57	83100008	Rondella per fig. 24	Washer for fig. 24	Rondelle pour fig. 24	Scheibe für Abb. 24	2	o	o	o	o	o	o	o

✦ { Pre-modifica.
Pre-modification.
Pré-modification.
Vor-Aenderung.

✧ { Post-modifica.
Post-modification.
Post-modification.
Nach-Aenderung.

★ { Il Carter Motore è composto dalle Figg. } 2 - 3 - 4 - 5 - 6 - 7 -
The Crankcase consists of Fig. } 8 - 9 - 10 - 11 - 12.
Le Carter Moteur consiste des Fig. }
Das Motorgehäuse besteht aus den Abb. }

■ { Il Gruppo Cilindro è composto da: Cilindro, Pistone, Segmento, Spinotto, Rondella e Anello elastico.
The Cylinder Assy consists of: Cylinder, Piston, Piston Ring, Gudgeon Pin, Washer and Circlip.

■ { L'ensemble Cylindre consiste de: Cylindre, Piston, Segment, Axe, Rondelle et Circlip.
Die Zylindergruppe besteht aus: Zylinder, Kolben, Kolbenring, Kolbenbolzen,
Scheibe und Seegerring.

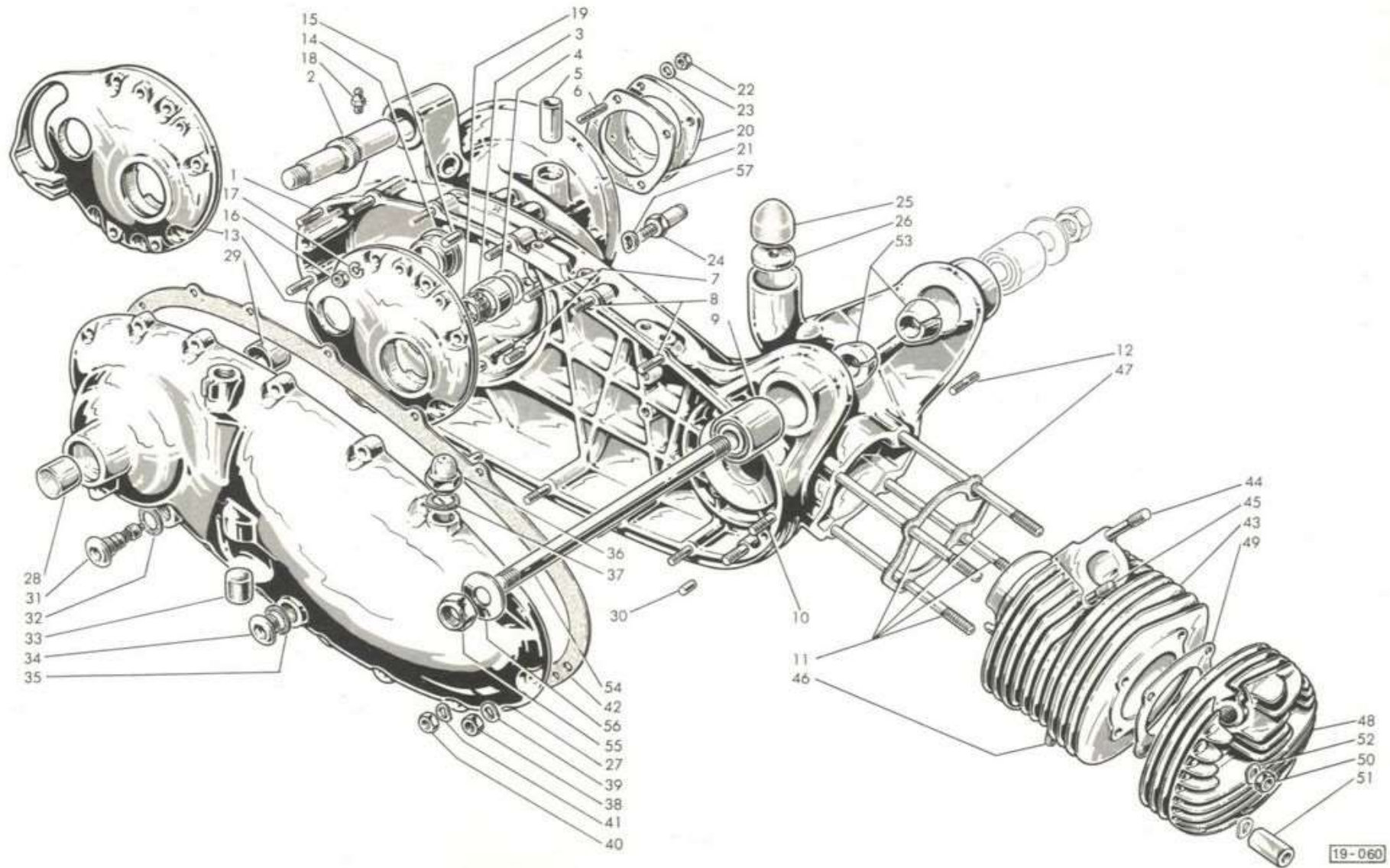

www.rpww.com

II
III
IV
V
VI
VII
VIII
IX
X
XI
XII
XIII
XIV
XV
XV
XV

Fig. Abb.	Ord. No. Bestell N.	Denominazione	Description	Désignation	Benennung	Qt. Anzahl	125 LI	125 S	150 LI	150 S	150 SX	175 TV	200 SX
1	19212140	Albero motore	Crankshaft	Vilebrequin	Kurbelwelle	1						o	
	19612150	Albero motore	Crankshaft	Vilebrequin	Kurbelwelle	1							o
	19912190	Albero motore	Crankshaft	Vilebrequin	Kurbelwelle	1	o	o	o	o	o		
2	19012130	Gabbia a rullini	Needle cage	Cage à aiguilles	Nadelkäfig	1	o	o	o	o	o	o	o
3	19012008	Anello di tenuta (33 x 50 x 6)	Oil seal	Anneau d'étanchéité	Dichtring	1	o	o	o	o	o	o	o
4	71300616	Vite	Screw	Vis	Schraube	4	o	o	o	o	o	o	o
5	19012006	Flangia	Flange	Bride	Flansch	1	o	o	o	o	o	o	o
6	19012007	Rondella	Washer	Rondelle	Scheibe	1	o	o	o	o	o	o	o
7	19012031	Cuscinetto	Ball bearing	Roulement	Kugellager	1	o	o	o	o	o	o	o
8	19012041	Rondella	Washer	Rondelle	Scheibe	1	o	o	o	o	o	o	o
9	19012039	Anello di tenuta (25 x 42 x 6)	Oil seal	Anneau d'étanchéité	Dichtring	1	o	o	o	o	o	o	o
10	19012038	Scodellino	Retainer	Cuvette	Dichtungsgehäuse	1	o	o	o	o	o	o	o
11	19012034	Cuscinetto	Ball bearing	Roulement	Kugellager	1	o	o	o	o	o	o	o
12	19012037	Distanziale	Distance piece	Entretoise	Distanzstück	1	o	o	o	o	o	o	o
13	19012036	Anello di tenuta (33 x 52 x 6)	Oil seal	Anneau d'étanchéité	Dichtring	1	o	o	o	o	o	o	o
14	73250052	Anello elastico	Circlip	Circlip	Seegerring	1	o	o	o	o	o	o	o
15	74850465	Chiavetta	Woodruff key	Clavette	Scheibenfeder	1	o	o	o	o	o	o	o
16	73250016	Anello elastico	Circlip	Circlip	Seegerring	2	o	o	o	o	o	o	o
17	19412045	Segmento Ø 52	Piston ring	Segment	Kolbenring	2	o	o					
	19412046	Segmento Ø 52,2	Piston ring	Segment	Kolbenring	—	o	o					
	19412047	Segmento Ø 52,4	Piston ring	Segment	Kolbenring	—	o	o					
	19412048	Segmento Ø 52,6	Piston ring	Segment	Kolbenring	—	o	o					
	19712024	Segmento Ø 62	Piston ring	Segment	Kolbenring	3						o	
	19712025	Segmento Ø 62,2	Piston ring	Segment	Kolbenring	—						o	
	19712026	Segmento Ø 62,4	Piston ring	Segment	Kolbenring	—						o	
	19712027	Segmento Ø 62,6	Piston ring	Segment	Kolbenring	—						o	
	20251008	Segmento Ø 57	Piston ring	Segment	Kolbenring	2			o	o	o		
	20251017	Segmento Ø 57,2	Piston ring	Segment	Kolbenring	—			o	o	o		
20251018	Segmento Ø 57,4	Piston ring	Piston ring	Segment	—			o	o	o			
20251019	Segmento Ø 57,6	Piston ring	Piston ring	Segment	—			o	o	o			

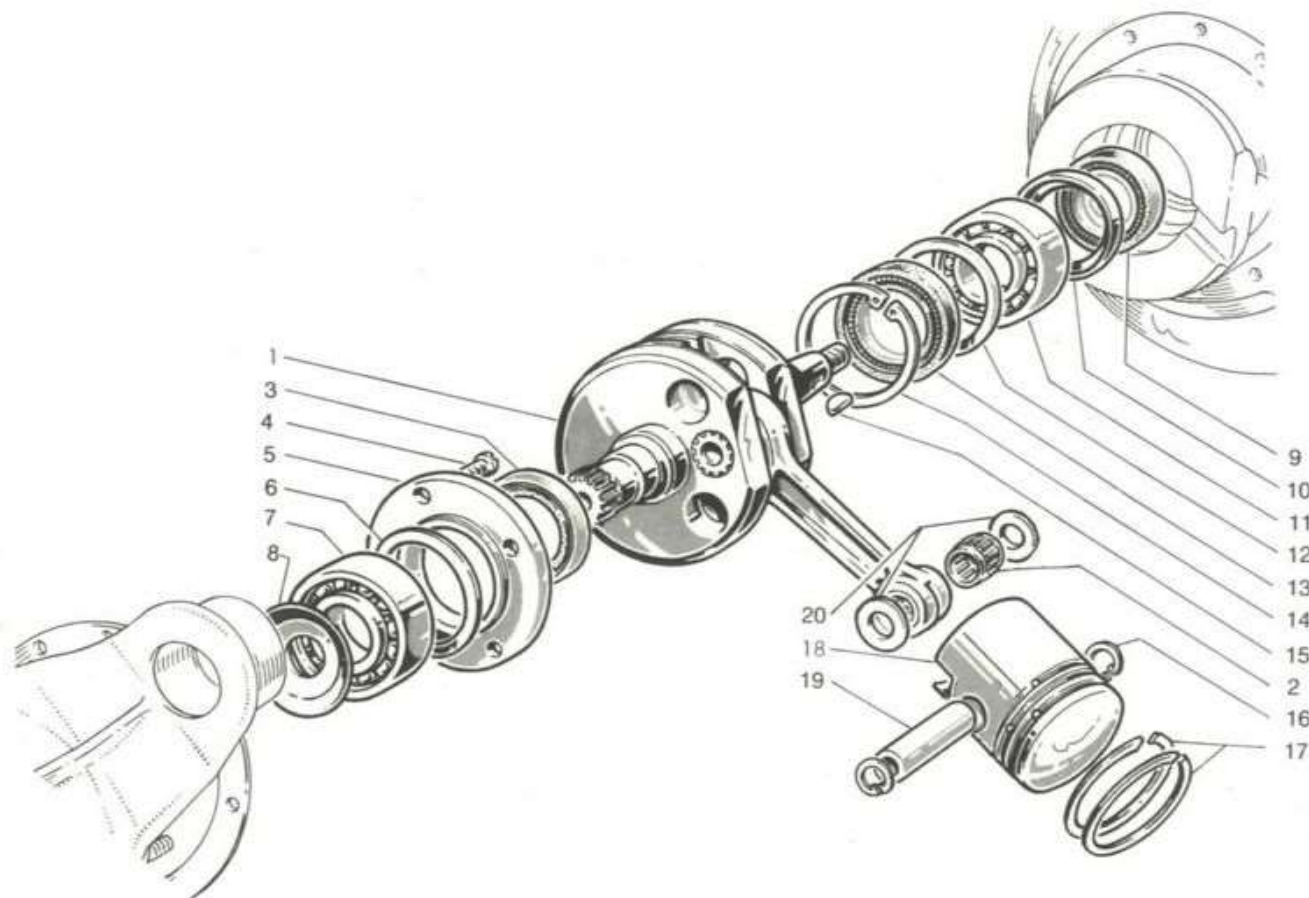

19 - 061



www.zp...

II
III
IV
V
VI
VII
VIII
IX
X
XI
XII
XIII
XIV
XV
XV
XV

Fig. Abb.	Ord. No. Bestell N.	Denominazione	Description	Désignation	Benennung	Qt. Anzahl	125 LI	125 S	150 LI	150 S	150 SX	175 TV	200 SX
17	42012024	Segmento Ø 66	Piston ring	Segment	Kolbenring	3							o
	42012025	Segmento Ø 66,2	Piston ring	Segment	Kolbenring	—							o
	42012026	Segmento Ø 66,4	Piston ring	Segment	Kolbenring	—							o
	42012027	Segmento Ø 66,6	Piston ring	Segment	Kolbenring	—							o
18	19412150	Pistone Ø 52	Piston	Piston	Kolben	1	o	o					
	19412160	Pistone Ø 52,2	Piston	Piston	Kolben	—	o	o					
	19412170	Pistone Ø 52,4	Piston	Piston	Kolben	—	o	o					
	19412180	Pistone Ø 52,6	Piston	Piston	Kolben	—	o	o					
	19612270	Pistone Ø 66	Piston	Piston	Kolben	1							o
	19612280	Pistone Ø 66,2	Piston	Piston	Kolben	—							o
	19612290	Pistone Ø 66,4	Piston	Piston	Kolben	—							o
	19612300	Pistone Ø 66,6	Piston	Piston	Kolben	—							o
	19712090	Pistone Ø 62	Piston	Piston	Kolben	1						o	
	19712100	Pistone Ø 62,2	Piston	Piston	Kolben	—						o	
	19712110	Pistone Ø 62,4	Piston	Piston	Kolben	—						o	
	19712120	Pistone Ø 62,6	Piston	Piston	Kolben	—						o	
	19912200	Pistone Ø 57	Piston	Piston	Kolben	1			o	o	o		
	19912210	Pistone Ø 57,2	Piston	Piston	Kolben	—			o	o	o		
	19912220	Pistone Ø 57,4	Piston	Piston	Kolben	—			o	o	o		
	19912230	Pistone Ø 57,6	Piston	Piston	Kolben	—			o	o	o		
19	19012018	Spinotto	Gudgeon pin	Axe de piston	Kolbenbolzen	1			o	o	o		
	19112018	Spinotto	Gudgeon pin	Axe de piston	Kolbenbolzen	1	o	o					
	19212018	Spinotto	Gudgeon pin	Axe de piston	Kolbenbolzen	1						o	
	19612018	Spinotto	Gudgeon pin	Axe de piston	Kolbenbolzen	1						o	
20	19912011	Rondella	Washer	Rondelle	Scheibe	2	o	o	o	o	o		o

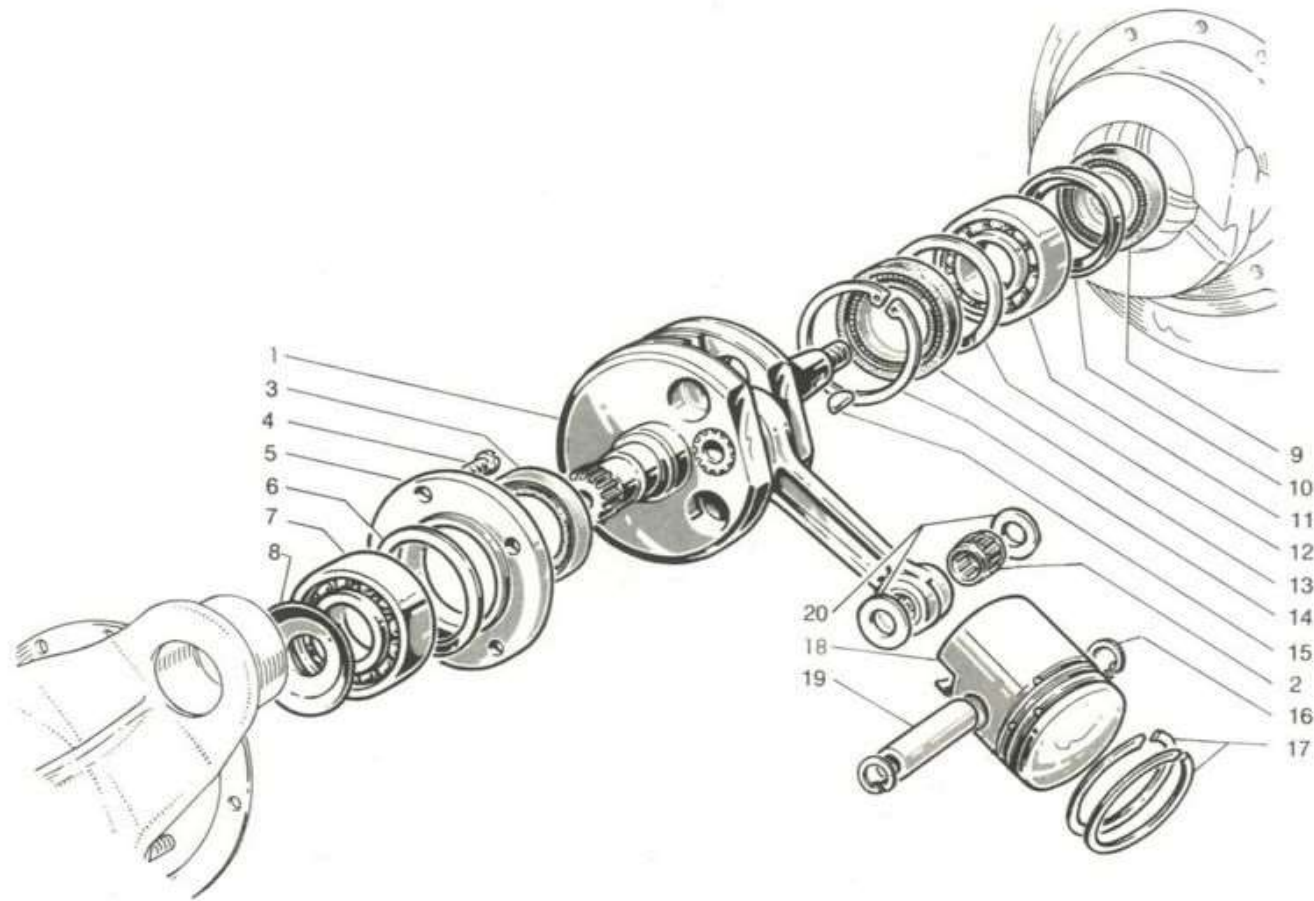

19 - 061



www.rpww.com

III
IV
V
VI
VII
VIII
IX
X
XI
XII
XIII
XIV
XV
XV
XV

Fig. Abb.	Ord. No. Bestell N.	Denominazione	Description	Désignation	Benennung	Qt. Anzahl	125 LI	125 S	150 LI	150 S	150 SX	175 TV	200 SX
1	73260010	Anello elastico	Circlip	Circlip	Seegerring	1	o	o	o	o	o	o	o
2	19021006	Leva	Lever	Levier	Hebel	1	o	o	o	o	o	o	o
3	19021007	Molla	Spring	Ressort	Feder	1	o	o	o	o	o	o	o
4	73260012	Anello elastico	Circlip	Circlip	Seegerring	1	o	o	o	o	o	o	o
5	19031015	Rondella	Washer	Rondelle	Scheibe	1	o	o	o	o	o	o	o
6	19021004	Alberino	Shaft	Arbre	Kupplungsspindel	1	o	o	o	o	o	o	o
7	19031013	Anello di tenuta	Oil seal	Anneau d'étanchéité	Dichtring	1	o	o	o	o	o	o	o
8	19020018	Disco condotto	Driven disc	Disque conduite	Getriebene Scheibe	1	o	o	o	o	o	o	o
9	19021001	Puntalino	Push rod	Poussoir	Stößel	1	o	o	o	o	o	o	o
10	19020016	Anello elastico	Circlip	Circlip	Seegerring	1	o	o	o	o	o	o	o
11	19031015	Rondella	Washer	Rondelle	Scheibe	1	o	o	o	o	o	o	o
12	73260012	Anello elastico	Circlip	Circlip	Seegerring	1	o	o	o	o	o	o	o
13	19021002	Levetta	Lever	Levier	Nocken	1	o	o	o	o	o	o	o
14	73260010	Anello elastico	Circlip	Circlip	Seegerring	1	o	o	o	o	o	o	o
15	19920120	Flangia	Flange	Bride	Flansch	1	o	o	o	o	o	o	o
16	19020050	Disco conduttore	Driving disc	Disque conducteur	Antriebsscheibe	4	o	o	o	o	o	o	o
17	19020021	Disco condotto	Driven disc	Disque conduite	Getriebene Scheibe	3	o	o	o	o	o	o	o
18	19920036	Corona	Crown wheel	Couronne	Zahnrad	1	o	o	o	o	o	o	o
19	19020080	Campana	Clutch housing	Boîte d'embrayage	Kupplungsgehäuse	1	o	o	o	o	o	o	o
20	19030045	Piastrina	Thrust plate	Plaquette	Sicherungsblech	1	o	o	o	o	o	o	o
21	19020015	Molla	Spring	Ressort	Feder	5	o	o	o	o	o		
	19220015	Molla	Spring	Ressort	Feder	5						o	o
22	19030007	Dado	Nut	Ecrou	Mutter	1	o	o	o	o	o	o	o
23	19020070	Gabbia a rullini	Needle cage	Cage à aiguilles	Nadelkäfig	2	o	o	o	o	o	o	o
24	19041090 *	Catena	Chain	Chaîne	Kette	1	o	o	o	o	o	o	o
	19041130	Catena	Chain	Chaîne	Kette	1	o	o	o	o	o	o	o
25	19012017	Innesto scorrevole	Sliding dog	Embrayage à glissement	Mitnehmer	1	o	o	o	o	o	o	o
26	19012042	Molla	Spring	Ressort	Feder	1	o	o	o	o	o	o	o
27	19012043	Rondella	Washer	Rondelle	Scheibe	1	o	o	o	o	o	o	o
28	19012013	Vite	Screw	Vis	Schraube	1	o	o	o	o	o	o	o

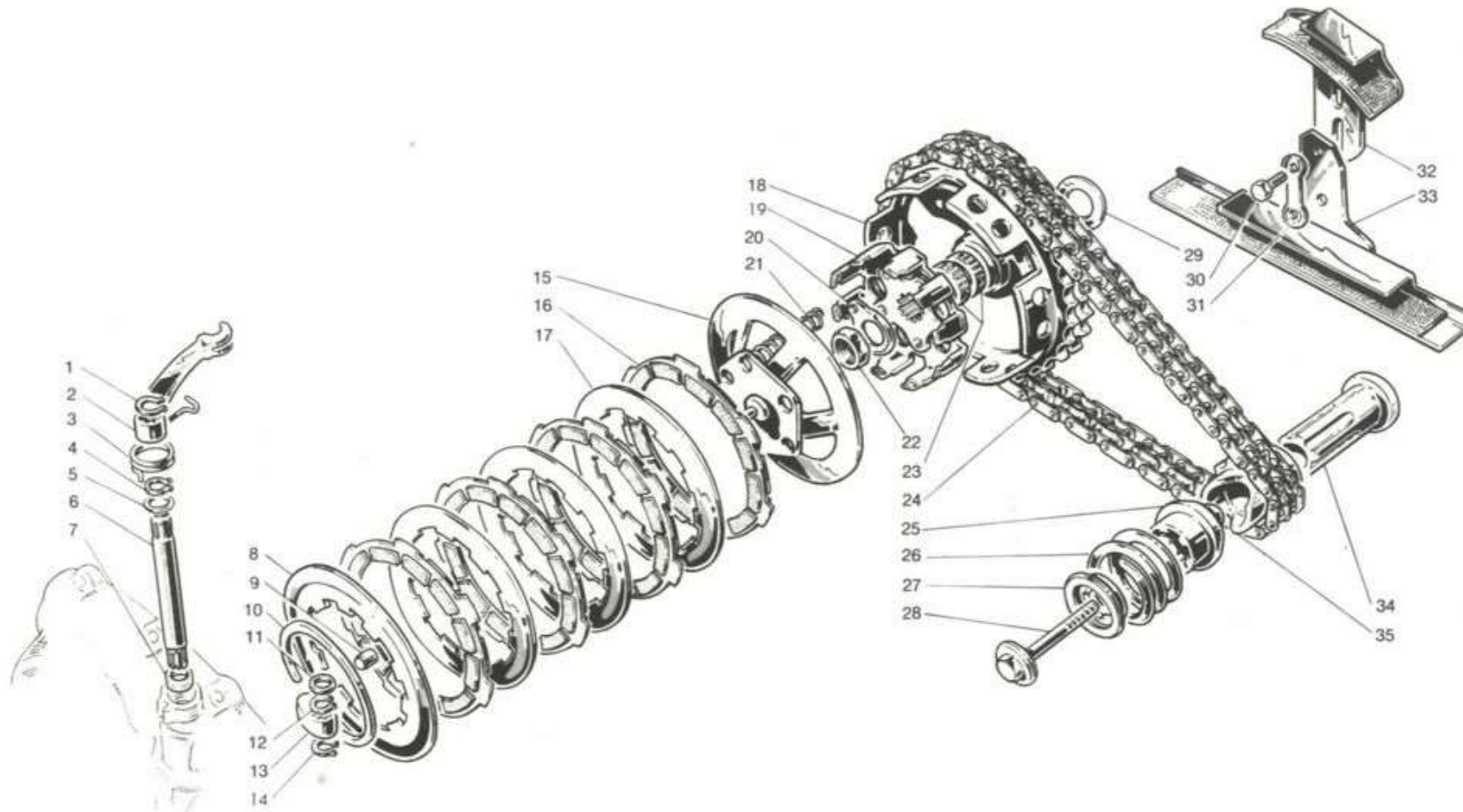

19 - 062



www.fpv.it

III
IV
V
VI
VII
VIII
IX
X
XI
XII
XIII
XIV
XV
XV
XV

Fig. Abb.	Ord. No. Bestell N.	Denominazione	Description	Désignation	Benennung	Qt. Anzahl	125 LI	125 S	150 LI	150 S	150 SX	175 TV	200 SX
29	19020022	Rondella spess. 0,8	Shim	Rondelle de réglage	Ausgleichscheibe	1	○	○	○	○	○	○	○
	19020032	Rondella spess. 1	Shim	Rondelle de réglage	Ausgleichscheibe	—	○	○	○	○	○	○	○
	19020033	Rondella spess. 1,2	Shim	Rondelle de réglage	Ausgleichscheibe	—	○	○	○	○	○	○	○
	19020034	Rondella spess. 1,4	Shim	Rondelle de réglage	Ausgleichscheibe	—	○	○	○	○	○	○	○
	19020035	Rondella spess. 1,6	Shim	Rondelle de réglage	Ausgleichscheibe	—	○	○	○	○	○	○	○
30	81008159	Vite	Screw	Vis	Schraube	2	○	○	○	○	○	○	○
31	19041022	Piastrina	Plate	Plaquette	Befestigungsblech	1	○	○	○	○	○	○	○
32	19041100	Guidacatena mobile	Chain stretcher	Tendeur de chaîne	Kettenspanner	1	○	○	○	○	○	○	○
33	19041110	Guidacatena fisso	Chain slide	Guide chaîne	Kettenführung	1	○	○	○	○	○	○	○
34	19012016	Manicotto	Sleeve	Manchon	Keilhülse	1	○	○	○	○	○	○	○
35	19012015	Pignone	Sprocket	Pignon	Kettenritzel	1	○	○	○	○	○	○	○

Questa catena va montata solo nel caso vengano sostituiti la corona 19920036 a Fig. 18 ed il pignone 19012015 a Fig. 35.

This chain is only fitted if crown wheel 19920036 - Fig. 18 and sprocket 19012015 - Fig. 35 are replaced.

★ Cette chaîne est seulement montée si la couronne 19920036 - Fig. 18 et le pignon 19012015 - Fig. 35 sont remplacés.

Diese Kette wird nur montiert, wenn Zahnrad 19920036 - Abb. 18 und das Kettenritzel 19012015 - Abb. 35 ersetzt werden.

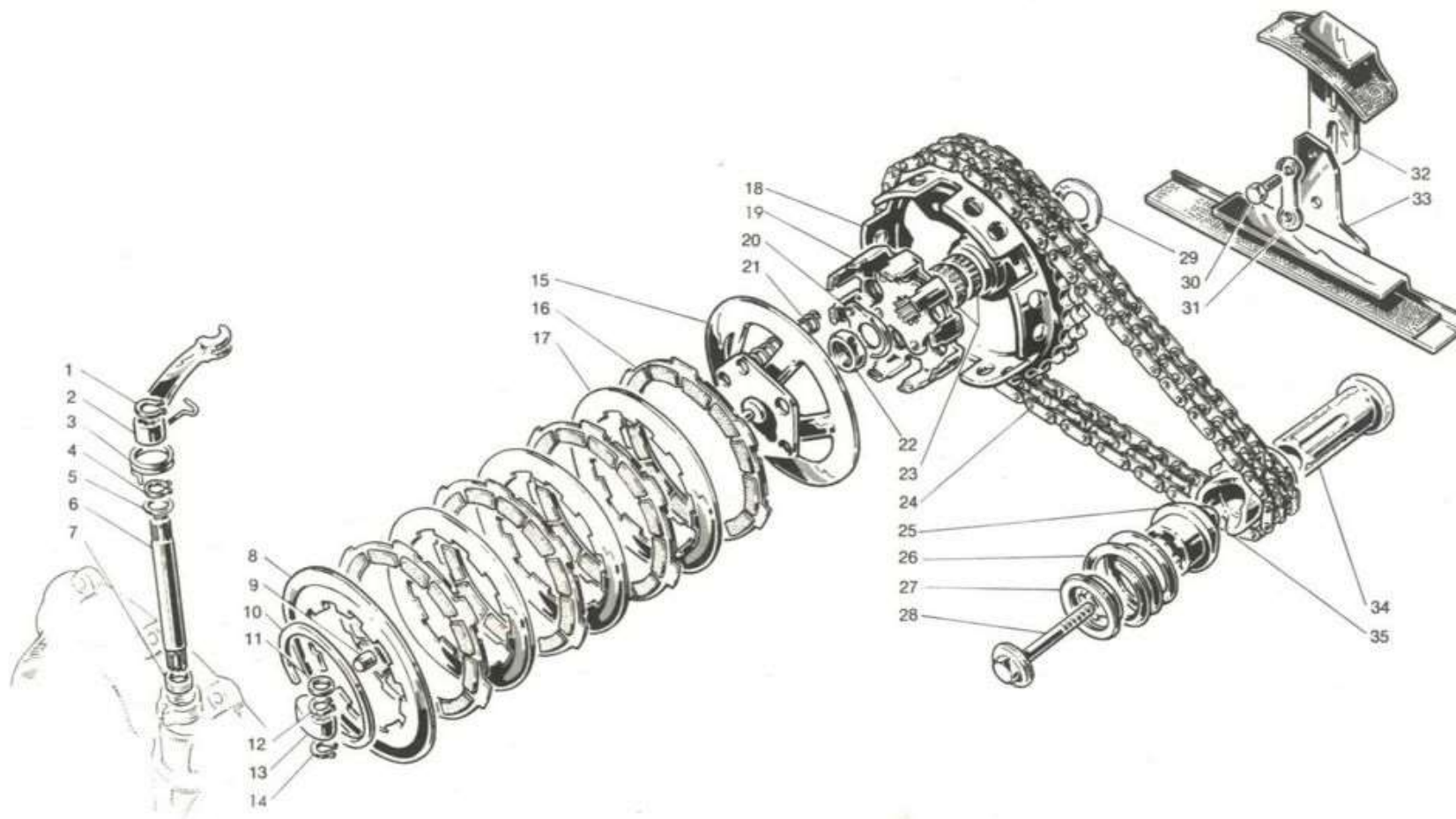

19 - 062



IV
V
VI
VII
VIII
IX
X
XI
XII
XIII
XIV
XV
XV
XV

www.rp...

Fig. Abb.	Ord. No. Bestell N.	Denominazione	Description	Désignation	Benennung	Qt. Anzahl	125 LI	125 S	150 LI	150 S	150 SX	175 TV	200 SX
1	19030034	Vite	Screw	Vis	Schraube	1	o	o	o	o	o	o	o
2	83100010	Rondella elastica	Spring washer	Rondelle élastique	Federscheibe	1	o	o	o	o	o	o	o
3	70300730	Vite	Screw	Vis	Schraube	1	o	o	o	o	o	o	o
4	83100007	Rondella elastica	Spring washer	Rondelle élastique	Federscheibe	1	o	o	o	o	o	o	o
5	73260020	Anello elastico	Circlip	Circlip	Seegerring	1	o	o	o	o	o	o	o
6	19030018	Dischetto	Disc	Disque	Scheibe	1	o	o	o	o	o	o	o
7	73250018	Anello elastico	Circlip	Circlip	Seegerring	1	o	o	o	o	o	o	o
8	19030014 +	Camma	Cam	Came	Führungsnocken	1	o	o	o	o	o	o	o
9	81008160 +	Vite	Screw	Vis	Schraube	3	o	o	o	o	o	o	o
10	83100006 +	Rondella elastica	Spring washer	Rondelle élastique	Federscheibe	3	o	o	o	o	o	o	o
11	19030016	Perno	Pin	Axe	Bolzen	1	o	o	o	o	o	o	o
12	19030015	Pistoncino	Piston	Piston	Anwerfklaue	1	o	o	o	o	o	o	o
13	19030017	Molla	Spring	Ressort	Feder	1	o	o	o	o	o	o	o
14	19030020	Gabbia a rullini	Needle cage	Cage à aiguilles	Nadelkäfig	1	o	o	o	o	o	o	o
15	19930031	Albero avviamento	Shaft	Axe	Anwerfwelle	1	o	o	o	o	o	o	o
16	19030046	Molla	Spring	Ressort	Feder	1	o	o	o	o	o	o	o
17	19010016	Anello di tenuta (22x32x5,5)	Oil seal	Anneau d'étanchéité	Dichtring	1	o	o	o	o	o	o	o
18	19030028	Rondella di rasamento	Shim	Rondelle de réglage	Ausgleichscheibe	1	o	o	o	o	o	o	o
19	19630029	Leva avviamento	K/Start lever	Levier démarrage	Anwerfkurbel	1							o
	19930029	Leva avviamento	K/Start lever	Levier démarrage	Anwerfkurbel	1	o	o	o	o	o	o	
20	19130042	Protezione	Rubber pad	Protection	Gummischutz	1	o	o	o	o	o	o	o
21	19030023	Rondella spess. 2	Shim	Rondelle de réglage	Ausgleichscheibe	1	o	o	o	o	o	o	o
	19030047	Rondella spess. 2,2	Shim	Rondelle de réglage	Ausgleichscheibe	—	o	o	o	o	o	o	o
	19030048	Rondella spess. 2,4	Shim	Rondelle de réglage	Ausgleichscheibe	—	o	o	o	o	o	o	o
22	19030044	Rondella rasamento	Shim	Rondelle de réglage	Ausgleichscheibe	1	o	o	o	o	o	o	o
23	19030033	Cuscinetto	Ball bearing	Roulement	Kugellager	1	o	o	o	o	o	o	o
24	73250042	Anello elastico	Circlip	Circlip	Seegerring	1	o	o	o	o	o	o	o
25	19030003 +	Ingranaggio I velocità	1st speed gear	Pignon 1ère vitesse	Zahnrad 1 Gang	1	o						
	19030003	Ingranaggio I velocità	1st speed gear	Pignon 1ère vitesse	Zahnrad 1 Gang	1			o	o			
	19130014 +	Ingranaggio I velocità	1st speed gear	Pignon 1ère vitesse	Zahnrad 1 Gang	1	o						

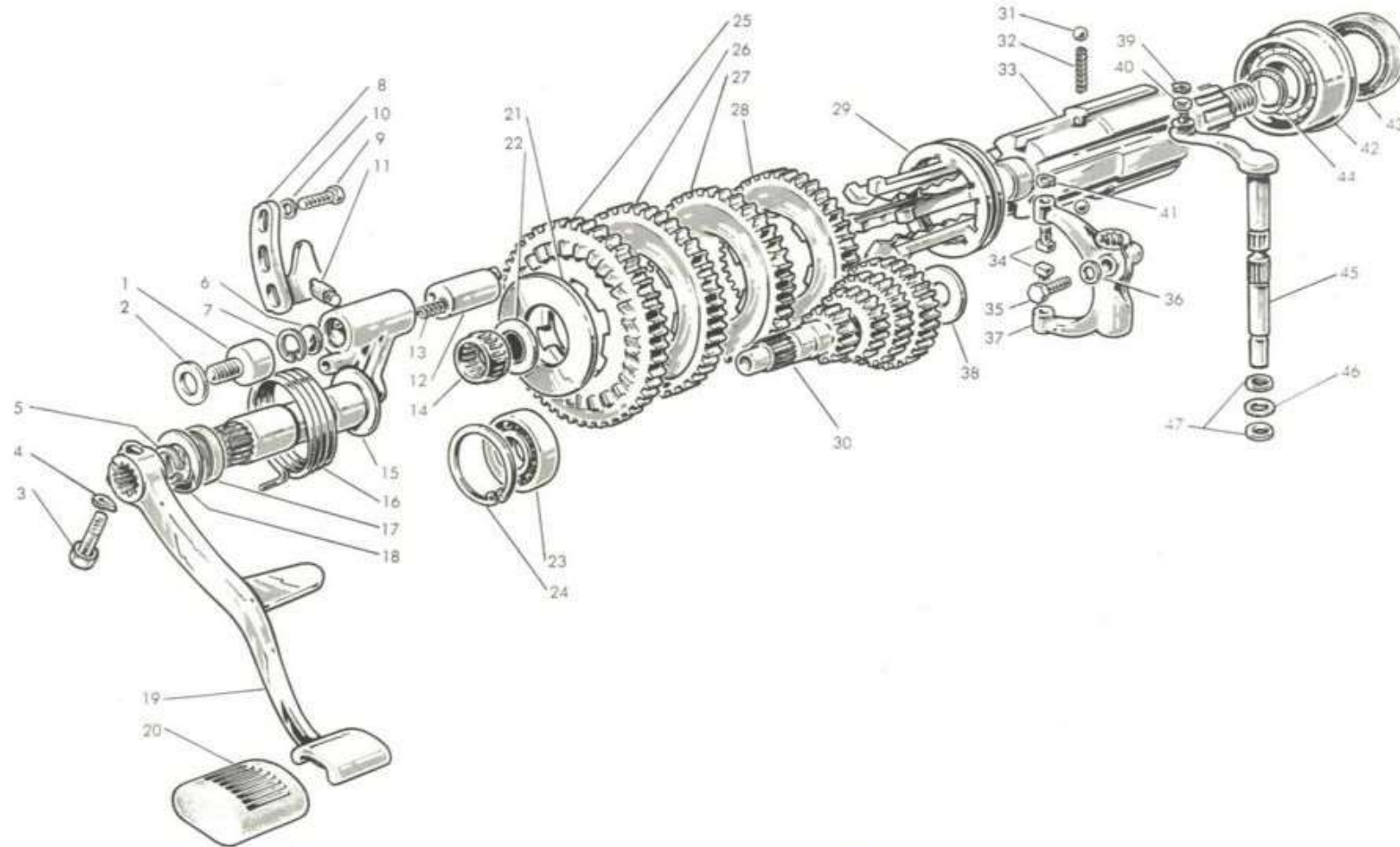

19-063

INNOCENTI

www.rp...

IV
V
VI
VII
VIII
IX
X
XI
XII
XIII
XIV
XV
XV
XV

Fig. Abb.	Ord. No. Bestell N.	Denominazione	Description	Désignation	Benennung	Qt. Anzahl	125 LI	125 S	150 LI	150 S	150 SX	175 TV	200 SX
25	19230003	Ingranaggio I velocità	1st speed gear	Pignon 1ère vitesse	Zahnrad 1 Gang	1						0	0
	19430008	Ingranaggio I velocità	1st speed gear	Pignon 1ère vitesse	Zahnrad 1 Gang	1		0			0		
26	19030004	Ingranaggio II velocità	2nd speed gear	Pignon 2ème vitesse	Zahnrad 2 Gang	1			0				
	19130015	✦ Ingranaggio II velocità	2nd speed gear	Pignon 2ème vitesse	Zahnrad 2 Gang	1	0						
	19230004	Ingranaggio II velocità	2nd speed gear	Pignon 2ème vitesse	Zahnrad 2 Gang	1						0	0
	19430009	Ingranaggio II velocità	2nd speed gear	Pignon 2ème vitesse	Zahnrad 2 Gang	1		0			0		
	19830009	✧ Ingranaggio II velocità	2nd speed gear	Pignon 2ème vitesse	Zahnrad 2 Gang	1	0						
	19830009	Ingranaggio II velocità	2nd speed gear	Pignon 2ème vitesse	Zahnrad 2 Gang	1				0			
27	19030005	Ingranaggio III velocità	3rd speed gear	Pignon 3ème vitesse	Zahnrad 3 Gang	1			0				
	19130016	✦ Ingranaggio III velocità	3rd speed gear	Pignon 3ème vitesse	Zahnrad 3 Gang	1	0						
	19230005	Ingranaggio III velocità	3rd speed gear	Pignon 3ème vitesse	Zahnrad 3 Gang	1						0	0
	19430011	Ingranaggio III velocità	3rd speed gear	Pignon 3ème vitesse	Zahnrad 3 Gang	1		0			0		
	19830005	✧ Ingranaggio III velocità	3rd speed gear	Pignon 3ème vitesse	Zahnrad 3 Gang	1	0						
28	19830005	Ingranaggio III velocità	3rd speed gear	Pignon 3ème vitesse	Zahnrad 3 Gang	1				0			
	19030006	Ingranaggio IV velocità	4th speed gear	Pignon 4ème vitesse	Zahnrad 4 Gang	1			0				
	19130017	✦ Ingranaggio IV velocità	4th speed gear	Pignon 4ème vitesse	Zahnrad 4 Gang	1	0						
	19130017	✧ Ingranaggio IV velocità	4th speed gear	Pignon 4ème vitesse	Zahnrad 4 Gang	1	0						
	19130017	Ingranaggio IV velocità	4th speed gear	Pignon 4ème vitesse	Zahnrad 4 Gang	1				0	0		
	19230006	Ingranaggio IV velocità	4th speed gear	Pignon 4ème vitesse	Zahnrad 4 Gang	1						0	0
29	19430012	Ingranaggio IV velocità	4th speed gear	Pignon 4ème vitesse	Zahnrad 4 Gang	1		0					
	41031007	Manicotto	Sliding dog	Manchon	Schaltklaue	1	0	0	0	0	0	0	0
30	19030001	Albero primario	Main shaft	Arbre primaire	Getriebewelle	1			0				
	19130013	✦ Albero primario	Main shaft	Arbre primaire	Getriebewelle	1	0						
	19230001	Albero primario	Main shaft	Arbre primaire	Getriebewelle	1						0	0
	19430007	Albero primario	Main shaft	Arbre primaire	Getriebewelle	1		0					
	19530501	Albero primario	Main shaft	Arbre primaire	Getriebewelle	1					0		
	19830001	✧ Albero primario	Main shaft	Arbre primaire	Getriebewelle	1	0						
31	19830001	Albero primario	Main shaft	Arbre primaire	Getriebewelle	1				0			
	78920516	Sfera	Ball	Bille	Kugel	2	0	0	0	0	0	0	0
32	19031008	Molletta	Spring	Ressort	Spannfeder	1	0	0	0	0	0	0	0

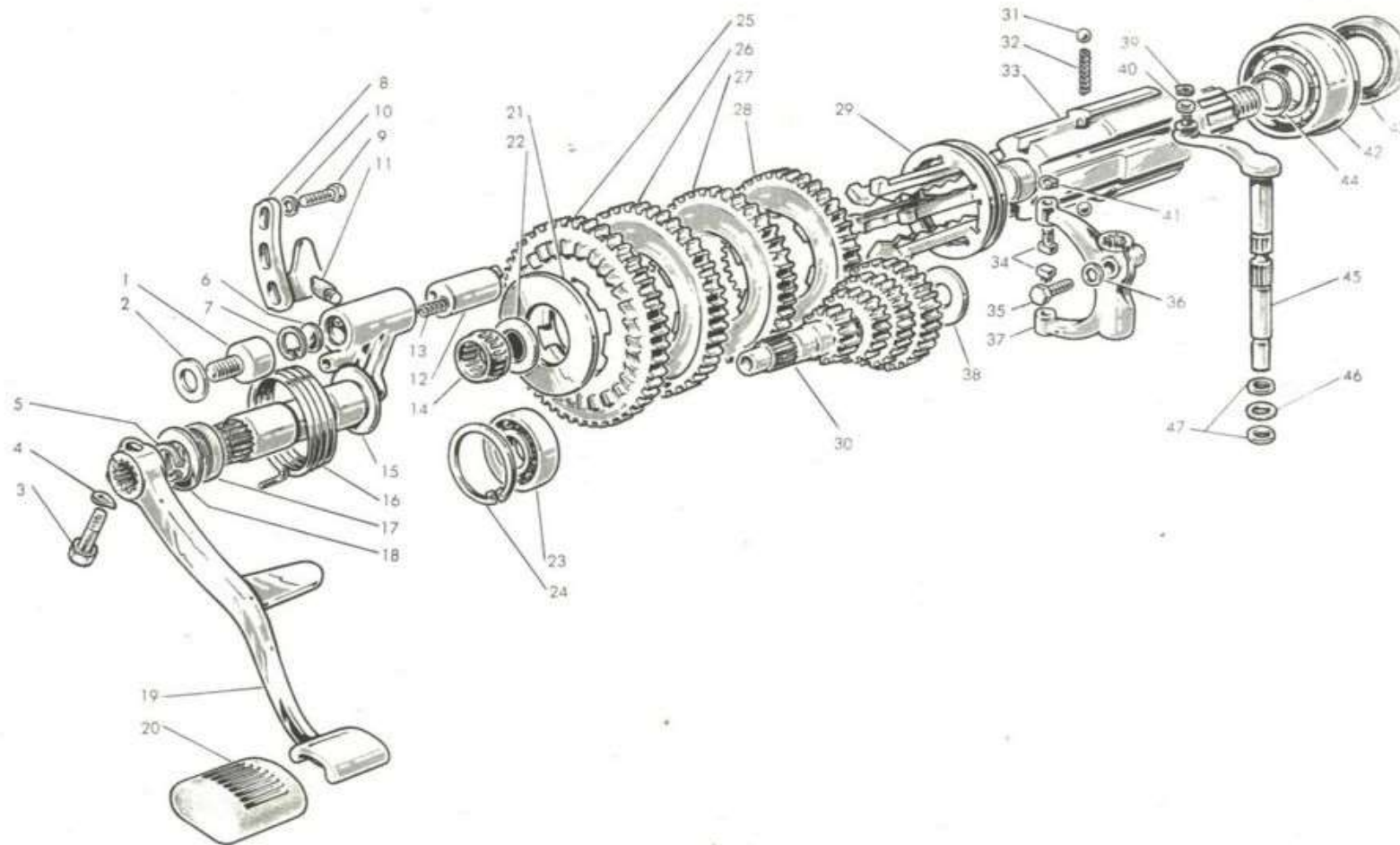

19-063



www.innocenti.com

V
VI
VII
VIII
IX
X
XI
XII
XIII
XIV
XV
XV
XV

Fig. Abb.	Ord. No. Bestell N.	Denominazione	Description	Désignation	Benennung	Qt. Anzahl	125 LI	125 S	150 LI	150 S	150 SX	175 TV	200 SX
33	19030002	Albero secondario	Layshaft	Arbre secondaire	Vorgelegewelle	1	o	o	o	o	o	o	o
34	19031014	Piolo	Pin	Axe	Bolzen	2	o	o	o	o	o	o	o
35	70450620	Vite	Screw	Vis	Schraube	1	o	o	o	o	o	o	o
36	83100006	Rondella elastica	Spring washer	Rondelle élastique	Federscheibe	1	o	o	o	o	o	o	o
37	19031002	Leva	Lever	Levier	Schalthebel	1	o	o	o	o	o	o	o
38	19030043	Rondella	Washer	Rondelle	Scheibe	1	o	o	o	o	o	o	o
39	73260006	Anello elastico	Circlip	Circlip	Seegerring	1	o	o	o	o	o	o	o
40	73030064	Rondella	Washer	Rondelle	Scheibe	1	o	o	o	o	o	o	o
41	73260005	Anello elastico	Circlip	Circlip	Seegerring	2	o	o	o	o	o	o	o
42	19030050	Cuscinetto con fig. 43	Ball bearing with fig. 43	Roulement avec fig. 43	Kugellager mit Abb. 43	1	o	o	o	o	o	o	o
43	19030036	Anello di tenuta	Oil seal	Anneau d'étanchéité	Dichtring	1	o	o	o	o	o	o	o
44	19030032	Anello di tenuta	Oil seal	Anneau d'étanchéité	Dichtring	1	o	o	o	o	o	o	o
45	19931018	Alberino con leva	Shaft	Arbre	Schaltspindel	1	o	o	o	o	o	o	o
46	19031013	Anello di tenuta	Oil seal	Anneau d'étanchéité	Dichtring	1	o	o	o	o	o	o	o
47	19031015	Rondella	Washer	Rondelle	Scheibe	2	o	o	o	o	o	o	o

⊕ { Pre-modifica.
Pre-modification.
Pré-modification.
Vor-Aenderung.

⊖ { Post-modifica.
Post-modification.
Post-modification.
Nach-Aenderung.

ATTENZIONE - Per maggior chiarezza consultare la tavola
ATTENTION - For clearness' sake, see also the Section
ATTENTION - Pour majeure précision, voir aussi la Planche
ACHTUNG - Für eine bessere Erläuterung, siehe auch die Tafel



- Rapporti cambio.
- Gearbox ratios.
- Rapports de boîte de vitesses.
- Wechselgetriebe-Übersetzungen.

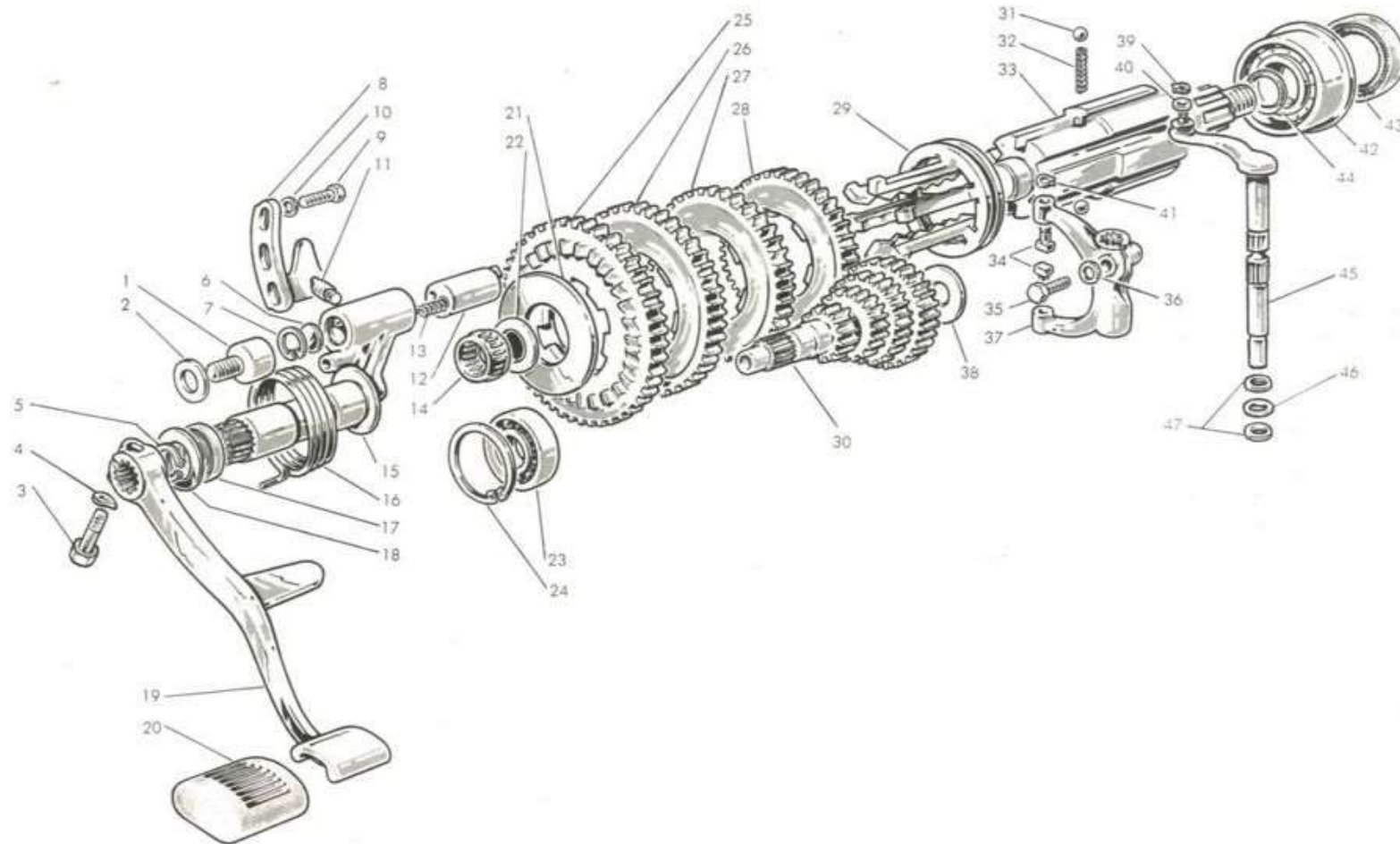

19-063



www.rp...

V
VI
VII
VIII
IX
X
XI
XII
XIII
XIV
XV
XV
XV

Fig. Abb.	Ord. No. Bestell N.	Denominazione	Description	Désignation	Benennung	Qt. Anzahl	125 LI	125 S	150 LI	150 S	150 SX	175 TV	200 SX
1	19010052	Flangia	Flange	Palier	Lagerflansch	1	○	○	○	○	○	○	○
2	19010015	Guarnizione	Gasket	Joint	Dichtung	1	○	○	○	○	○	○	○
3	82008010	Dado	Nut	Ecrou	Mutter	3	○	○	○	○	○	○	○
4	83100006	Rondella elastica	Spring washer	Rondelle élastique	Federscheibe	3	○	○	○	○	○	○	○
5	19014030	Coperchio con fig. 13	Cover with fig. 13	Couvercle avec fig. 13	Gebäsedeckel mit Abb. 13	1	○	○	○	○	○	○	○
6	73170053	Rondella elastica	Spring washer	Rondelle élastique	Federscheibe	5	○	○	○	○	○	○	○
7	19014003	Vite	Screw	Vis	Schraube	5	○	○	○	○	○	○	○
8	73170053	Rondella elastica	Spring washer	Rondelle élastique	Federscheibe	2	○	○	○	○	○	○	○
9	19014003	Vite	Screw	Vis	Schraube	2	○	○	○	○	○	○	○
10	19214020	Cuffia	Cylinder cowl	Coiffe	Zylinderhaube	1	○	○	○	○	○	○	○
11	83100008	Rondella elastica	Spring washer	Rondelle élastique	Federscheibe	1	○	○	○	○	○	○	○
12	81008219	Vite	Screw	Vis	Schraube	1	○	○	○	○	○	○	○
13	65000100	Tappo	Plug	Bouchon	Stopfen	4	○	○	○	○	○	○	○

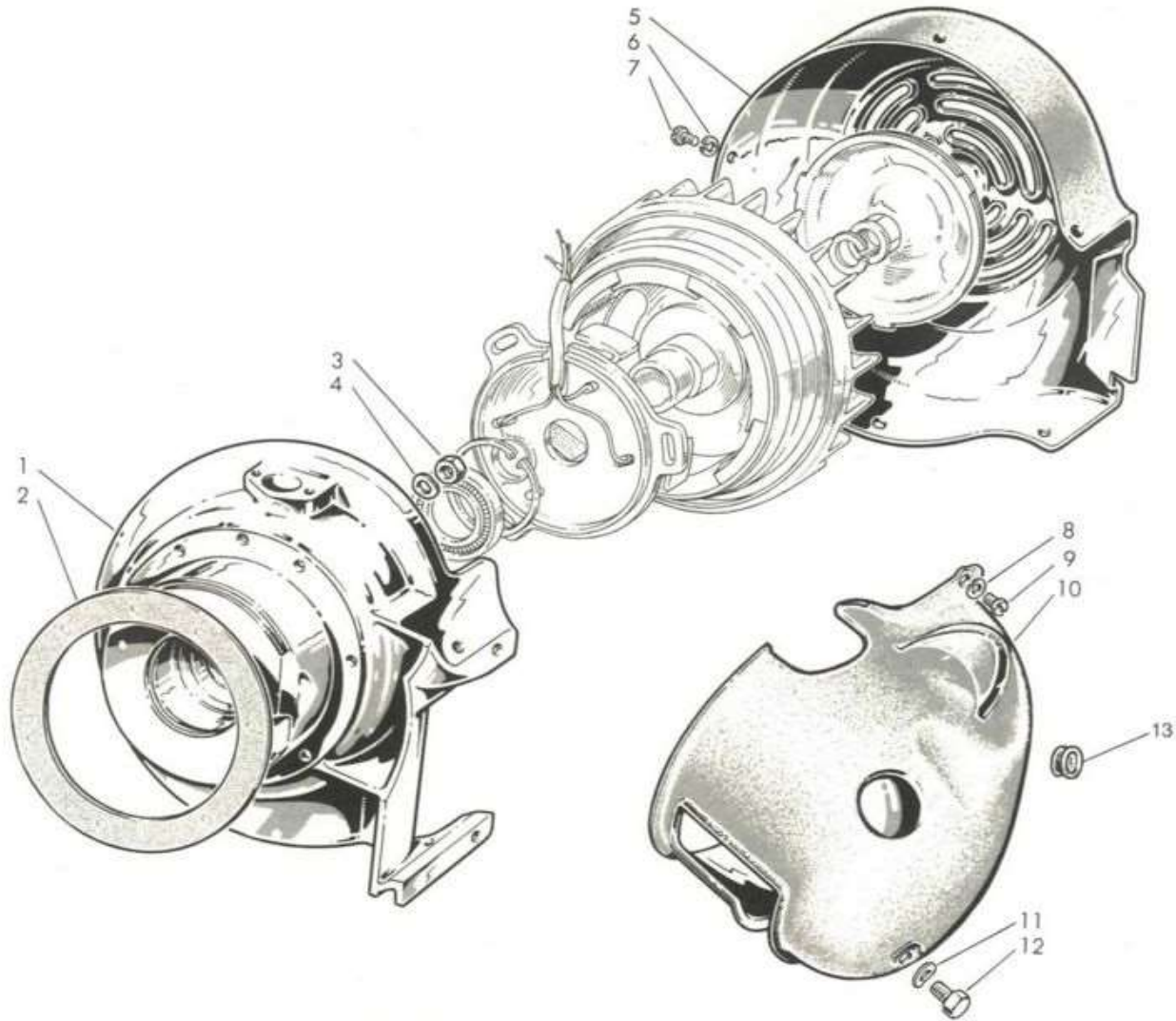

19-064



www.innocenti.com

V
VI
VII
VIII
IX
X
XI
XII
XIII
XIV
XV
XV
XV

Fig. Abb.	Ord. No. Bestell N.	Denominazione	Description	Désignation	Benennung	Qt. Anzahl	125 LI	125 S	150 LI	150 S	150 SX	175 TV	200 SX
-	00412441	■ Carburatore	Carburettor	Carburateur	Vergaser	1	o		o	o			
-	00412442	■ Carburatore	Carburettor	Carburateur	Vergaser	1		o			o		
-	00412443	■ Carburatore	Carburettor	Carburateur	Vergaser	1						o	o
1	00412341	Vite	Screw	Vis	Schraube	1	o	o	o	o	o	o	o
2	00412394	Guarnizione	Gasket	Joint	Dichtung	1	o	o	o	o	o	o	o
3	00412331	Pipetta	Cover	Couvercle	Deckel	1	o	o	o	o	o	o	o
4	00412299	Guarnizione	Gasket	Joint	Dichtung	1	o	o	o	o	o	o	o
5	00412298	Filtro	Filter	Filtre	Filter	1	o	o	o	o	o	o	o
6	00412062	Vite	Screw	Vis	Schraube	1	o	o	o	o	o	o	o
7	00412248	Morsetto	Clamp	Collier	Klemmring	1	o	o	o	o	o	o	o
8	73170043	Rondella elastica	Spring washer	Rondelle élastique	Federscheibe	1	o	o	o	o	o	o	o
9	00412048	Perno	Pin	Pivot	Bolzen	1	o	o	o	o	o	o	o
10	00412192	Vite	Screw	Vis	Schraube	1	o	o	o	o	o	o	o
11	00412330	Leva	Lever	Levier	Hebel	1	o	o	o	o	o	o	o
12	00412191	Molla	Spring	Ressort	Feder	1	o	o	o	o	o	o	o
13	00412038	Guarnizione	Gasket	Joint	Dichtung	1	o	o	o	o	o	o	o
14	00412333	Coperchio	Cover	Couvercle	Deckel	1	o	o	o	o	o	o	o
15	00412338	Molla	Spring	Ressort	Feder	1	o	o	o	o	o	o	o
16	00412396	Valvola gas	Throttle slide	Boisseau de gas	Gasschieber	1	o			o		o	o
	00412437	Valvola gas	Throttle slide	Boisseau de gas	Gasschieber	1		o	o		o		
17	00412261	Riduzione isolante	Insulating reduction	Anneau isolant	Isolierbüchse	1	o	o	o	o	o	o	o
18	00412398	Getto starter da 50	Starter jet	Gicleur starter	Starterdüse	1	o	o	o	o	o	o	o
19	00412321	Spillo conico	Needle	Aiguille	Düsennadel	1	o	o	o	o	o	o	o
20	00412349	Perno	Pin	Pivot	Bolzen	1	o	o	o	o	o	o	o
21	00412049	Dado	Nut	Ecrou	Mutter	1	o	o	o	o	o	o	o
22	00412071	Tirante	Tie rod	Tirant	Zugstange	1	o	o	o	o	o	o	o
23	00412053	Cappuccio	Cap	Chapeau	Haube	1	o	o	o	o	o	o	o
24	00412193	Vite	Screw	Vis	Schraube	2	o	o	o	o	o	o	o
25	00412054	Dado	Nut	Ecrou	Mutter	1	o	o	o	o	o	o	o
26	00412055	Vite	Screw	Vis	Schraube	1	o	o	o	o	o	o	o

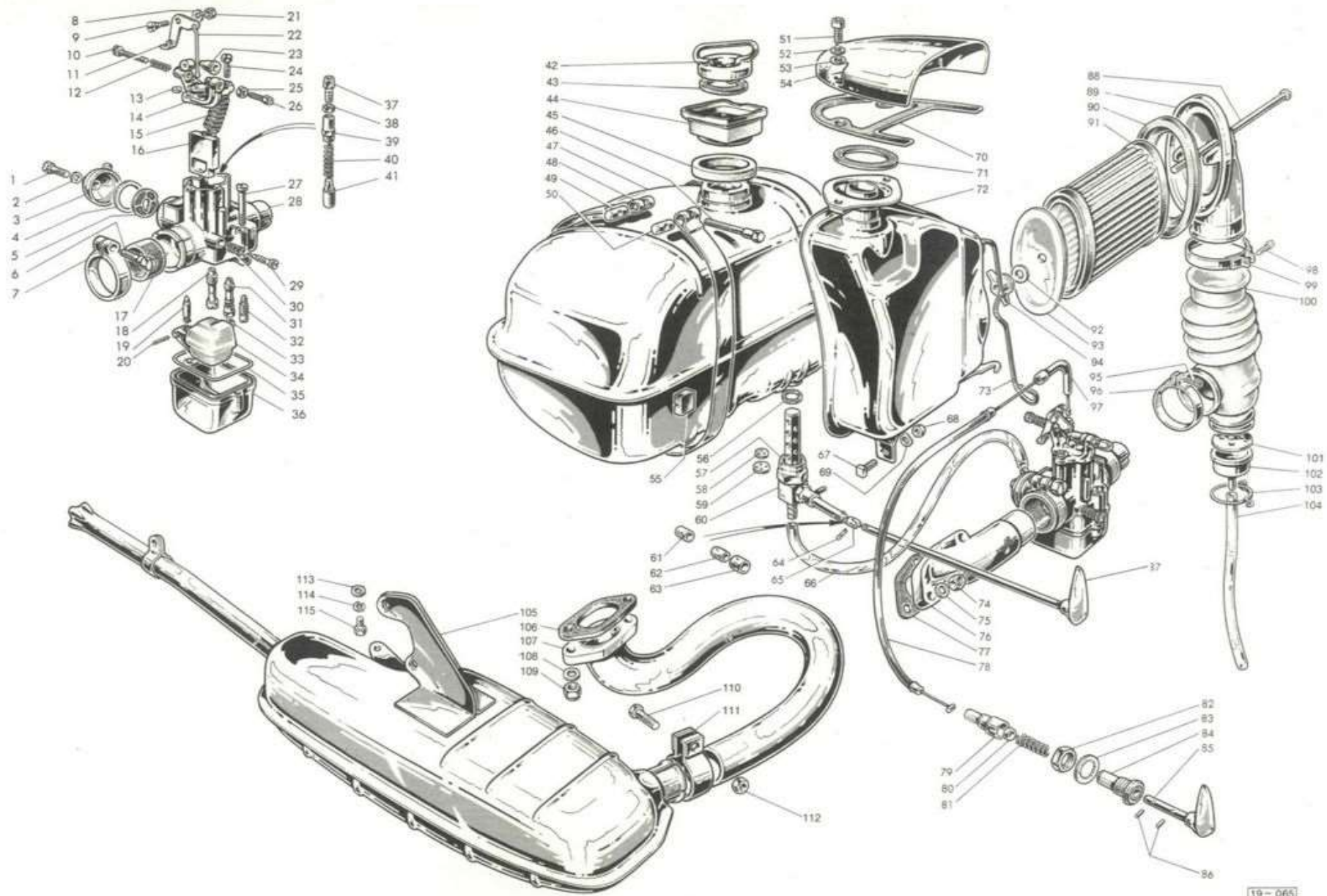

19-065



www.rp...

VI
VII
VIII
IX
X
XI
XII
XIII
XIV
XV
XV
XV

Fig. Abb.	Ord. No. Bestell N.	Denominazione	Description	Désignation	Benennung	Qt. Anzahl	125 LI	125 S	150 LI	150 S	150 SX	175 TV	200 SX
27	00412342	Vite	Screw	Vis	Schraube	2	o	o	o	o	o	o	o
28	—	* Corpo carburatore	Carburettor body	Corps carburateur	Vergasergehäuse	—							
29	00412343	Vite	Screw	Vis	Schraube	1	o	o	o	o	o	o	o
30	00412344	Molla	Spring	Ressort	Feder	1	o	o	o	o	o	o	o
31	00412339	Emulsionatore	Diffuser	Diffuseur	Diffusor	1	o		o				
	00412402	Emulsionatore	Diffuser	Diffuseur	Diffusor	1				o		o	o
	00412436	◇ Emulsionatore	Diffuser	Diffuseur	Diffusor	1		o					
	00412436	Emulsionatore	Diffuser	Diffuseur	Diffusor	1					o		
	00412444	† Emulsionatore	Diffuser	Diffuseur	Diffusor	1		o					
32	00412346	Getto minimo da 42	Pilot jet	Gicleur du ralenti	Leerlaufdüse	1	o						
	00412351	Getto minimo da 50	Pilot jet	Gicleur du ralenti	Leerlaufdüse	1						o	
	00412353	Getto minimo da 48	Pilot jet	Gicleur du ralenti	Leerlaufdüse	1							o
	00412404	Getto minimo da 45	Pilot jet	Gicleur du ralenti	Leerlaufdüse	1		o	o	o	o		
33	00412256	Getto max. da 105	Main jet	Gicleur principal	Hauptdüse	1			o				
	00412347	Getto max. da 106	Main jet	Gicleur principal	Hauptdüse	1						o	
	00412348	Getto max. da 99	Main jet	Gicleur principal	Hauptdüse	1	o						
	00412358	Getto max. da 101	Main jet	Gicleur principal	Hauptdüse	1				o			
	00412407	Getto max. da 103	Main jet	Gicleur principal	Hauptdüse	1							o
	00412408	† Getto max. da 107	Main jet	Gicleur principal	Hauptdüse	1		o					
	00412435	◇ Getto max. da 98	Main jet	Gicleur principal	Hauptdüse	1		o					
	00412440	Getto max. da 102	Main jet	Gicleur principal	Hauptdüse	1					o		
34	00412328	Galleggiante	Float	Flotteur	Schwimmer	1	o	o	o	o	o	o	o
35	00412337	Guarnizione	Gasket	Joint	Dichtung	1	o	o	o	o	o	o	o
36	00412329	Vaschetta	Float chamber	Cuvette	Schwimmergehäuse	1	o	o	o	o	o	o	o
37	00412148	Vite	Screw	Vis	Schraube	1	o	o	o	o	o	o	o
38	00412054	Dado	Nut	Ecrou	Mutter	1	o	o	o	o	o	o	o
39	00412181	Tappo	Plug	Bouchon	Stopfen	1	o	o	o	o	o	o	o
40	00412182	Molla	Spring	Ressort	Feder	1	o	o	o	o	o	o	o
41	00412140	Valvola starter	Choke valve	Soupape starter	Luftschieber	1	o	o	o	o	o	o	o
42	19070040	Tappo	Cap	Couvercle	Deckel	1	o	o	o	o	o	o	o

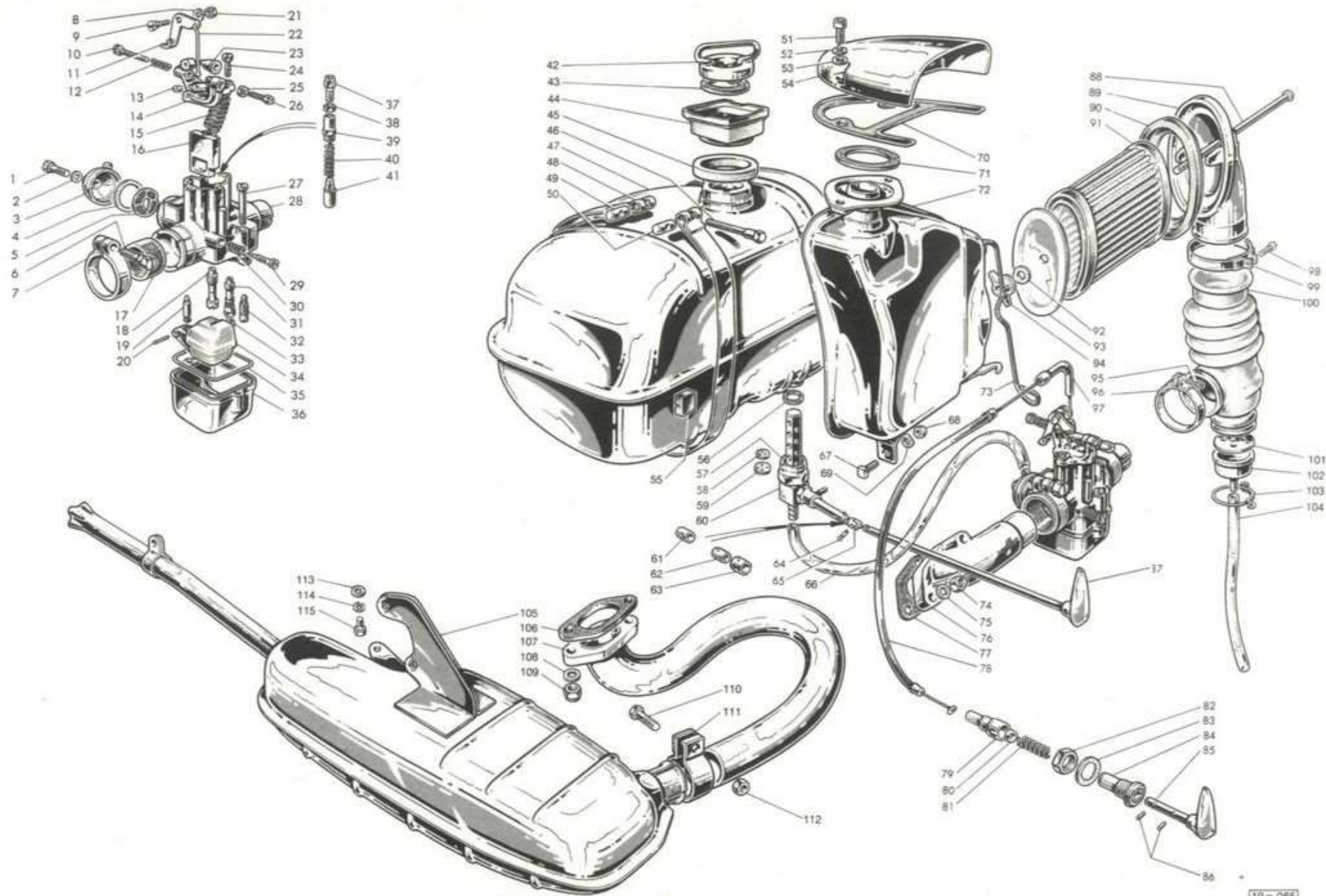

19-065



www.rpww.com

VII
VIII
IX
X
XI
XII
XIII
XIV
XV
XVI
XVII

Fig. Abb.	Ord. No. Bestell N.	Denominazione	Description	Désignation	Benennung	Qt. Anzahl	125 LI	125 S	150 LI	150 S	150 SX	175 TV	200 SX
43	15070021	Guarnizione	Gasket	Joint	Dichtung	1	o	o	o	o	o	o	o
44	19970018	Parapolvere	Dust cover	Couvercle	Staubdeckel	1	o	o	o	o	o	o	o
45	19970017	Guarnizione	Gasket	Joint	Dichtung	1	o	o	o	o	o	o	o
46	19970015	Vite	Screw	Vis	Schraube	2	o	o	o	o	o	o	o
47	19970010	Serbatoio	Tank	Réservoir	Behälter	1	o	o	o	o	o	o	o
48	19070011	Fascia	Strap	Collier	Spannband	2	o	o	o	o	o	o	o
49	15070013	Cilindretto	Trunnion	Barillet	Spannbolzen	2	o	o	o	o	o	o	o
50	15070014	Cilindretto	Trunnion	Barillet	Spannbolzen	2	o	o	o	o	o	o	o
51	71060618	Vite	Screw	Vis	Schraube	2	o	o	o	o	o	o	o
52	83050616	Rondella elastica	Spring washer	Rondelle élastique	Federscheibe	2	o	o	o	o	o	o	o
53	83010641	Rondella	Washer	Rondelle	Scheibe	2	o	o	o	o	o	o	o
54	19916019	Bocchetta	Air intake	Prise d'air	Luft Eintrittshaube	1	o	o	o	o	o	o	o
55	15070019	Tampone	Buffer	Tampon	Puffer	4	o	o	o	o	o	o	o
56	19071008	Guarnizione	Gasket	Joint	Dichtung	1	o	o	o	o	o	o	o
57	19071007	Dado	Nut	Ecrou	Mutter	1	o	o	o	o	o	o	o
58	19071013	Guarnizione	Gasket	Joint	Dichtung	1	o	o	o	o	o	o	o
59	19071012	Guarnizione	Gasket	Joint	Dichtung	1	o	o	o	o	o	o	o
60	19971030	Rubinetto	Tap	Robinet	Hahn	1	o	o	o	o	o	o	o
61	19071016	Bussola elastica	Antishock bush	Bague élastique	Elastische Büchse	1	o	o	o	o	o	o	o
62	19071015	Bussola elastica	Antishock bush	Bague élastique	Elastische Büchse	1	o	o	o	o	o	o	o
63	19071014	Bussola	Bush	Bague	Büchse	1	o	o	o	o	o	o	o
64	19071011	Spinetta	Plug pin	Axe	Stift	1	o	o	o	o	o	o	o
	74400228	Copiglia	Split pin	Goupille	Splint	2	o	o	o	o	o	o	o
65	19071009	Snodo	Articulating joint	Joint articulé	Gelenk	1	o	o	o	o	o	o	o
66	19971004	Tubazione	Line	Tube	Schlauch	1	o	o	o	o	o	o	o
67	19016029	Vite	Screw	Vis	Schraube	1	o	o	o	o	o	o	o
68	82058010	Dado	Nut	Ecrou	Mutter	1	o	o	o	o	o	o	o
69	83100006	Rondella elastica	Spring washer	Rondelle élastique	Federscheibe	1	o	o	o	o	o	o	o
70	19916042	Guarnizione	Gasket	Joint	Dichtung	1	o	o	o	o	o	o	o
71	19916051	Guarnizione	Gasket	Joint	Dichtung	1	o	o	o	o	o	o	o

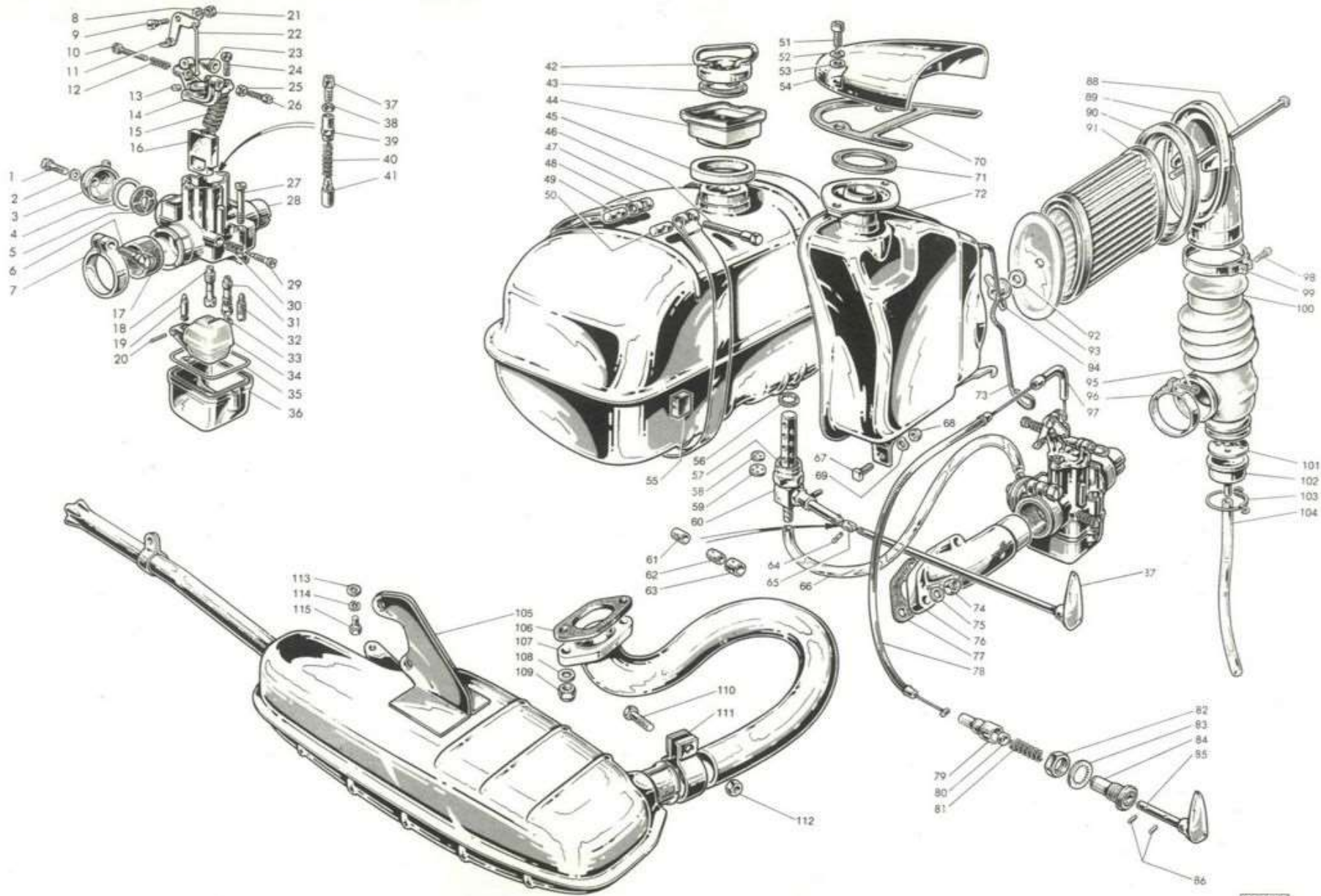

19-065

www.rpww.com

VII
VIII
IX
X
XI
XII
XIII
XIV
XV
XV
XV

Fig. Abb.	Ord. No. Bestell N.	Denominazione	Description	Désignation	Benennung	Qt. Anzahl	125 LI	125 S	150 LI	150 S	180 SX	175 TV	200 SX
72	19916250	Scatola filtro con fig. 73	Filter housing with fig. 73	Boîte de filtre avec fig. 73	Luftfiltergehäuse mit Abb. 73	1	o	o	o	o	o	o	o
73	19016058	Molla	Spring	Ressort	Feder	1	o	o	o	o	o	o	o
74	19011009	Dado	Nut	Ecrou	Mutter	2	o	o	o	o	o	o	o
75	83100007	Rondella elastica	Spring washer	Rondelle élastique	Federscheibe	2	o	o	o	o	o	o	o
76	19411004	Pipa	Manifold	Pipe	Krümmmer	1		o			o		
	19611004	Pipa	Manifold	Pipe	Krümmmer	1				o		o	
	19711004	Pipa	Manifold	Pipe	Krümmmer	1	o		o				
	19911004	Pipa	Manifold	Pipe	Krümmmer	1				o		o	
77	19211017	Guarnizione	Gasket	Joint	Dichtung	1				o		o	
	19611017	Guarnizione	Gasket	Joint	Dichtung	1							o
	19911017	Guarnizione	Gasket	Joint	Dichtung	1	o	o	o		o		
78	19015050	Cavo starter	Choke cable	Câble de starter	Starterkabel	1	o	o	o	o	o	o	o
79	19015023	Guida	Retainer	Guide	Führung	1	o	o	o	o	o	o	o
80	19015022	Scodellino	Cup	Cuvette	Teller	1	o	o	o	o	o	o	o
81	19015021	Molla	Spring	Ressort	Feder	1	o	o	o	o	o	o	o
82	15015015	Dado	Nut	Ecrou	Mutter	1	o	o	o	o	o	o	o
83	83120016	→ Rondella elastica	Spring washer	Rondelle élastique	Federscheibe	1	o	o	o	o	o	o	o
84	19915070	Bussola	Bush	Bague	Büchse	1	o	o	o	o	o	o	o
85	19915020	Levetta	Lever	Levier	Hebel	1	o	o	o	o	o	o	o
86	15015009	Piolino	Pin	Pivot	Stift	2	o	o	o	o	o	o	o
87	19971050	Levetta	Lever	Levier	Hebel	1	o	o	o	o	o	o	o
	19971070	Levetta	Lever	Levier	Hebel	1	o	o	o	o	o	o	o
88	19016059	Tirante	Tie rod	Tirant	Zugstange	1	o	o	o	o	o	o	o
89	19916018	Pipa aspirazione	Inlet manifold	Pipe d'admission	Ansaugkrümmer	1	o	o	o	o	o	o	o
90	19916057	Guarnizione	Gasket	Joint	Dichtung	1	o	o	o	o	o	o	o
91	19016270	Filtro	Element	Élément	Einsatz	1	o	o	o	o	o	o	o
92	19016062	Rondella	Washer	Rondelle	Scheibe	1	o	o	o	o	o	o	o
93	19016024	Fondello	Bottom	Culot	Filterlage	1	o	o	o	o	o	o	o
94	19916061	Dado ad alette	Wing nut	Ecrou à oreilles	Flügelmutter	1	o	o	o	o	o	o	o
95	71160420	Vite	Screw	Vis	Schraube	1	o	o	o	o	o	o	o

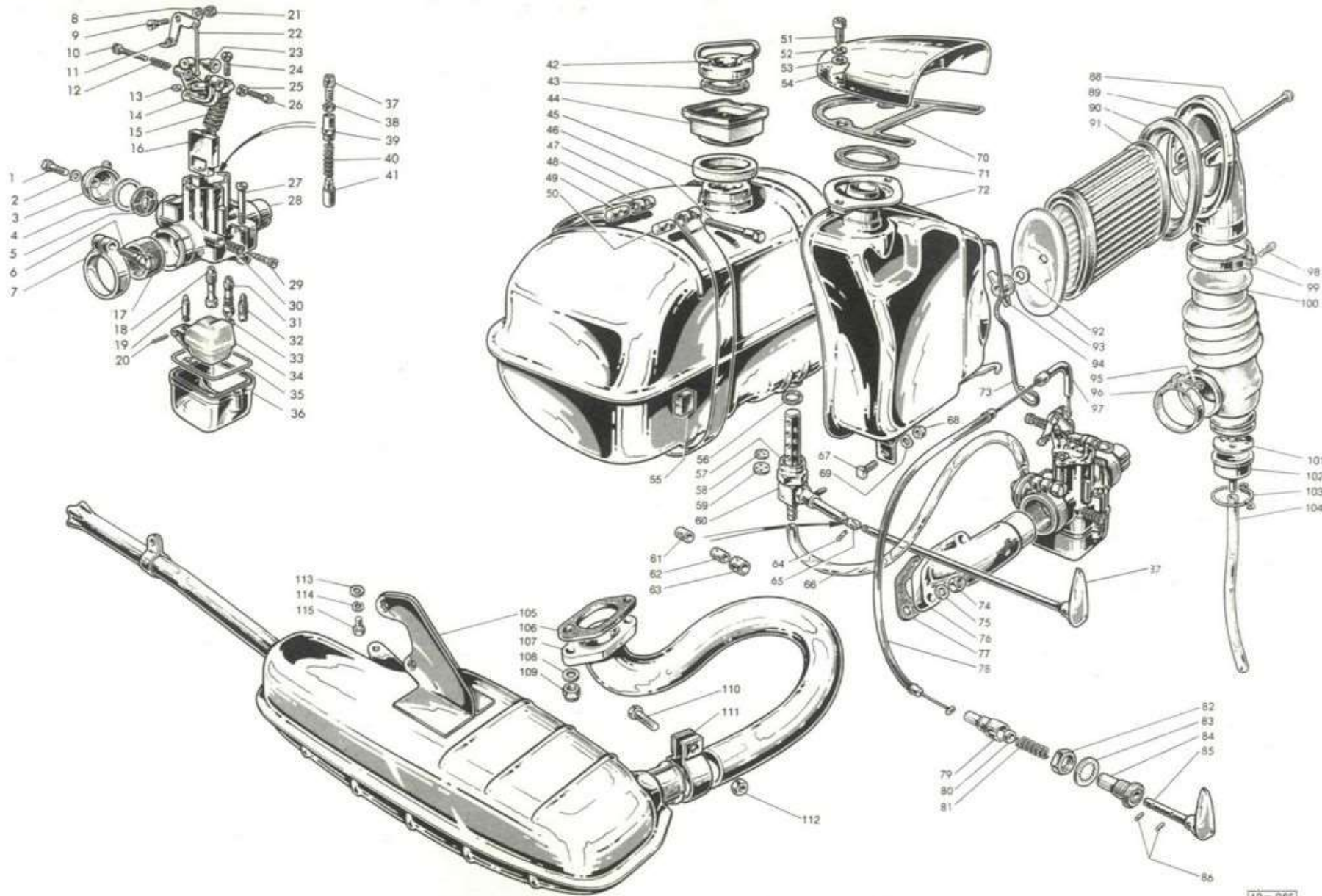

19-D65



www.rpv.it

VII
VIII
IX
X
XI
XII
XIII
XIV
XV
XV
XV

Fig. Abb.	Ord. No. Bestell N.	Denominazione	Description	Désignation	Benennung	Qt. Anzahl							
							125 LI	125 S	150 LI	150 S	150 SX	175 TV	200 SX
96	19916150	Fascetta	Clip	Collier	Klemmschelle	1	o	o	o	o	o	o	o
97	19015019	Tubetto	Tube	Tube	Krümmen	1	o	o	o	o	o	o	o
98	71160425	Vite	Screw	Vis	Schraube	1	o	o	o	o	o	o	o
99	19916160	Fascetta	Clip	Collier	Klemmschelle	1	o	o	o	o	o	o	o
100	19916021	Soffietto elastico	Elastic hose	Soufflet élastique	Elastischer Balg	1	o	o	o	o	o	o	o
101	41016070	Valvola	Valve	Soupape	Ventil	1	o	o	o	o	o	o	o
102	19916036	Scodellino	Cup	Cuvette	Teiler	1	o	o	o	o	o	o	o
103	19016037	Anello elastico	Spring ring	Anneau élastique	Federring	1	o	o	o	o	o	o	o
104	19016039	Tubetto	Tube	Tube	Krümmen	1	o	o	o	o	o	o	o
105	19518510	Marmitta	Silencer	Silencieux	Schalldämpfer	1					o		
	19918060	Marmitta	Silencer	Silencieux	Schalldämpfer	1	o	o	o	o		o	o
106	19018001	Guarnizione	Gasket	Joint	Dichtung	1	o	o	o	o	o	o	o
107	19518010	Tubo di scarico	Exhaust tube	Tuyau d'échappement	Auslassrohr	1	o	o	o	o	o	o	o
108	83100007	Rondella elastica	Spring washer	Rondelle élastique	Federscheibe	2	o	o	o	o	o	o	o
109	19018003	Dado	Nut	Ecrou	Mutter	2	o	o	o	o	o	o	o
110	81428378	Vite	Screw	Vis	Schraube	1	o	o	o	o	o	o	o
111	41018080	Morsetto	Clamp	Collier	Klemmschelle	1	o	o	o	o	o	o	o
112	82078012	Dado	Nut	Ecrou	Mutter	1	o	o	o	o	o	o	o
113	73021084	Rondella	Washer	Rondelle	Scheibe	1	o	o	o	o	o	o	o
114	83070820	Rondella elastica	Spring washer	Rondelle élastique	Federscheibe	1	o	o	o	o	o	o	o
115	81008222	Vite	Screw	Vis	Schraube	1	o	o	o	o	o	o	o

■ { ATTENZIONE: Vedi Tavola - - Regolazione Carburatori.
 ATTENTION: See the table - - Carburettor Adjustment.
 ATTENTION: Voir la table - ★ - Réglage Carburateurs.
 ACHTUNG: Siehe die Tafel - - Vergasereinstellung.

✦ { Pre-modifica.
 Pre-modification.
 Pré-modification.
 Vor-Aenderung.

✧ { Post-modifica.
 Post-modification.
 Post-modification.
 Nach-Aenderung.

★ { Non si fornisce a ricambio.
 Is not supplied as a spare part.
 N'est pas fourni comme pièce détachée.
 Wird nicht als Ersatzteil geliefert.

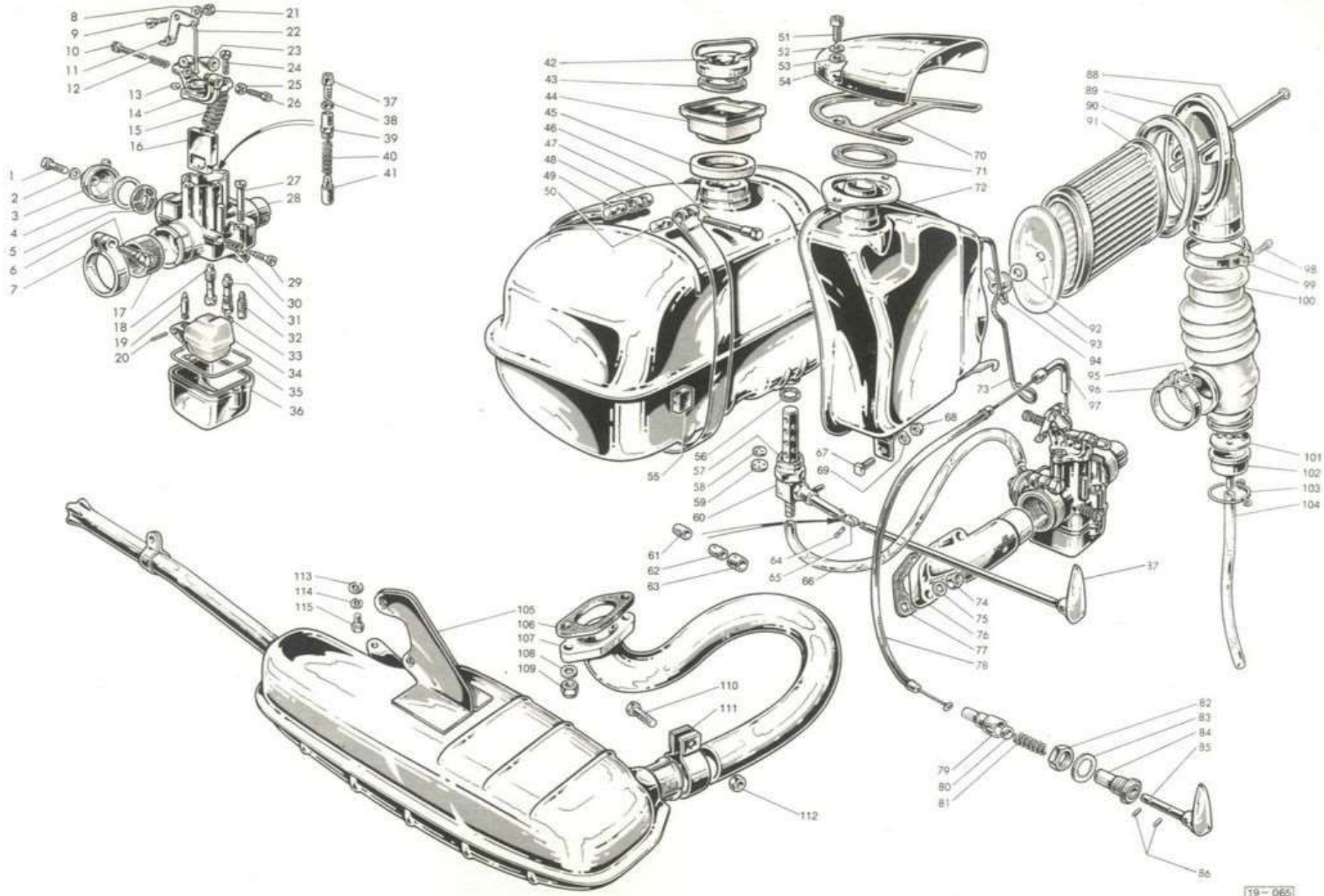

19-065



www.rp...

VII
VIII
IX
X
XI
XII
XIII
XIV
XV
XV
XV

Fig. Abb.	Ord. No. Bestell N.	Denominazione	Description	Désignation	Benennung	Qt. Anzahl							
							125 LI	125 S	150 LI	150 S	150 SX	175 TV	200 SX
1	19550580	❖ Telaio	Frame	Châssis	Fahrgestell	1	o	o	o	o	o	o	o
	19950030	+ Telaio	Frame	Châssis	Fahrgestell	1	o		o	o		o	
2	15055040	Sportello	Cover	Couvercle	Deckel	1	o	o	o	o	o	o	o
3	15055033	Perno	Pin	Pivot	Bolzen	1	o	o	o	o	o	o	o
4	19955050	Sportello con figg. 6-7-8	Cover with fig. 6-7-8	Couvercle avec fig. 6-7-8	Deckel mit Abb. 6-7-8	1	o	o	o	o	o	o	o
5	19955021	Perno	Pin	Pivot	Bolzen	1	o	o	o	o	o	o	o
6	19955060	Serratura con fig. 7	Lock with fig. 7	Serrure avec fig. 7	Schloss mit Abb. 7	1	o	o	o	o	o	o	o
7	00205501	Chiavi	Keys	Clés	Schlüssel	2	o	o	o	o	o	o	o
8	75710308	Ribattino	Rivet	Rivet	Niet	2	o	o	o	o	o	o	o
9	19955094	Tappo	Plug	Bouchon	Stopfen	4	o	o	o	o	o	o	o
10	19958100	Ammortizzatore	Shock absorber	Amortisseur	Stossdämpfer	1	o	o	o	o	o	o	o
11	19058090	Silentbloc	Silentblock	Silentbloc	Silentblock	2	o	o	o	o	o	o	o
12	19058017	Molla	Spring	Ressort	Feder	1	o	o	o	o	o	o	o
13	19058019	Anello	Ring	Anneau	Ring	1	o	o	o	o	o	o	o
14	19058018	Molla	Spring	Ressort	Feder	1	o	o	o	o	o	o	o
15	19958044	Anello	Ring	Anneau	Ring	1	o	o	o	o	o	o	o
16	19958045	Semianello	Half ring	Demi-anneau	Ringhälfte	2	o	o	o	o	o	o	o
17	72070016	Dado	Nut	Ecrou	Mutter	2	o	o	o	o	o	o	o
18	83100016	Rondella elastica	Spring washer	Rondelle élastique	Federscheibe	2	o	o	o	o	o	o	o
19	19950032	Supporto	Support	Support	Halter	1	o	o	o	o	o	o	o
20	81008192	Vite	Screw	Vis	Schraube	2	o	o	o	o	o	o	o
21	82058011	Dado	Nut	Ecrou	Mutter	2	o	o	o	o	o	o	o
22	83100007	Rondella elastica	Spring washer	Rondelle élastique	Federscheibe	2	o	o	o	o	o	o	o
23	15055059	Profilato	Beading	Garniture	Profilbelag	2	o	o	o	o	o	o	o
24	19955037	Tampone lungo	Long buffer	Tampon long	Langer Gummipuffer	2	o	o	o	o	o	o	o
	19955038	Tampone corto	Short buffer	Tampon court	Kurzer Gummipuffer	2	o	o	o	o	o	o	o
25	19961022	+ Supporto	Support	Support	Halter	1	o		o	o			
26	71670812	+ Grano	Grub	Ergot	Stift	1	o		o	o			
27	15071002	Protezione	Protection	Protection	Schutzkappe	1	o	o	o	o	o	o	o
28	19957005	Molla	Spring	Ressort	Feder	1	o	o	o	o	o	o	o

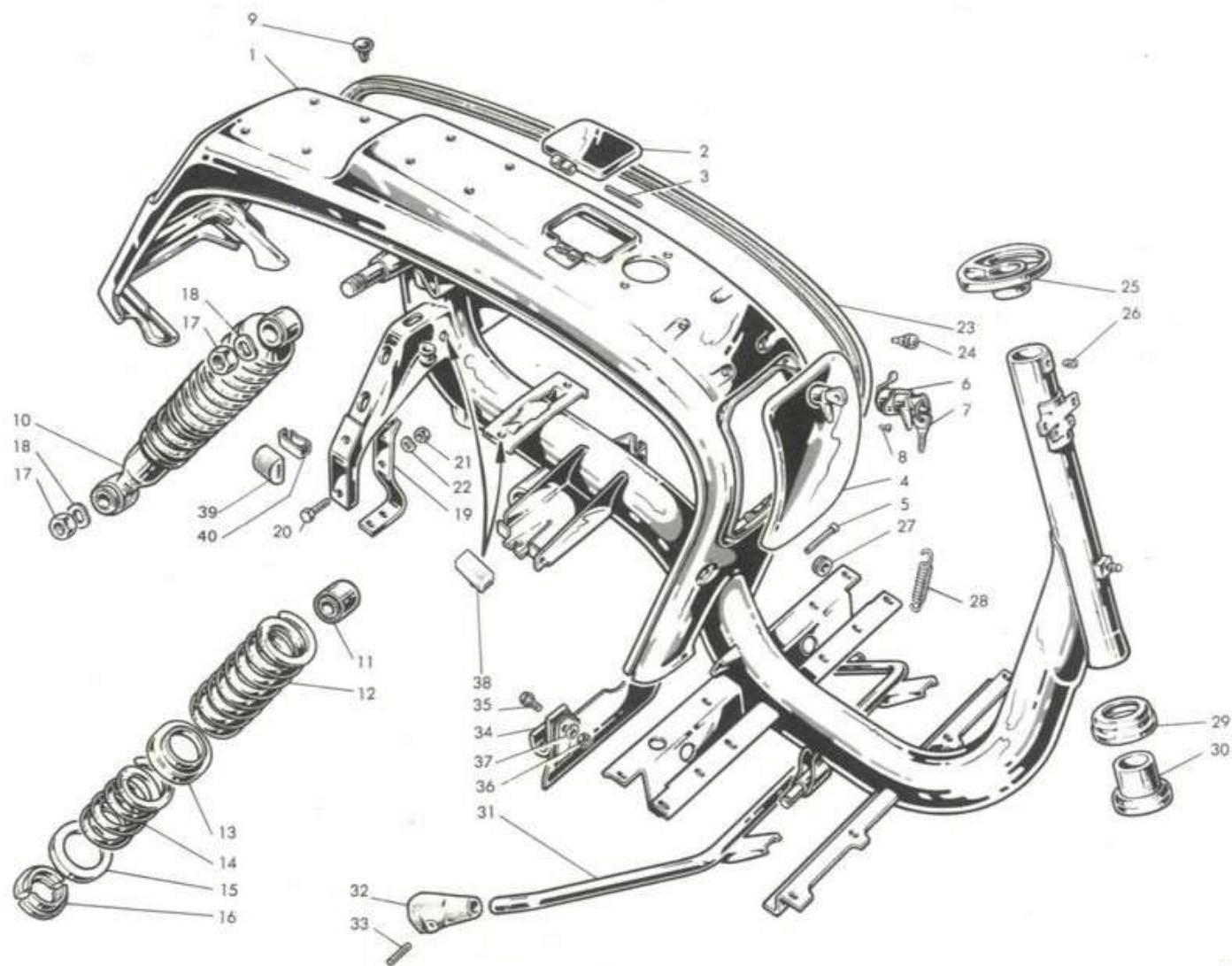

19-066

www.rpvn.it

VII
VIII
IX
X
XI
XII
XIII
XIV
XV
XVI
XVII

Fig. Abb.	Ord. No. Bestell N.	Denominazione	Description	Désignation	Benennung	Qt. Anzahl	125 LI	125 S	150 LI	150 S	150 SX	175 TV	200 SX
29	15061024	Protezione	Protection	Protection	Schutzkappe	1	o	o	o	o	o	o	o
30	19061023	Calotta	Cup	Cuvette	Schale	1	o	o	o	o	o	o	o
31	19957030	Cavalletto con figg. 32-33	Center stand with fig. 32-33	Béquille avec fig. 32-33	Mittelständer mit Abb. 32-33	1	o	o	o	o	o	o	o
32	15057020	Piedino	Rubber cap	Protection	Gummifuss	2	o	o	o	o	o	o	o
33	15057009	Spina	Pin	Axe	Stift	2	o	o	o	o	o	o	o
34	19957040	Supporto	Support	Support	Halter	1	o	o	o	o	o	o	o
35	81008221	Vite	Screw	Vis	Schraube	2	o	o	o	o	o	o	o
36	82108012	Dado	Nut	Ecrou	Mutter	2	o	o	o	o	o	o	o
37	73170084	Rondella elastica	Spring washer	Rondelle élastique	Federscheibe	2	o	o	o	o	o	o	o
38	19950021	Tampone	Buffer	Tampon	Gummipuffer	4	o	o	o	o	o	o	o
39	19950065	Tampone	Buffer	Tampon	Gummipuffer	2	o	o	o	o	o	o	o
40	19950115	Molla	Spring	Ressort	Feder	2	o	o	o	o	o	o	o

✦ Pre-modifica. Pre-modification. Pré-modification. Vor-Aenderung.

✦ Post-modifica. Post-modification. Post-modification. Nach-Aenderung.

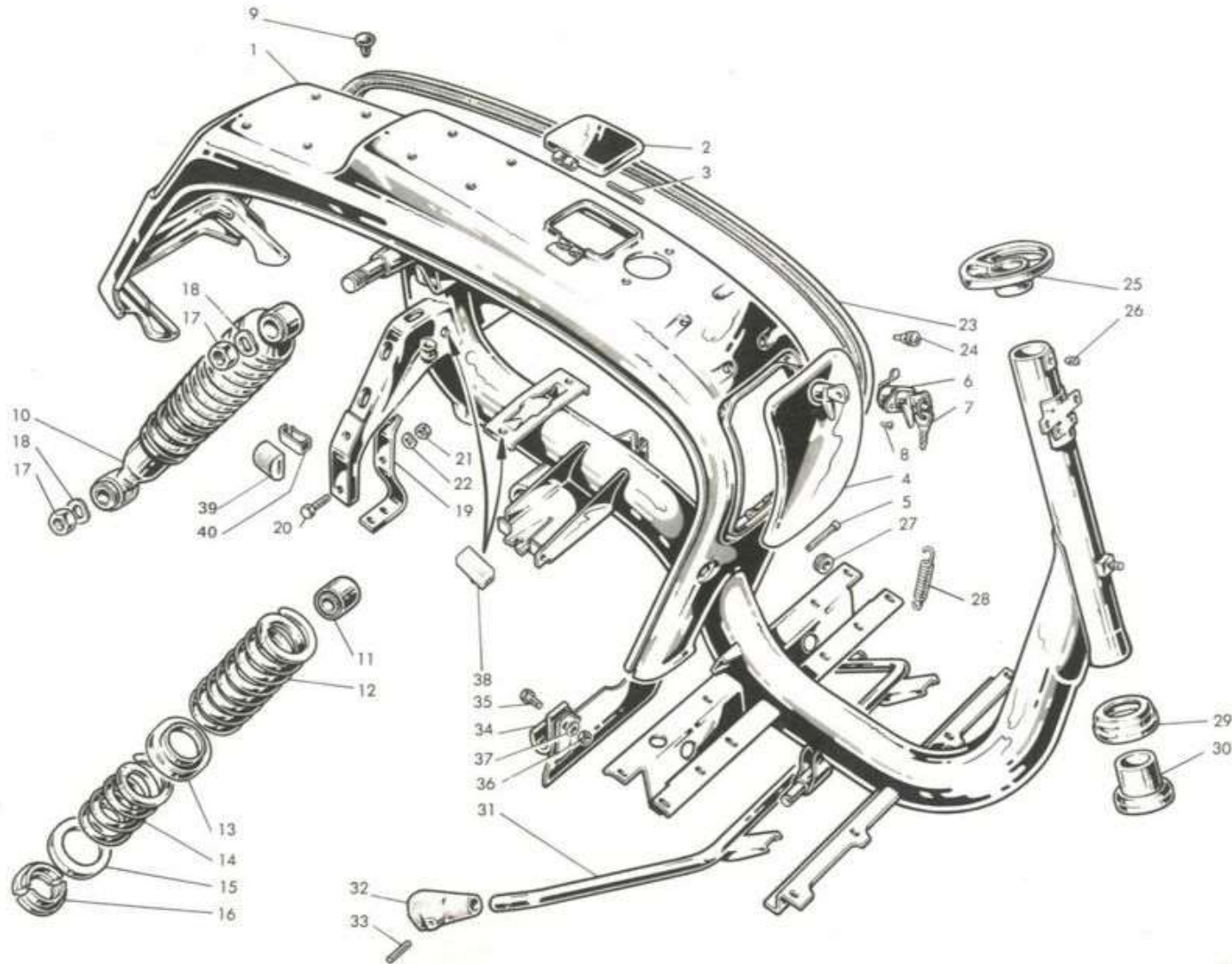

19-066

VIII
IX
X
XI
XII
XIII
XIV
XV
XVI
XVII

www.tp.com

Manubrio Tachimetro Forcella -

Handle bar - Fork - Speedometer

Guidon - Fourche - Compteur

Lenker - Gabel - Tachometer

Tav. VIII

Fig. Abb.	Ord. No. Bestell N.	Denominazione	Description	Désignation	Benennung	Qt. Anzahl	125 LI	125 S	150 LI	150 S	150 SX	175 TV	200 SX
1	19962028	♠ Spina	Pin	Axe	Stift	2	o	o	o	o	o	o	o
2	19962026	♠ Roccia	Bush	Bague	Sprengring	2	o	o	o	o	o	o	o
3	19962022	Soccola	Bush	Bague	Sprengring	2	o	o	o	o	o	o	o
4	19762030	♣ Alberino	Shaft	Arbre	Welle	2				o		o	
	19762080	♠ Alberino	Shaft	Arbre	Welle	2		o		o	o	o	o
	19962030	♣ Alberino	Shaft	Arbre	Welle	2	o		o				
	19962080	♠ Alberino	Shaft	Arbre	Welle	2	o		o				
5	19963005	Rondella	Washer	Rondelle	Scheibe	1	o	o	o	o	o	o	o
6	19963003	Rondella	Washer	Rondelle	Scheibe	1	o	o	o	o	o	o	o
7	19962016	Manopola	Twist grip	Poignée	Griff	2	o	o	o	o	o	o	o
8	71480612	Vite	Screw	Vis	Schraube	2	o	o	o	o	o	o	o
9	19962023	Leva	Lever	Levier	Hebel	1	o	o	o	o	o	o	o
10	15062015	♣ Vite	Screw	Vis	Schraube	2	o		o	o		o	
11	83100005	♣ Rondella	Washer	Rondelle	Scheibe	2	o		o	o		o	
12	19963004	♣ Carrucola	Roller	Curseur	Seilrolle	1	o		o	o		o	
	19963009	♠ Settore	Sector	Secteur	Anpressbügel	1	o	o	o	o	o	o	o
13	15062013	Rondella rasamento spess. 0,4	Shim	Rondelle de réglage	Ausgleichscheibe	2	o	o	o	o	o	o	o
	15062023	Rondella rasamento spess. 0,6	Shim	Rondelle de réglage	Ausgleichscheibe	2	o	o	o	o	o	o	o
14	80600410	Vite	Screw	Vis	Schraube	4	o	o	o	o	o	o	o
15	83100004	Rondella	Washer	Rondelle	Scheibe	4	o	o	o	o	o	o	o
16	19222012	Occhiello	Clip	Agrafe	Haken	2	o	o	o	o	o	o	o
17	15062012	Piastrina	Plate	Plaquette	Aufnahmeblech	2	o	o	o	o	o	o	o
18	19962011	Boccola	Bush	Bague	Sprengring	2	o	o	o	o	o	o	o
19	19963002	♣ Manicotto	Sleeve	Manchon	Muffe	1	o		o	o		o	
	19963008	♠ Manicotto	Sleeve	Manchon	Muffe	1	o	o	o	o	o	o	o
20	19763006	Supporto	Support	Support	Gelenkstück	1		o		o	o	o	o
	19963006	Supporto	Support	Support	Gelenkstück	1	o		o				
21	19062002	Perno	Pin	Axe	Hebelschraube	2	o	o	o	o	o	o	o
22	19062004	Rondella	Washer	Rondelle	Scheibe	2	o	o	o	o	o	o	o
23	19062003	Dado	Nut	Ecrou	Mutter	2	o	o	o	o	o	o	o

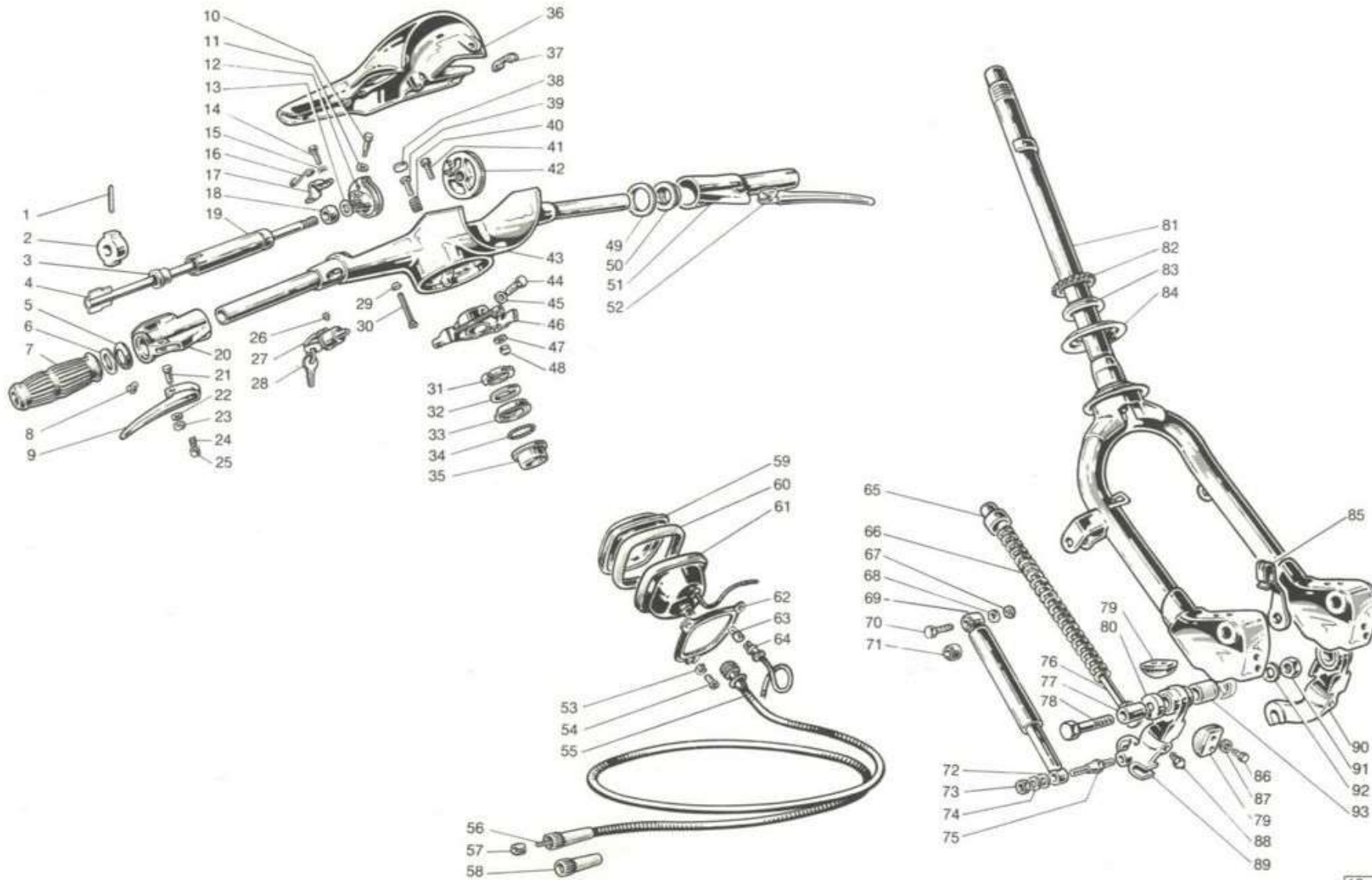

19-067



www.fpv.it

VIII
IX
X
XI
XII
XIII
XIV
XV
XVI
XVII

Fig. Abb.	Ord. No. Bestell N.	Denominazione	Description	Désignation	Benennung	Qt. Anzahl	125 LI	125 S	150 LI	150 S	150 SX	175 TV	200 SX
24	19062021	Molla	Spring	Ressort	Druckfeder	2	o	o	o	o	o	o	o
25	19062019	Pulsante	Push rod	Poussoir	Stößel	2	o	o	o	o	o	o	o
26	15088006	Vite	Screw	Vis	Schraube	1	o	o	o	o	o	o	o
27	19988010	Antifurto con fig. 28	Steering lock with fig. 28	Serrure antivol avec fig. 28	Schloss mit Abb. 28	1	o	o	o	o	o	o	o
28	00205501	Chiave	Key	Clé	Schlüssel	2	o	o	o	o	o	o	o
29	83130005	Rondella	Washer	Rondelle	Scheibe	2	o	o	o	o	o	o	o
30	71450545	Vite	Screw	Vis	Schraube	2	o	o	o	o	o	o	o
31	15061018	Anello registro	Adjustment ring	Anneau réglage	Einstellring	1	o	o	o	o	o	o	o
32	19061025	Rondella sicurezza	Lock washer	Rondelle de sécurité	Sicherungsscheibe	1	o	o	o	o	o	o	o
33	15061019	Calotta	Cup	Cuvette	Schale	1	o	o	o	o	o	o	o
34	15061060	Gabbietta a sfere	Ball race	Cage à billes	Kugelkäfig	1	o	o	o	o	o	o	o
35	15061021	✦ Sede	Ball seat	Siège	Lauftring	1	o		o		o		
	19961026	◇ Sede	Ball seat	Siège	Lauftring	1	o	o	o	o	o	o	o
36	19761020	Calotta	Cover	Couvercle	Deckel	1		o		o	o	o	o
	19961020	Calotta	Cover	Couvercle	Deckel	1	o		o				
37	19961011	Guarnizione	Gasket	Joint	Dichtung	2	o	o	o	o	o	o	o
38	15088003	Dischetto	Disc	Disque	Scheibe	1	o	o	o	o	o	o	o
39	19988001	Piolo	Pin	Pivot	Stift	1	o	o	o	o	o	o	o
40	19988002	Molla	Spring	Ressort	Feder	1	o	o	o	o	o	o	o
41	70300625	Vite	Screw	Vis	Schraube	3	o	o	o	o	o	o	o
42	15062014	✦ Carrucola	Roller	Curseur	Seilrolle	1	o		o	o		o	
	19962027	◇ Carrucola	Roller	Curseur	Seilrolle	1	o	o	o	o	o	o	o
43	19761010	✦ Manubrio	Handle bar	Guidon	Lenker	1				o		o	
	19761030	◇ Manubrio	Handle bar	Guidon	Lenker	1		o		o	o	o	o
	19961010	✦ Manubrio	Handle bar	Guidon	Lenker	1	o		o				
	19961030	◇ Manubrio	Handle bar	Guidon	Lenker	1	o		o				
44	71061035	Vite	Screw	Vis	Schraube	1	o	o	o	o	o	o	o
45	83120010	Rondella elastica	Spring washer	Rondelle élastique	Federscheibe	1	o	o	o	o	o	o	o
46	19961008	Morsetto	Clamp	Etau	Lenkerklemme	1	o	o	o	o	o	o	o
47	83100006	Rondella elastica	Spring washer	Rondelle élastique	Federscheibe	3	o	o	o	o	o	o	o

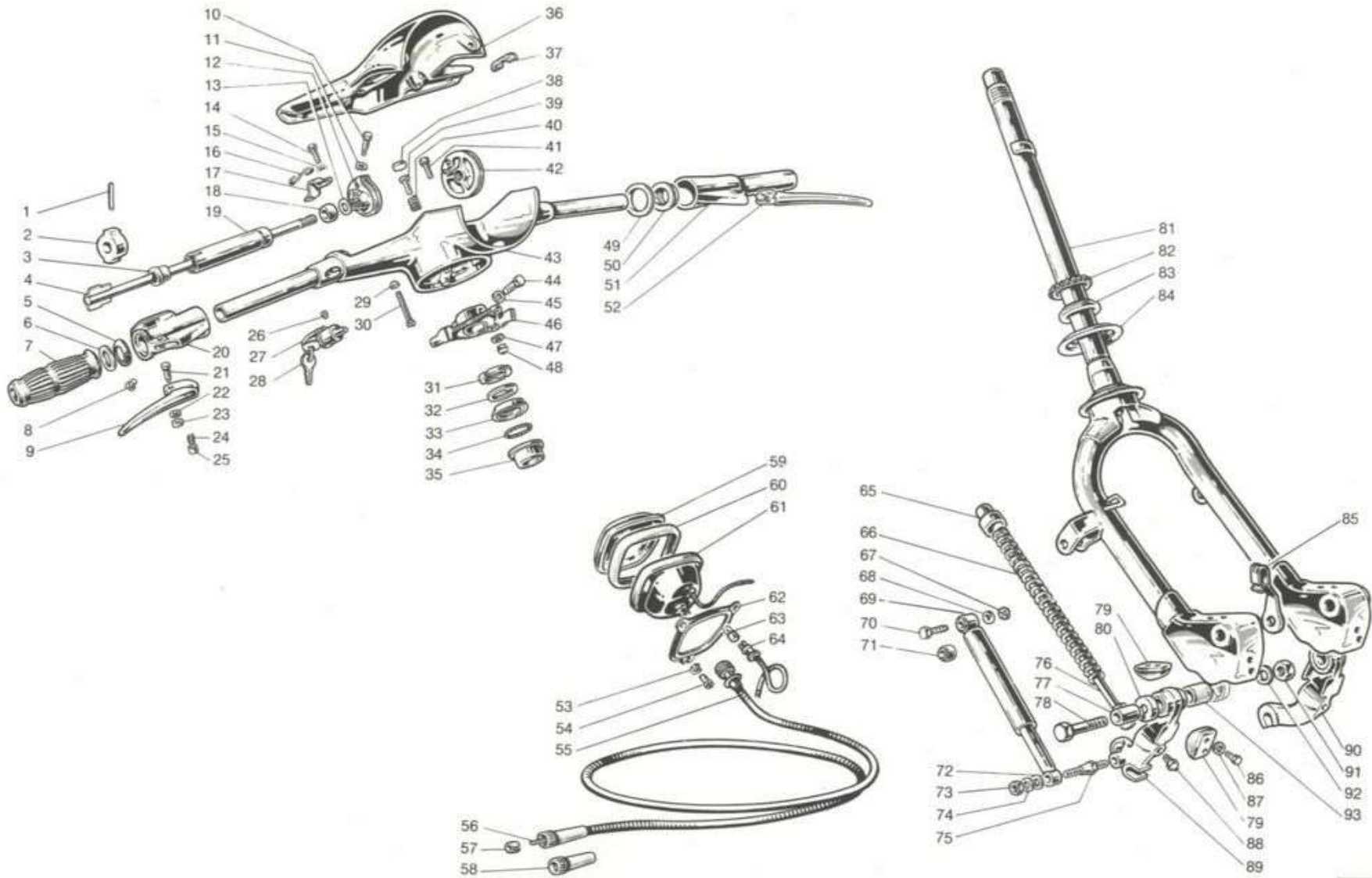

19-067



IX
X
XI
XII
XIII
XIV
XV
XVI
XVII

www.tp.com

Fig. Abb.	Ord. No. Bestell N.	Denominazione	Description	Désignation	Benennung	Qt. Anzahl	125 LI	125 S	150 LI	150 S	150 SX	175 TV	200 SX
48	19061110	Dado per fig. 41	Nut for fig. 41	Ecrou pour fig. 41	Mutter für Abb. 41	3	o	o	o	o	o	o	o
49	19962017	Collareto di rasamento	Collar	Collier	Bördelung	1	o	o	o	o	o	o	o
50	19962006	Boccola	Bush	Bague	Büchse	1	o	o	o	o	o	o	o
51	19962020 †	Supporto	Support	Support	Gelenkstück	1	o		o	o		o	
	19962040 †	Supporto	Support	Support	Gelenkstück	1	o	o	o	o	o	o	o
52	19962023	Leva	Lever	Levier	Hebel	1	o	o	o	o	o	o	o
53	83120003	Rondella elastica	Spring washer	Rondelle élastique	Federscheibe	3	o	o	o	o	o	o	o
54	19987004	Vite	Screw	Vis	Schraube	3	o	o	o	o	o	o	o
55	00611068 †	Trasmissione con fig. 56	Cable with fig. 56	Câble avec fig. 56	Antriebswelle mit Abb. 56	1	o		o			o	
	00611075 †	Trasmissione con fig. 56	Cable with fig. 56	Câble avec fig. 56	Antriebswelle mit Abb. 56	1	o	o	o	o	o	o	o
56	00611039 †	Flessibile	Inner cable	Câble intérieur	Biessame Welle	1	o		o			o	
	00611076 †	Flessibile	Inner cable	Câble intérieur	Biessame Welle	1	o	o	o	o	o	o	o
57	00611041	Bussola	Bush	Bague	Büchse	1	o	o	o	o	o	o	o
58	00611040	Ghiera	Ring	Bague	Einstellmutter	1	o	o	o	o	o	o	o
59	00611065	Coperchietto trasparente	Transparent cover	Verre de compteur	Deckel		o	o	o	o	o	o	o
60	00611066	Guarnizione	Gasket	Joint	Dichtung	1	o	o	o	o	o	o	o
61	00611061 †	Contachilometri	Speedometer (Km)	Compteur (Km)	Tachometer (Km)	1			o				
	00611062 †	Contamiglia	Speedometer (Miles)	Compteur (Milles)	Tachometer (Meilen)	1			o				
	00611063 †	Contachilometri	Speedometer (Km)	Compteur (Km)	Tachometer (Km)	1	o						
	00611064 †	Contamiglia	Speedometer (Miles)	Compteur (Milles)	Tachometer (Meilen)	1	o						
	00611069 †	Contachilometri	Speedometer (Km)	Compteur (Km)	Tachometer (Km)	1		o	o				
	00611070 †	Contamiglia	Speedometer (Miles)	Compteur (Milles)	Tachometer (Meilen)	1		o	o				
	00611071 †	Contachilometri	Speedometer (Km)	Compteur (Km)	Tachometer (Km)	1	o						
	00611072 †	Contamiglia	Speedometer (Miles)	Compteur (Milles)	Tachometer (Meilen)	1	o						
	00611073 †	Contachilometri	Speedometer (Km)	Compteur (Km)	Tachometer (Km)	1				o	o	o	
	00611074 †	Contamiglia	Speedometer (Miles)	Compteur (Milles)	Tachometer (Meilen)	1				o	o	o	
	00611096	Contachilometri	Speedometer (Km)	Compteur (Km)	Tachometer (Km)	1							o
	00611097	Contamiglia	Speedometer (Miles)	Compteur (Milles)	Tachometer (Meilen)	1							o
	62	19987001	Flangia	Flange	Bride	Flansch	1	o	o	o	o	o	o
63	87520300	Lampadina 12 V. 3 W.	Bulb 12 V. 3 W.	Ampoule 12 V. 3 W.	Glühlampe 12 V. 3 W.	1	o	o	o	o	o	o	o

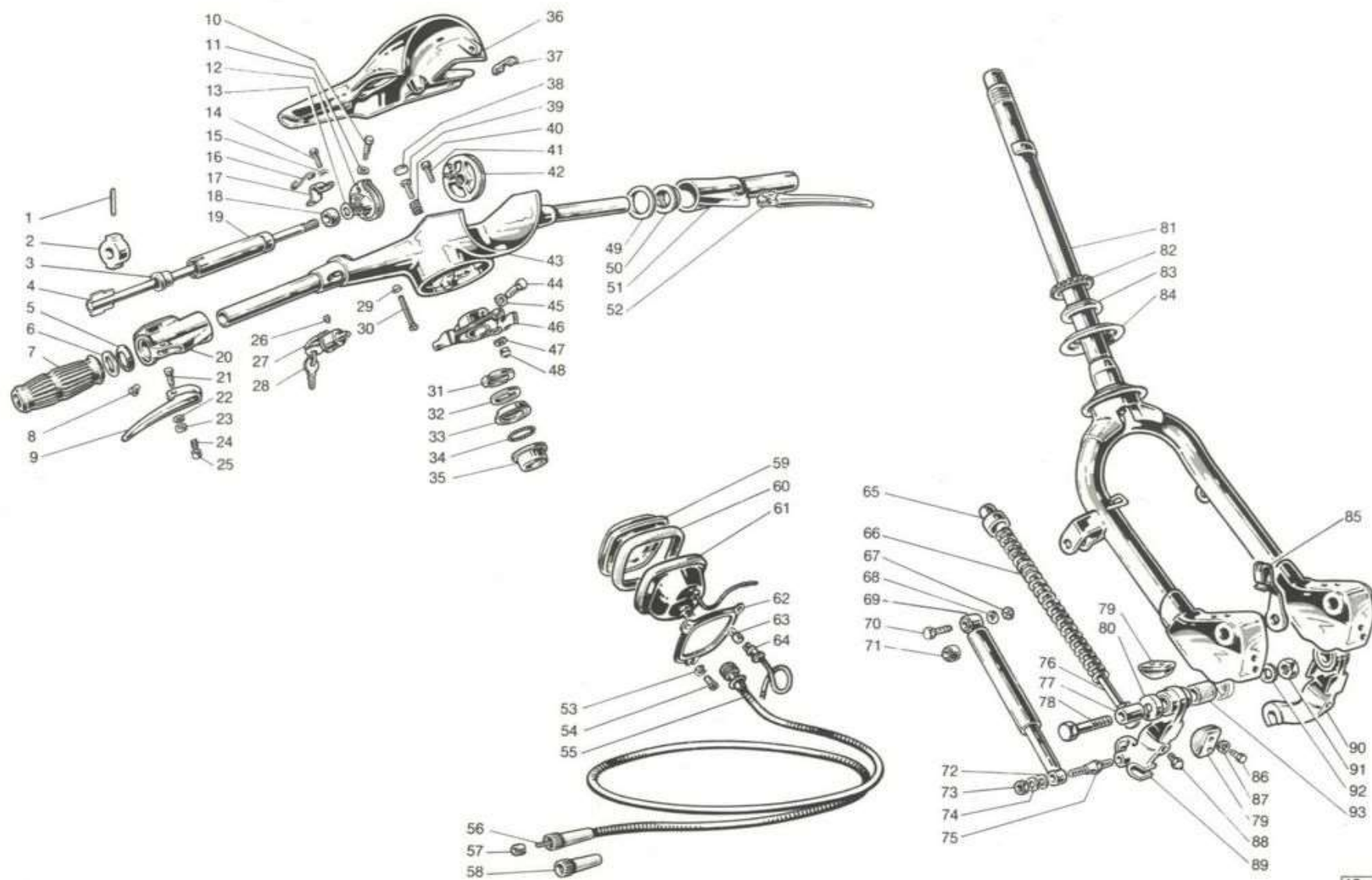

19-067



www.rpv.it

IX
X
XI
XII
XIII
XIV
XV
XVI
XVII

Fig. Abb.	Ord. No. Bestell N.	Denominazione	Description	Désignation	Benennung	Qt. Anzahl	125 LI	125 S	150 LI	150 S	150 SX	175 TV	200 SX
64	00611015	Portalampada	Bulb socket	Douille de lampe	Lampenfassung	1	o	o	o	o	o	o	o
65	19960027	Bussola	Bush	Bague	Büchse	2	o	o	o	o	o	o	o
66	19060021	Molla	Spring	Ressort	Schraubenfeder	2	o	o	o	o	o	o	o
67	82250060	Dado	Nut	Ecrou	Mutter	2						o	o
68	83120006	Rondella elastica	Spring washer	Rondelle élastique	Federscheibe	2						o	o
69	19060290	Ammortizzatore	Shock absorber	Amortisseur	Stossdämpfer	2						o	o
70	70330630	Vite	Screw	Vis	Schraube	2						o	o
71	19060280	Silentbloc	Silentblock	Silentbloc	Silentblock	4						o	o
72	83020605	Rondella piana	Plain washer	Rondelle plate	Unterlegscheibe	2						o	o
73	82108010	Dado	Nut	Ecrou	Mutter	2						o	o
74	83120006	Rondella elastica	Spring washer	Rondelle élastique	Federscheibe	2						o	o
75	15060032	Perno	Pin	Pivot	Bolzen	2						o	o
76	19060090	Pistoncino	Piston	Piston	Federführungsstange	2	o	o	o	o	o	o	o
77	19060015	Perno	Pin	Pivot	Bolzen	2	o	o	o	o	o	o	o
78	19060016	Vite	Screw	Vis	Schraube	2	o	o	o	o	o	o	o
79	15060070	Tampone	Buffer	Tampon	Gummipuffer	4	o	o	o	o			
	15060070	Tampone	Buffer	Tampon	Gummipuffer	2						o	o
	19760100	Tampone	Buffer	Tampon	Gummipuffer	2						o	o
80	19060017	Coppetta	Cap	Cuvette	Kappe	4	o	o	o	o	o	o	o
81	19760010	Forcella	Fork	Fourche	Gabel	1						o	o
	19960010	Forcella	Fork	Fourche	Gabel	1	o	o	o	o	o		
82	15060020	Gabbietta	Ball race	Cage à billes	Kugelkäfig	1	o	o	o	o	o	o	o
83	19060028	Sede	Ball seat	Siège	Laufring	1	o	o	o	o	o	o	o
84	19960029	Protezione	Protection	Protection	Schutzkappe	1	o	o	o	o	o	o	o
85	19960031	Passaguaina	Retainer	Passe-câble	Kabelführung	1	o	o	o	o	o	o	o
86	81008157	Vite	Screw	Vis	Schraube	8	o	o	o	o	o	o	o
87	83120006	Rondella elastica	Spring washer	Rondelle élastique	Federscheibe	8	o	o	o	o	o	o	o
88	87020006	Ingrassatore	Lubricator	Graisneur	Schmiernippel	2	o	o	o	o	o	o	o
89	19760060	Leva destra con fig. 93	R.H. Lever with fig. 93	Levier droit avec fig. 93	Schwinghebel, r. mit Abb. 93	1						o	o
	19960060	Leva destra con fig. 93	R.H. Lever with fig. 93	Levier droit avec fig. 93	Schwinghebel, r. mit Abb. 93	1	o	o	o				

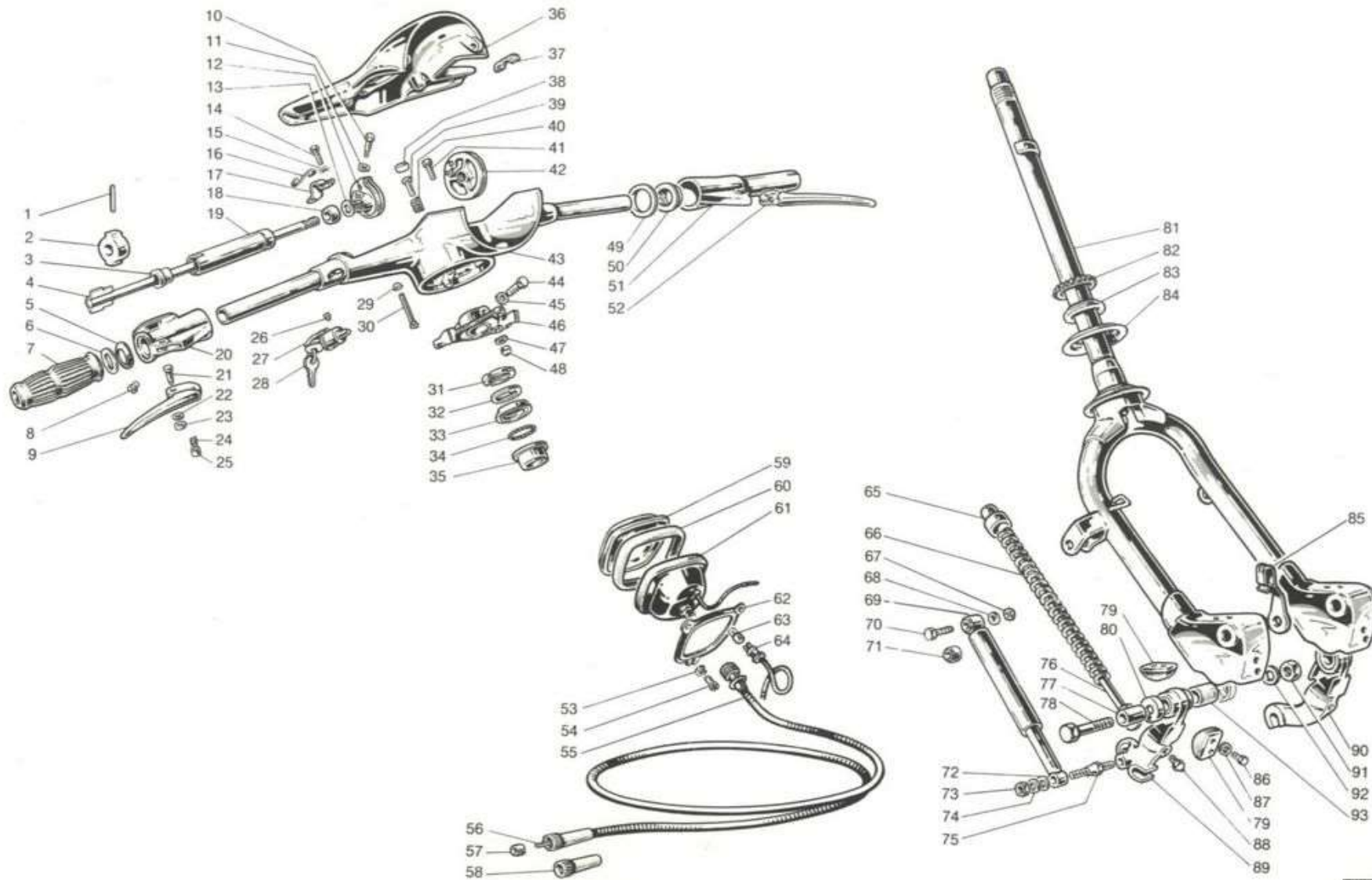

19-067



www.rpv.it

IX
X
XI
XII
XIII
XIV
XV
XVI
XVII

Manubrio - Forcella -
Tachimetro

Handle bar - Fork -
Speedometer

Guidon - Fourche
Compteur

Lenker - Gabel - Tachometer

Tav. VIII

Fig. Abb.	Ord. No. Bestell N.	Denominazione	Description	Désignation	Benennung	Qt. Anzahl	125 LI	125 S	150 LI	150 S	150 SX	175 TV	200 SX
90	19760050	Leva sin. con fig. 93	R.H. Lever with fig. 93	Levier gauche avec fig. 93	Schwinghebel, l. mit Abb. 93	1						0	0
	19960050	Leva sin. con fig. 93	R.H. Lever with fig. 93	Levier gauche avec fig. 93	Schwinghebel, l. mit Abb. 93	1	0	0	0	0	0		
91	82118015	Dado	Nut	Ecrou	Mutter	2	0	0	0	0	0	0	0
92	83120012	Rondella elastica	Spring washer	Rondelle élastique	Federscheibe	1	0	0	0	0	0	0	0
93	19060014	Bussola	Bush	Bague	Büchse	2	0	0	0	0	0	0	0

✦ Pre-modifica. Pre-modification. Pré-modification. Vor-Aenderung.

✦ Post-modifica. Post-modification. Post-modification Nach-Aenderung.

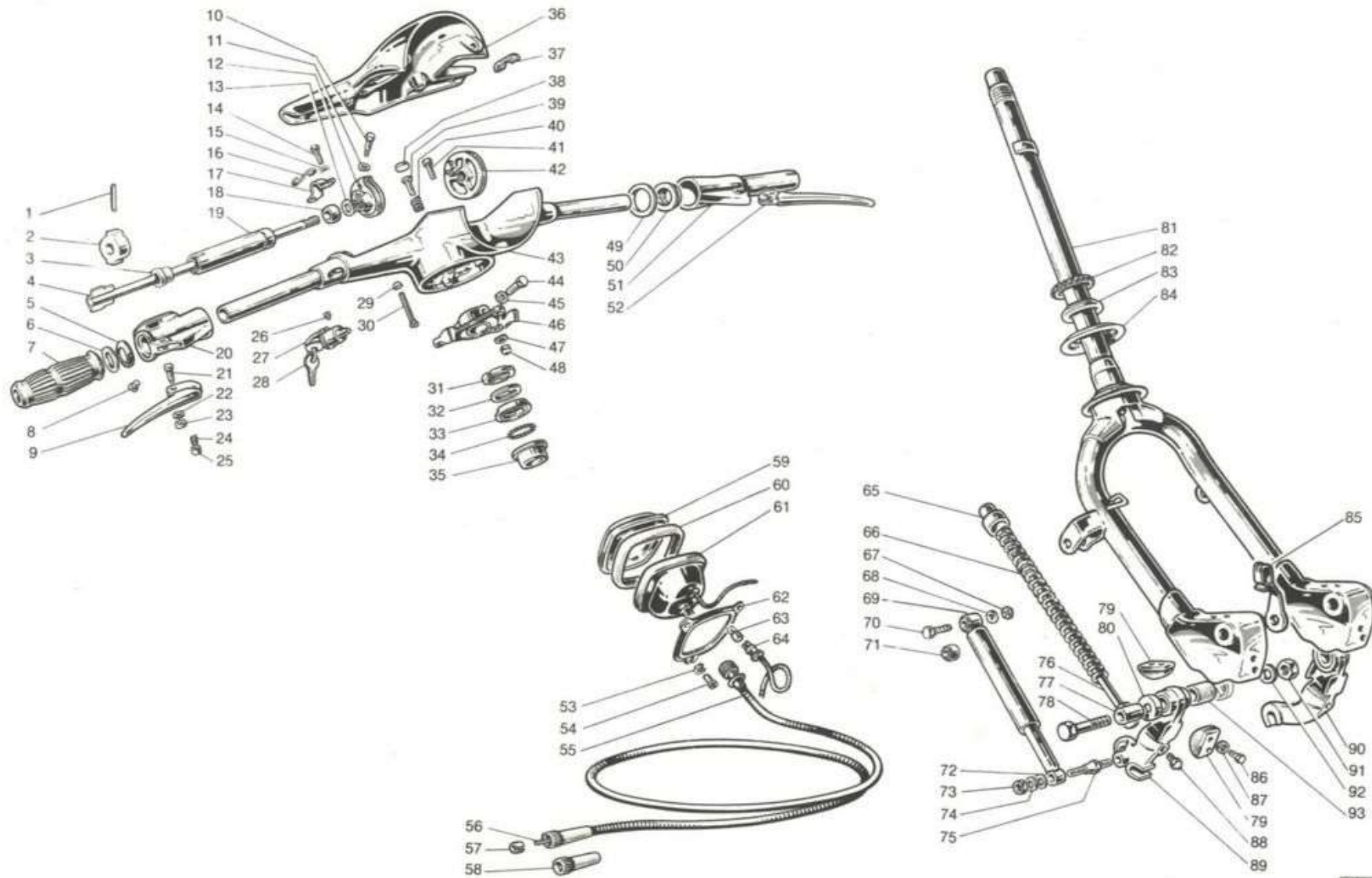

19-067

www.rpv.it

IX
X
XI
XII
XIII
XIV
XV
XVI
XVII

Fig. Abb.	Ord. No. Bestell N.	Denominazione	Description	Désignation	Benennung	Qt. Anzahl	125 LI	125 S	150 LI	150 S	180 SX	175 TV	200 SX
1	19945110	Mozzo posteriore	Rear hub	Moyeu arriere	Hinternabe	1	o	o	o	o	o	o	o
2	15044040	Ceppo con figg. 10-11	Brake shoe with fig. 10-11	Mâchoire avec fig. 10-11	Bremsbacke mit Abb. 10-11	2	o	o	o	o	o	o	o
3	19045003	Cono	Cone	Cône	Kegelbüchse	1	o	o	o	o	o	o	o
4	15044023	Molla	Spring	Ressort	Feder	1	o	o	o	o	o	o	o
5	19031015	Rondella	Washer	Rondelle	Scheibe	2	o	o	o	o	o	o	o
6	19045004	Camma	Cam	Came	Bremsnocken	1	o	o	o	o	o	o	o
7	19059021	Anello di tenuta	Oil seal	Joint d'étanchéité	Dichtring	1	o	o	o	o	o	o	o
8	19059019	Leva	Lever	Levier	Hebel	1	o	o	o	o	o	o	o
9	73260010	Anello elastico	Circlip	Circlip	Seegerring	1	o	o	o	o	o	o	o
10	15044024	Guarnizione	Lining	Garniture	Bremsbelag	2	o	o	o	o	o	o	o
11	15044038	Chiodini	Rivet	Rivet	Niet	8	o	o	o	o	o	o	o
12	87020006	Ingrassatore	Lubricator	Graisser	Schmiernippel	1	o	o	o	o	o	o	o
13	19044140	Disco	Disc	Plateau	Bremsscheibe	1	o	o	o	o	o		
14	15044019	Rondella	Washer	Rondelle	Scheibe	1	o	o	o	o	o		
15	15044017	Leva	Lever	Levier	Hebel	1	o	o	o	o	o		
16	15044070	Dado	Nut	Ecrou	Mutter	1	o	o	o	o	o		
17	15044014	Rondella	Washer	Rondelle	Scheibe	1	o	o	o	o	o		
18	73260010	Anello elastico	Circlip	Circlip	Seegerring	1	o	o	o	o	o		
19	82118015	Dado	Nut	Ecrou	Mutter	1	o	o	o	o	o		
20	19044013	Rondella	Washer	Rondelle	Schraube	1	o	o	o	o	o		
21	19044004	Perno	Axle	Axe	Achse	1	o	o	o	o	o		
22	87020006	✦ Ingrassatore	Lubricator	Graisser	Schmiernippel	1	o	o	o	o	o		
23	19045005	Rondella distanziale	Distance washer	Rondelle d'épaisseur	Abstandscheibe	1	o	o	o	o	o	o	o
24	73260012	Anello elastico	Circlip	Circlip	Seegerring	2	o	o	o	o	o	o	o
25	15044044	Piastrina elastica	Spring plate	Plaquette élastique	Federblech	1	o	o	o	o	o	o	o
26	15044022	Piastrina	Plate	Plaquette	Blech	1	o	o	o	o	o	o	o
27	15044038	Chiodini	Rivet	Rivet	Niet	8	o	o	o	o	o	o	o
28	15044024	Guarnizione	Lining	Garniture	Bremsbelag	2	o	o	o	o	o	o	o
29	19044050	Camma	Cam	Came	Bremsnocken	1	o	o	o	o	o	o	o
30	15044018	Rondella	Washer	Rondelle	Scheibe	1	o	o	o	o	o	o	o

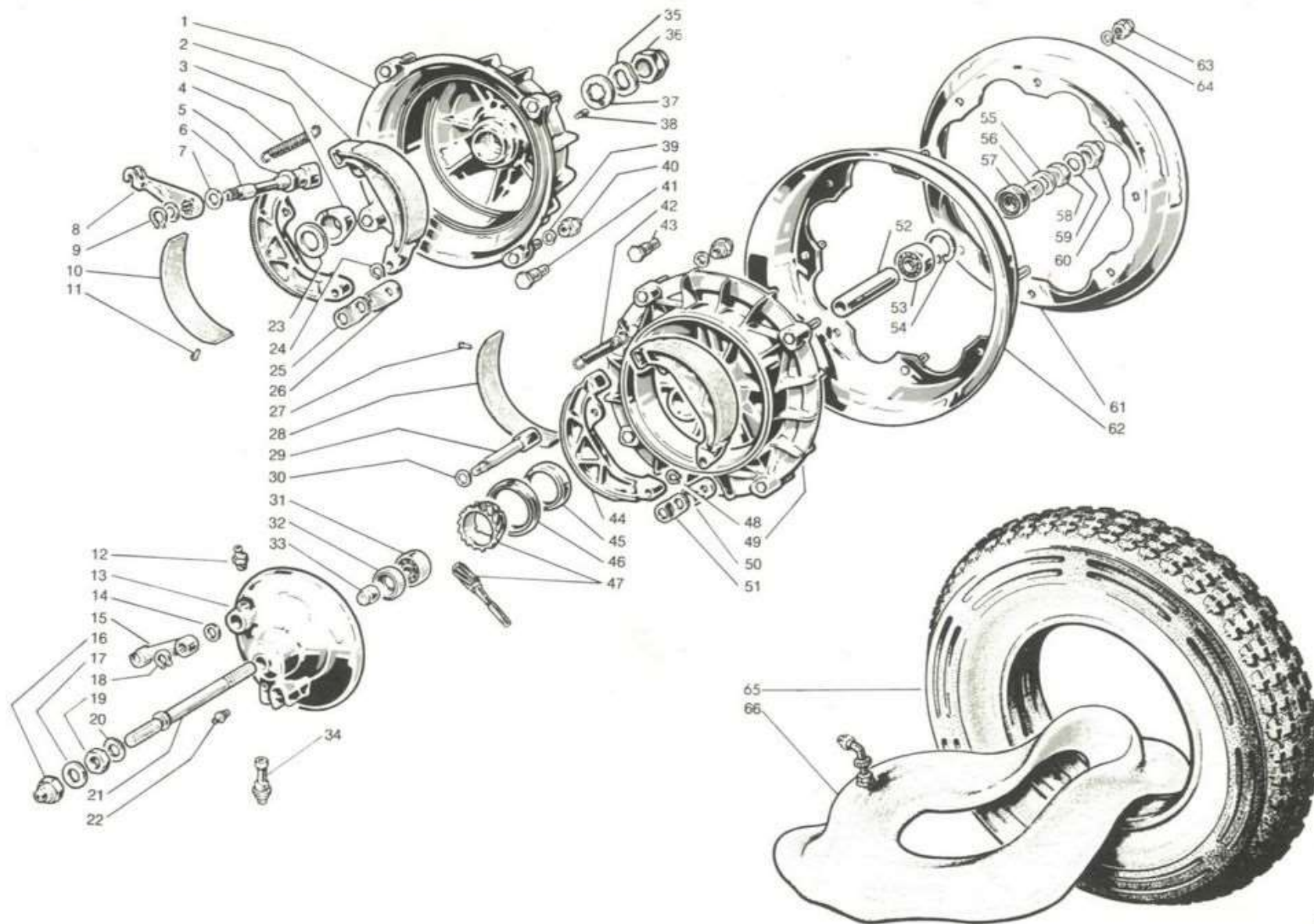

19 - 068



www.rpv.it

IX
X
XI
XII
XIII
XIV
XV
XVI
XVII

Fig. Abb.	Ord. No. Bestell N.	Denominazione	Description	Désignation	Benennung	Qt. Anzahl	125 LI	125 S	150 LI	150 S	150 SX	175 TV	200 SX
31	15044005	Cuscinetto a sfere	Ball bearing	Roulement	Kugellager	1	o	o	o	o	o		
32	15044011	Anello di tenuta	Oil seal	Joint d'étanchéité	Dichtring	1	o	o	o	o	o		
33	15044007	Distanziale	Distance piece	Entretoise	Abstandstück	1	o	o	o	o	o		
34	00611044	Bussola tachimetro	Bush for speedometer	Bague pour compteur	Büchse für Tachometer	1	o	o	o	o	o		
35	19045013	Rondella elastica	Spring washer	Rondelle élastique	Federscheibe	1	o	o	o	o	o	o	o
36	19045060	Dado	Nut	Ecrou	Mutter	1	o	o	o	o	o	o	o
37	19045014	Rondella sicurezza	Lock washer	Rondelle sécurité	Sicherungsscheibe	1	o	o	o	o	o	o	o
38	19045015	Vite	Screw	Vis	Schraube	1	o	o	o	o	o	o	o
39	83100008	Rondella elastica	Spring washer	Rondelle élastique	Federscheibe	8	o	o	o	o	o	o	o
40	15044110	Dado	Nut	Ecrou	Mutter	8	o	o	o	o	o	o	o
41	19044002	Prigioniero	Stud	Goujon	Stiftschraube	4	o	o	o	o	o	o	o
42	15044023	Molla ceppi	Spring for brake shoes	Ressort pour mâchoires	Feder für Bremsbacken	1	o	o	o	o	o		
43	19044002	Prigioniero	Stud	Goujon	Stiftschraube	4	o	o	o	o	o		
44	15044040	Ceppo	Brake shoe	Mâchoire	Bremsbacke	2	o	o	o	o	o		
45	15044041	Bussola	Bush	Bague	Büchse	1	o	o	o	o	o		
46	15044028	Anello di tenuta	Oil seal	Anneau d'étanchéité	Dichtring	1	o	o	o	o	o		
47	00611058	Rinvio tachimetro	Speedometer drive	Renvoi de compteur	Tachometerantrieb	1	o	o	o	o	o		
48	73260012	Anello elastico	Circlip	Circlip	Seegerring	2	o	o	o	o	o		
49	19944160	Mozzo anteriore	Front hub	Moyeu avant	Vordernabe	1	o	o	o	o	o		
50	15044022	Piastrina	Plate	Plaquette	Blech	1	o	o	o	o	o		
51	15044044	Piastrina elastica	Spring plate	Plaquette élastique	Federblech	1	o	o	o	o	o		
52	15044006	Distanziale	Distance piece	Entretoise	Abstandrohr	1	o	o	o	o	o		
53	15044005	Cuscinetto	Ball bearing	Roulement	Kugellager	1	o	o	o	o	o		
54	73250032	Anello elastico	Circlip	Circlip	Seegerring	1	o	o	o	o	o		
55	19544009	Rondella	Washer	Rondelle	Scheibe	1	o	o	o	o	o		
56	15044007	Distanziale	Distance piece	Entretoise	Abstandrohr	1	o	o	o	o	o		
57	15044011	Anello di tenuta	Oil seal	Joint d'étanchéité	Dichtring	1	o	o	o	o	o		
58	82118015	Dado	Nut	Ecrou	Mutter	1	o	o	o	o	o		
59	15044014	Rondella	Washer	Rondelle	Scheibe	1	o	o	o	o	o		
60	15044070	Dado	Nut	Ecrou	Mutter	1	o	o	o	o	o		

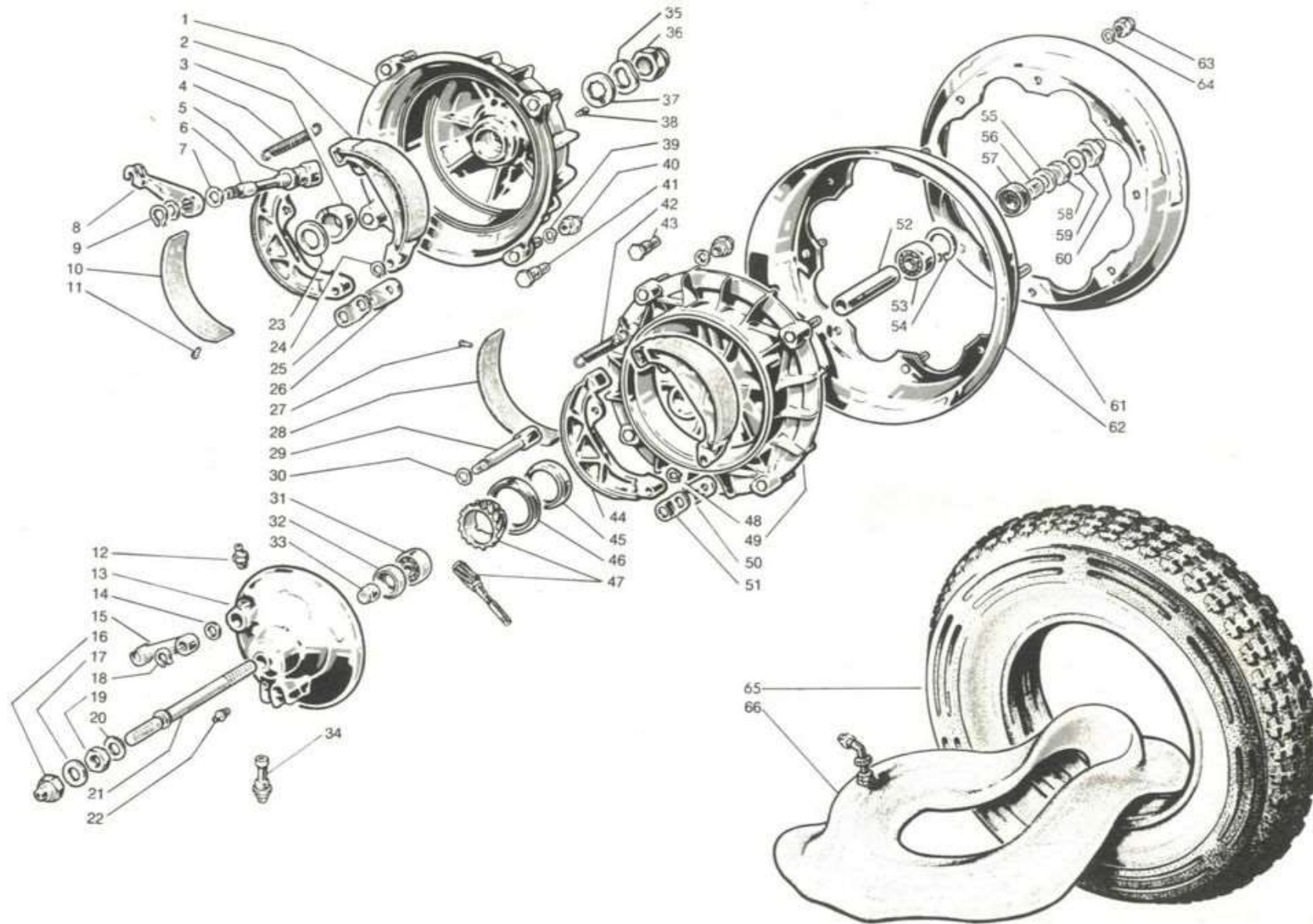

19 - 068



X

XI

XII

XIII

XIV

XV

XVI

XVI

www.rpv.it

Fig. Abb.	Ord. No. Bestell N.	Denominazione	Description	Désignation	Benennung	Qt. Anzahl	125 LI	125 S	150 LI	150 S	150 SX	175 TV	200 SX
61	19044034	Cerchione sinistro	Rim L.H.	Jante G.	Felge links	2	○	○	○	○	○		
62	19044060	Cerchione destro	Rim R.H.	Jante D.	Felge rechts	2	○	○	○	○	○		
63	15044100	Dado	Nut	Ecrou	Mutter	8	○	○	○	○	○		
64	83100008	Rondella elastica	Spring washer	Rondelle élastique	Federscheibe	8	○	○	○	○	○		
65	15044036	Copertura 3,5" x 10"	Tyre 3,5" x 10"	Pneu 3,5" x 10"	Reifen 3,5" x 10"	2	○	○	○	○	○	○	○
66	19044037	Camera d'aria 3,5" x 10"	Inner tube 3,5" x 10"	Chambre à air 3,5" x 10"	Schlauch 3,5" x 10"	2	○	○	○	○	○	○	○

✦ Pre-modifica. Pre-modification. Pré-modification. Vor-Aenderung.

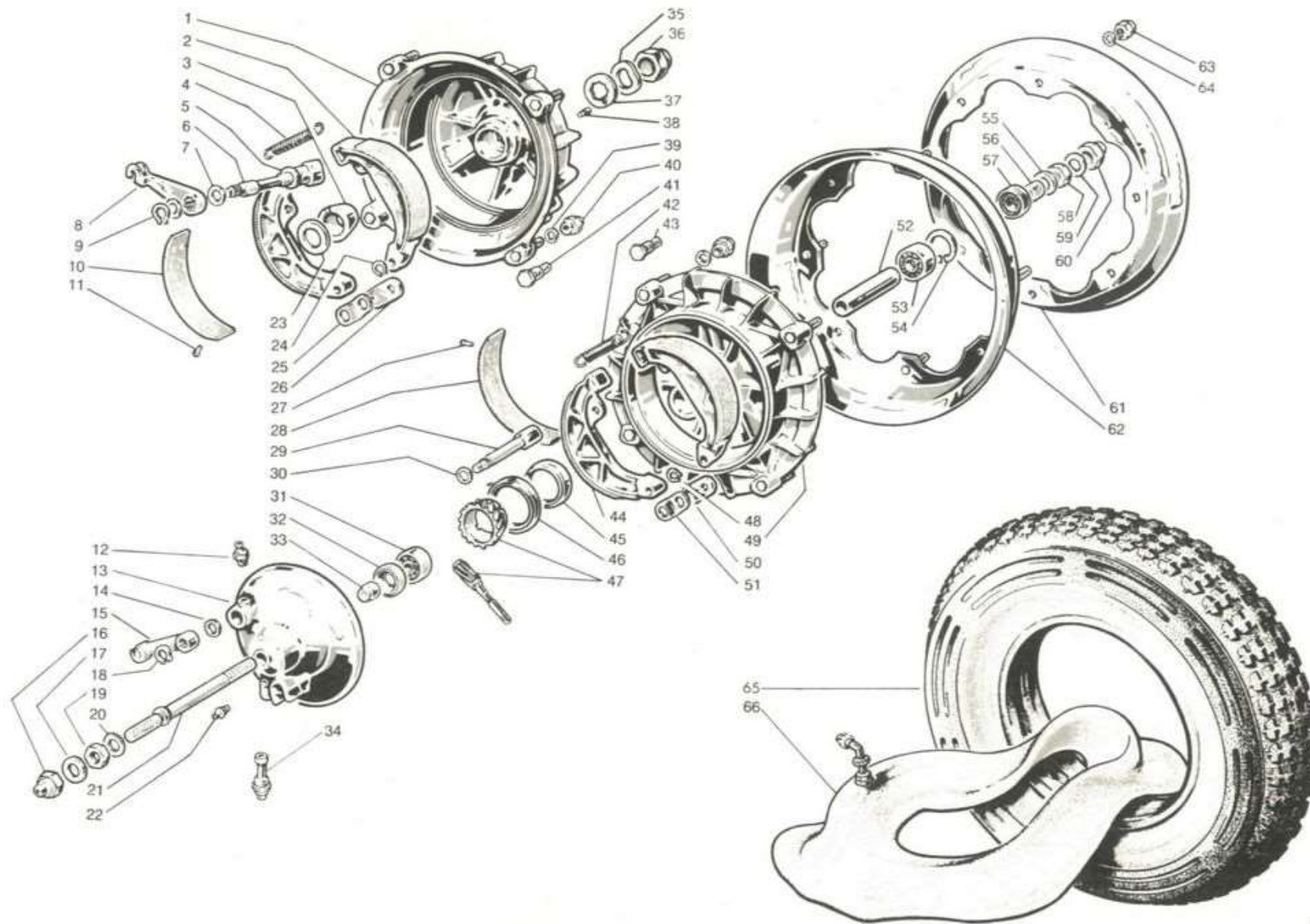

19 - 068

INNOCENTI

X
XI
XII
XIII
XIV
XV
XVI
XVII

www.tprv.it

Fig. Abb.	Ord. No. Bestell N.	Denominazione	Description	Désignation	Benennung	Qt. Anzahl	125 LI	125 S	150 LI	150 S	150 SX	175 TV	200 SX
1	19744180	Cuscinetto reggispinta	Thrust bearing	Roulement poussant	Drucklager	1						0	0
2	19744056	Dischetto	Disc	Disque	Scheibe	1						0	0
3	19744066	Anello elastico	Circlip	Circlip	Seegerring	1						0	0
4	19744058	Molla	Spring	Ressort	Feder	1						0	0
5	19744057	Rondella	Washer	Rondelle	Scheibe	1						0	0
6	19744064	Cappello	Cap	Chapeau	Kappe	1						0	0
7	19744055	Perno	Pin	Pivot	Bolzen	1						0	0
8	19744054	Camma	Cam	Came	Nocken	1						0	0
9	78920516	Sfera	Ball	Bille	Kugel	3						0	0
10	19744190	Leva freno	Brake lever	Levier de frein	Bremshebel	1						0	0
11	19744170	Coperchio con fig. 13-20	Cover with fig. 13-20	Couvercle avec fig. 13-20	Deckel mit Abb. 13-20	1						0	0
12	19744200	Disco con pastiglia	Disc with pad	Disque avec tablette	Scheibe mit Platte	2						0	0
13	87020006	Ingrassatore	Grease nipple	Graisseur	Schmiernippel	1						0	0
14	15044004	Perno ruota	Wheel axle	Axe de roue	Radachse	1						0	0
15	15044014	Rondella	Washer	Rondelle	Unterlegscheibe	1						0	0
16	15044070	Dado	Nut	Ecrou	Mutter	1						0	0
17	19744051	Disco frenante	Braking disc	Disque freinant	Bremsscheibe	1						0	0
18	15044028	Anello di tenuta	Oil seal	Joint d'étanchéité	Dichtring	1						0	0
19	00611044	Bussola tachimetro	Speedometer bush	Bague du compteur	Tachometerbüchse	1						0	0
20	15044015	Prigioniero	Stud	Goujon	Stiftschraube	1						0	0
21	15044070	Dado	Nut	Ecrou	Mutter	1						0	0
22	15044014	Rondella	Washer	Rondelle	Unterlegscheibe	1						0	0
23	19744072	Vite di regolazione	Adjusting screw	Vis de réglage	Einstellschraube	1						0	0
24	82058012	Dado	Nut	Ecrou	Mutter	1						0	0
25	19744160 *	Mozzo	Hub	Moyeu	Nabe	1						0	0
26	15044005	Cuscinetto	Bearing	Roulement	Kugellager	1						0	0
27	15044011	Anello di tenuta	Oil seal	Joint d'étanchéité	Dichtring	1						0	0
28	19744053	Distanziale	Distance piece	Entretoise	Abstandrohr	1						0	0
29	00611058	Rinvio tachimetro	Speedometer drive	Renvoi de compteur	Tachometerantrieb	1						0	0
30	19744049	Dischetto	Disc	Disque	Scheibe	3						0	0

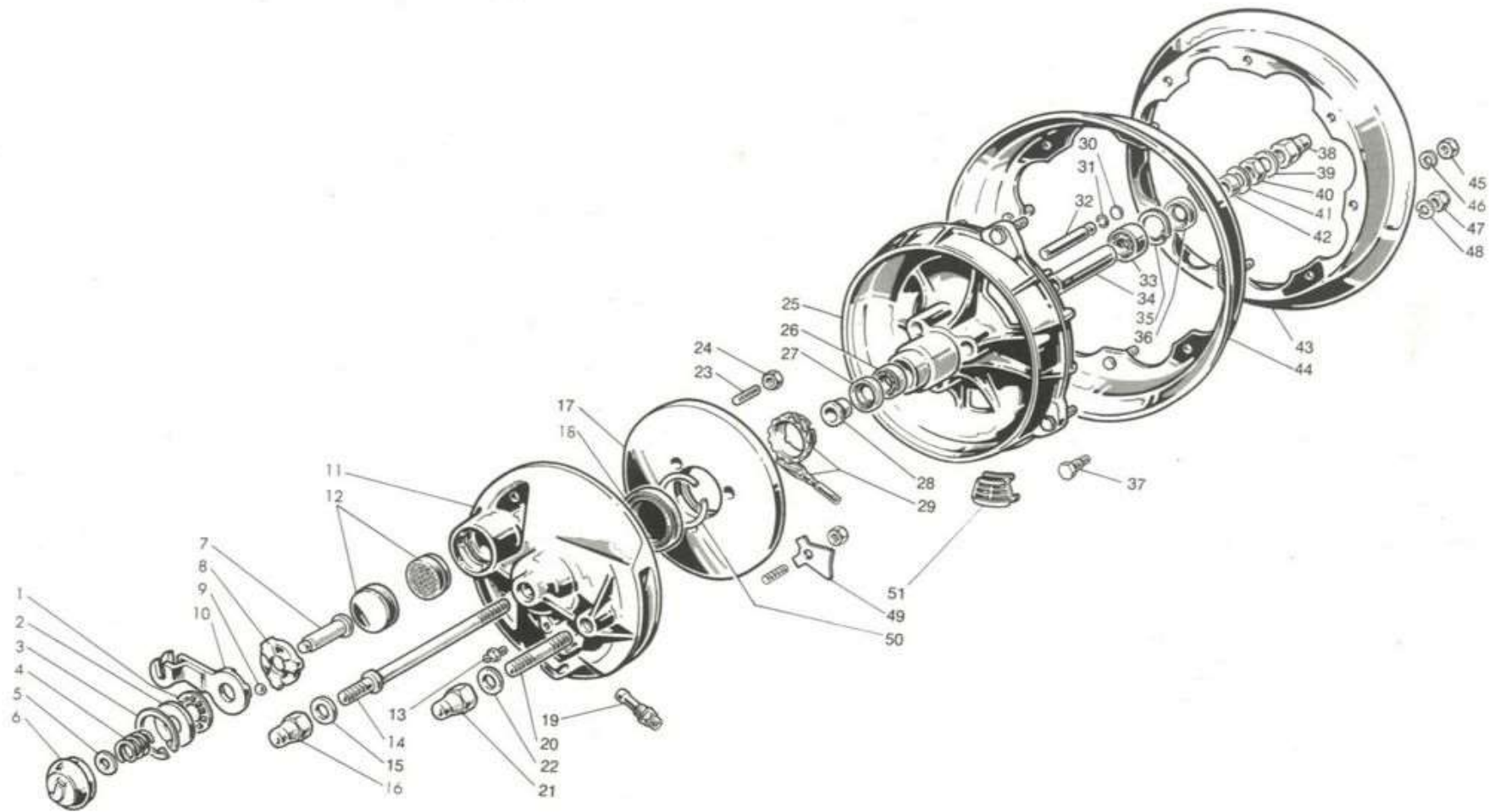

19-069



www.rpv.it

X
XI
XII
XIII
XIV
XV
XVI
XVII

Fig. Abb.	Ord. No. Bestell N.	Denominazione	Description	Désignation	Benennung	Qt. Anzahl	125 LI	125 S	150 LI	150 S	150 SX	175 TV	200 SX
31	19744048	Anello elastico	Circlip	Circlip	Seegerring	3						0	0
32	19744047	Perno	Pin	Pivot	Bolzen	3						0	0
33	15044005	Cuscinetto	Bearing	Roulement	Kugellager	1						0	0
34	15044006	Distanziale	Distance piece	Entretoise	Abstandrohr	1						0	0
35	73250032	Anello elastico	Circlip	Circlip	Seegerring	1						0	0
36	15044011	Anello di tenuta	Oil seal	Joint d'étanchéité	Dichtring	1						0	0
37	19044002	Prigioniero	Stud.	Goujon	Stiftschraube	4						0	0
38	15044070	Dado	Nut	Ecrou	Mutter	1						0	0
39	15044014	Rondella	Washer	Rondelle	Unterlegscheibe	1						0	0
40	82118015	Dado	Nut	Ecrou	Mutter	1						0	0
41	19544009	Rondella	Washer	Rondelle	Scheibe	1						0	0
42	15044007	Distanziale	Distance piece	Entretoise	Abstandrohr	1						0	0
43	19044034	Cerchione sinistro	Rim L.H.	Jante gauche	Felge links	1						0	0
44	19044060	Cerchione destro	Rim R.H.	Jante droit	Felge rechts	1						0	0
45	15044100	Dado	Nut	Ecrou	Mutter	4						0	0
46	83100008	Rondella elastica	Spring washer	Rondelle élastique	Federscheibe	4						0	0
47	15044110	Dado	Nut	Ecrou	Mutter	4						0	0
48	83100008	Rondella elastica	Spring washer	Rondelle élastique	Federscheibe	4						0	0
49	19744074	Piastrina di sicurezza	Locking plate	Plaquette de blocage	Sicherungsblech	1						0	0
50	19744067	Anello elastico	Circlip	Circlip	Seegerring	1						0	0
51	19744068	Griglia	Grille	Grille	Gitter	4						0	0

* { con fig. with Fig. avec fig. mit Abb. } 30 - 31 - 32 - 37.

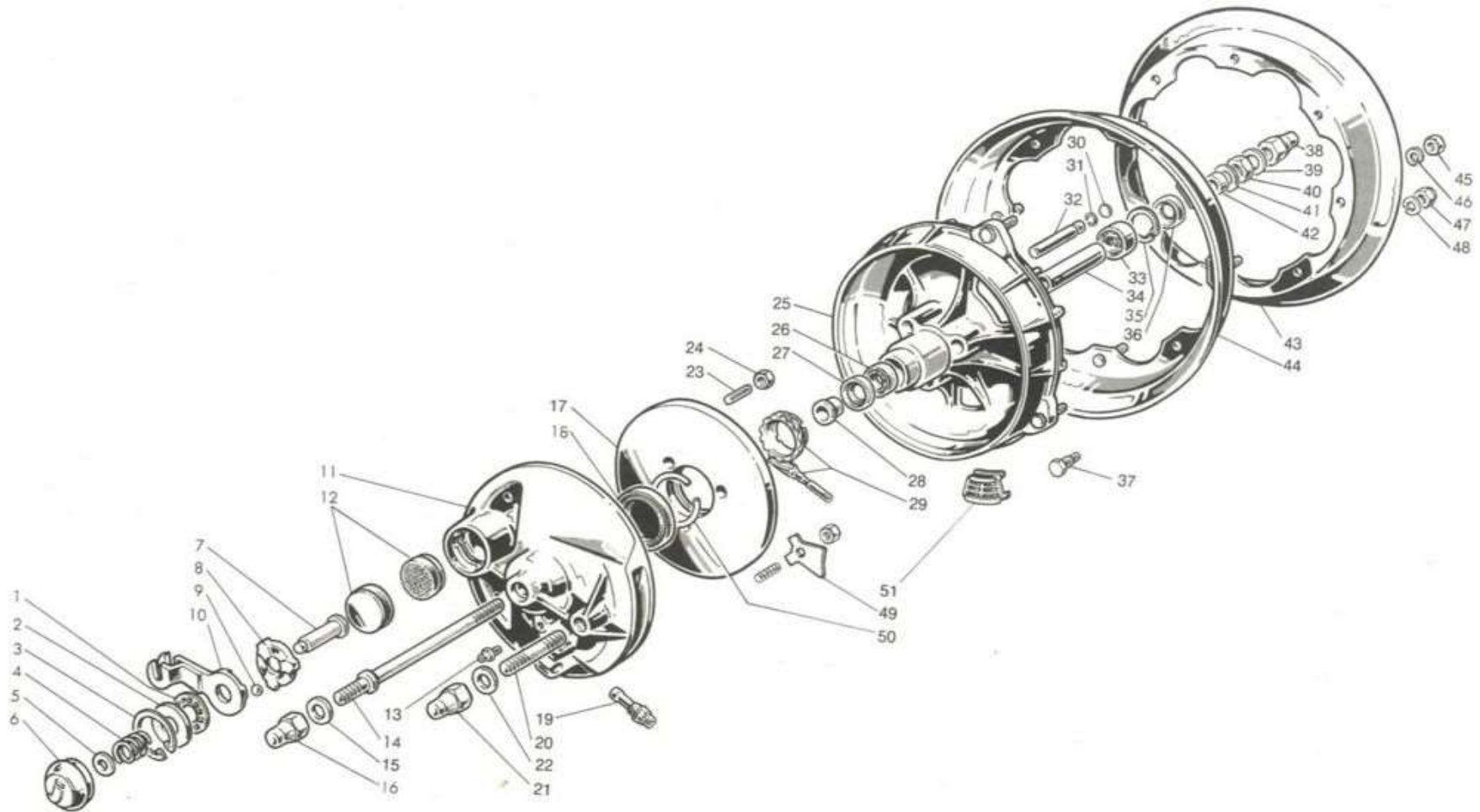

19-069



www.rpvi.it

XI
XII
XIII
XIV
XV
XVI
XVII

Fig. Abb.	Ord. No. Bestell N.	Denominazione	Description	Désignation	Benennung	Qt. Anzahl	125 LI	125 S	150 LI	150 S	150 SX	175 TV	200 SX
—	19983010	Fanalino	Tail light	Feu arrière	Schlussleuchte	1	o	o	o	o	o	o	o
1	19983002 †	Vite CARELLO	Screw	Vis	Schraube	2	o		o	o		o	
	19983022 †	Vite CEV - APRILIA	Screw	Vis	Schraube	2	o	o	o	o	o	o	o
	71270340 †	Vite	Screw	Vis	Schraube	2	o		o	o		o	
	19983003	Rondella CARELLO	Washer	Rondelle	Scheibe	2	o		o	o		o	
3	19083180	Catadiottro CEV	Red gem	Catadioptré	Rückstrahler	1	o	o	o	o	o	o	o
	19983001	Catadiottro CARELLO	Red gem	Catadioptré	Rückstrahler	1	o		o	o		o	
	19983100	Catadiottro APRILIA	Red gem	Catadioptré	Rückstrahler	1	o	o	o	o	o	o	o
4	19983004	Guarnizione CARELLO	Gasket	Joint	Dichtung	1	o		o	o		o	
	19983009	Guarnizione CEV	Gasket	Joint	Dichtung	1	o	o	o	o	o	o	o
	19983016	Guarnizione APRILIA	Gasket	Joint	Dichtung	1	o	o	o	o	o	o	o
5	19983060	Parabola CEV	Reflector	Réflecteur	Reflektor	1	o	o	o	o	o	o	o
	19983090	Parabola APRILIA	Reflector	Réflecteur	Reflektor	1	o	o	o	o	o	o	o
6	19983018	Vite	Screw	Vis	Schraube	2	o	o	o	o	o	o	o
7	—	(Non si fornisce)	(Is not supplied.)	(N'est pas fourni.)	(Nicht lieferbar.)	—							
8	19983021	Guarnizione	Gasket	Joint	Dichtung	1	o	o	o	o	o	o	o
9	83100006	Rondella	Washer	Rondelle	Scheibe	2	o	o	o	o	o	o	o
10	82058010	Dado	Nut	Ecrou	Mutter	4	o	o	o	o	o	o	o
11	83100006	Rondella	Washer	Rondelle	Scheibe	2	o	o	o	o	o	o	o
12	87570315	Lampadina 6 V. 3/15 W.	Bulb 6 V. 3/15 W.	Ampoule 6 V. 3/15 W.	Lampe 6 V. 3/15 W.	1	o	o	o	o	o	o	o
13	19082050	Cavetto di massa	Earth wire	Câble de masse	Massekabel	1	o	o	o	o	o	o	o
14	19082130	Cavetto di massa	Earth wire	Câble de masse	Massekabel	1	o	o	o	o	o	o	o
15	15017006	Passacavo per cavo A.T.	Grommet for H.T. Cable	Passe câble H.T.	Hsp. Kabelführung	1	o	o	o	o	o	o	o
—	19780010	Fanale	Headlamp	Phare	Scheinwerfer	1		o		o	o	o	o
16	19780050	Riflettore/vetro CEV	Reflector/glass	Réflecteur/verre	Reflektor/Glas	1		o		o	o	o	o
	19780070	Riflettore/vetro CARELLO	Reflector/glass	Réflecteur/verre	Reflektor/Glas	1		o		o	o	o	o
17	19980030	Portalampada CARELLO	Lampholder	Douille d'ampoule	Lampenfassung	1		o		o	o	o	o
	19980070	Portalampada CEV	Lampholder	Douille d'ampoule	Lampenfassung	1		o		o	o	o	o
18	19980003	Molla CARELLO	Spring	Ressort	Feder	1		o		o	o	o	o
	19980080	Molla CEV	Spring	Ressort	Feder	1		o		o	o	o	o

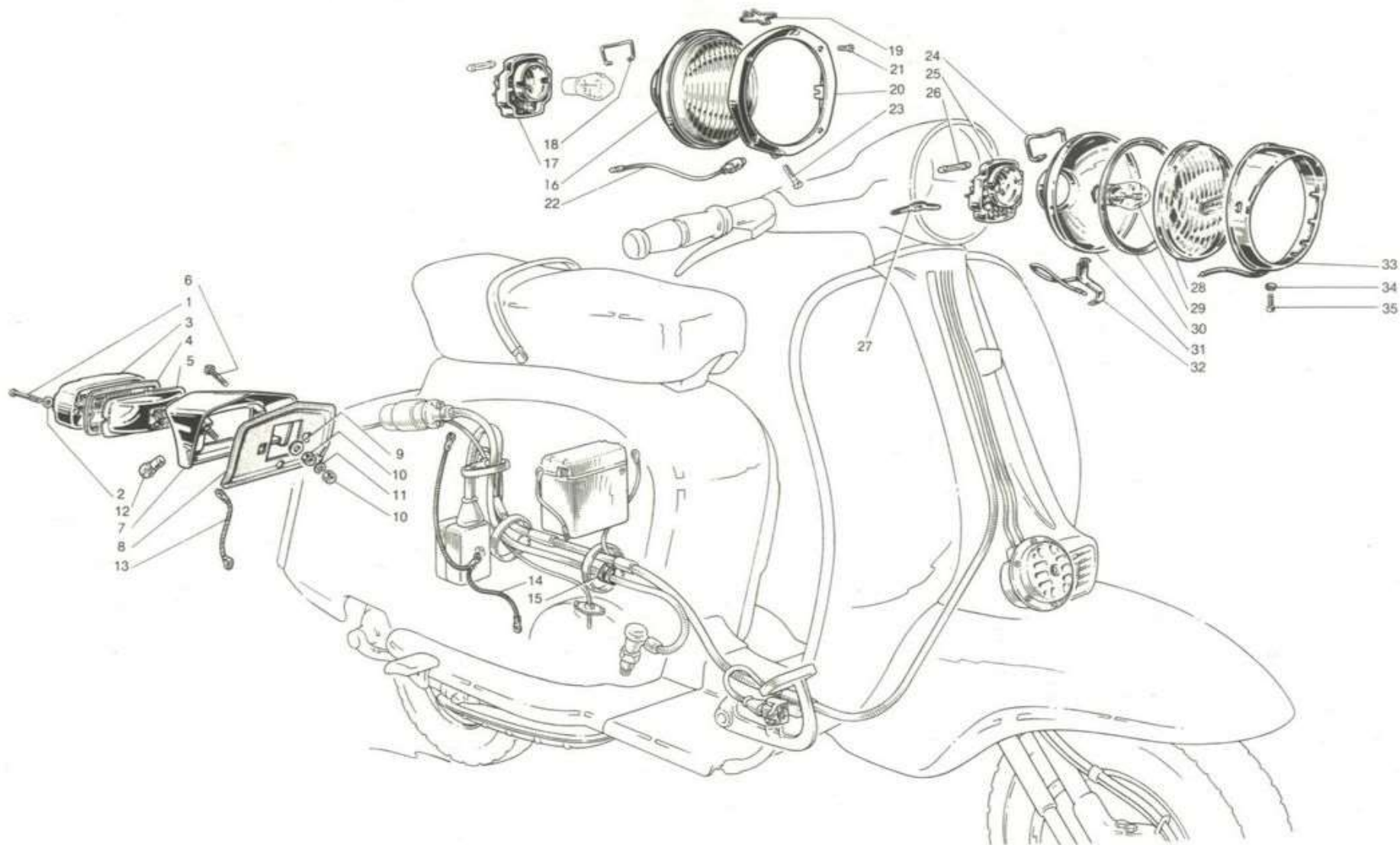

19-070

INNOCENTI

www.rpww.it

XI
XII
XIII
XIV
XV
XVI
XVII

Fig. Abb.	Ord. No. Bestell N.	Denominazione	Description	Désignation	Benennung	Qt. Anzahl	125 LI	125 S	150 LI	150 S	150 SX	175 TV	200 SX
19	19780007	Molla CARELLO	Spring	Ressort	Feder	1		0	0	0	0	0	0
	19780012	Molla CEV	Spring	Ressort	Feder	1		0	0	0	0	0	0
20	19780001	Cornice CEV - CARELLO	Headlamp rim	Porte chromée	Deckelring	1		0	0	0	0	0	0
21	19780011	Vite	Screw	Vis	Schraube	4		0	0	0	0	0	0
22	19780009	Barilotto CEV - CARELLO	Trunnion	Barillet	Spannbolzen	1		0	0	0	0	0	0
23	19780008	Vite CEV - CARELLO	Screw	Vis	Schraube	1		0	0	0	0	0	0
—	19980010	Fanale	Headlamp	Phare	Scheinwerfer	1	0		0				
24	19980003	Molla CARELLO	Spring	Ressort	Feder	1	0		0				
	19980016	Molla APRILIA	Spring	Ressort	Feder	2	0		0				
	19980080	Molla CEV	Spring	Ressort	Feder	1	0		0				
25	19980030	Portalampada CARELLO	Lampholder	Douille d'ampoule	Lampenfassung	1	0		0				
	19980070	Portalampada CEV	Lampholder	Douille d'ampoule	Lampenfassung	1	0		0				
	19980140	Portalampada APRILIA	Lampholder	Douille d'ampoule	Lampenfassung	1	0		0				
26	87550500	Lampadina 6 V. 5 W.	Bulb 6 V. 5 W.	Ampoule 6 V. 5 W.	Lampe 6 V. 5 W.	1	0	0	0	0	0	0	0
27	19982005	Fascetta	Clip	Collier	Klemmschelle	1	0	0	0	0	0	0	0
28	19980005	Vetro CARELLO	Glass	Verre	Glas	1	0		0				
	19980009	Vetro CEV	Glass	Verre	Glas	1	0		0				
	19980014	Vetro APRILIA	Glass	Verre	Glas	1	0		0				
29	87652525	Lampadina 6 V. 25/25 W.	Bulb 6 V. 25/25 W.	Ampoule 6 V. 25/25 W.	Lampe 6 V. 25/25 W.	1	0	0	0	0	0	0	0
30	19980006	Guarnizione CARELLO	Gasket	Joint	Dichtung	1	0		0				
	19980008	Guarnizione CEV	Gasket	Joint	Dichtung	1	0		0				
	19980015	Guarnizione APRILIA	Gasket	Joint	Dichtung	1	0		0				
31	19980100	Parabola CEV	Reflector	Réflecteur	Reflektor	1	0		0				
	19980110	Parabola CARELLO	Reflector	Réflecteur	Reflektor	1	0		0				
	19980130	Parabola APRILIA	Reflector	Réflecteur	Reflektor	1	0		0				
32	19980040	Molla CARELLO	Spring	Ressort	Feder	1	0		0				
33	19980004	Cornice CARELLO	Headlamp rim	Porte chromée	Deckelring	1	0		0				
	19980013	Cornice APRILIA	Headlamp rim	Porte chromée	Deckelring	1	0		0				
	19980090	Cornice CEV	Headlamp rim	Porte chromée	Deckelring	1	0		0				

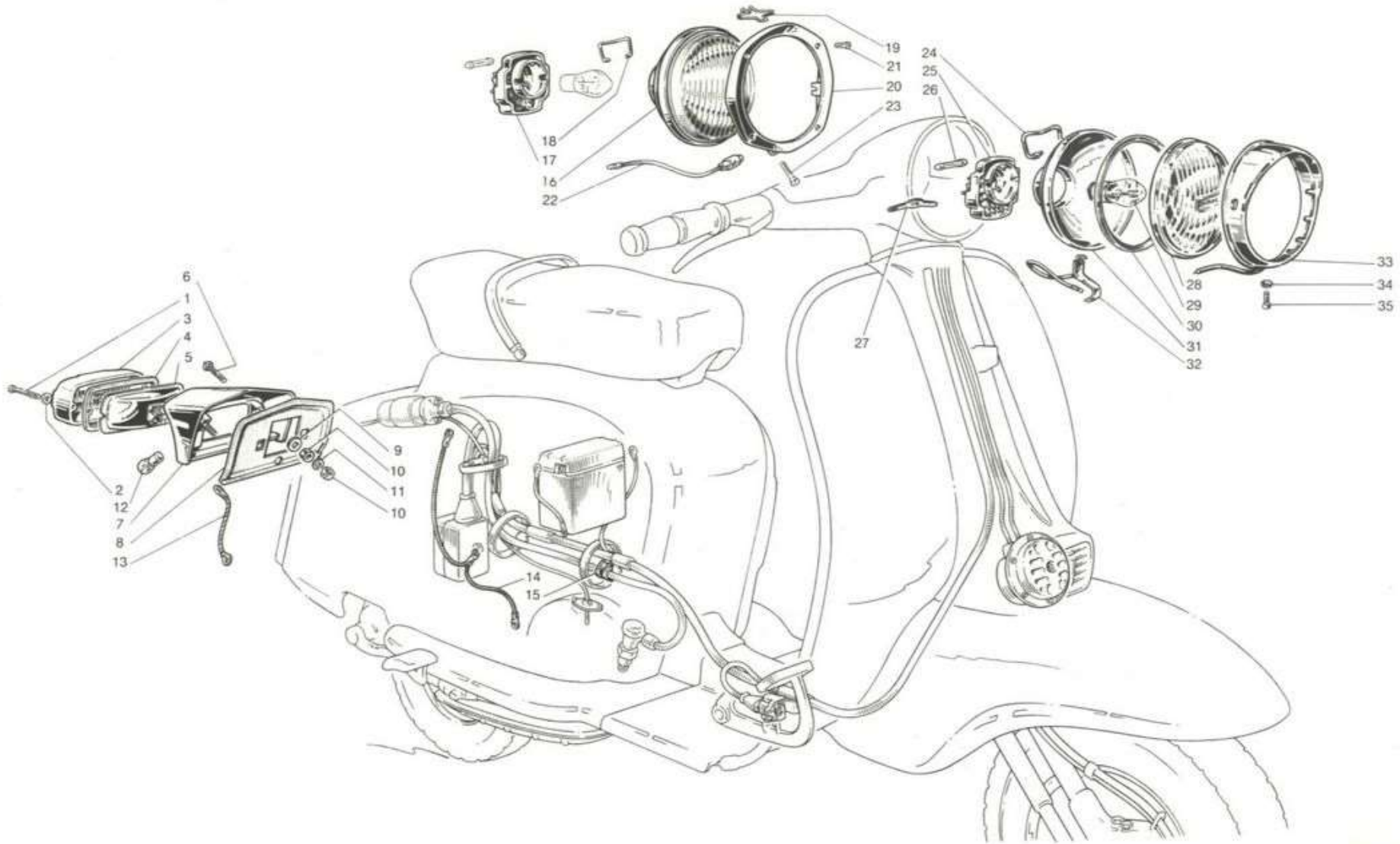

19-070



XII
XIII
XIV
XV
XVI
XVII
www.tpw.it

Fig. Abb.	Ord. No. Bestell N.	Denominazione	Description	Désignation	Benennung	Qt. Anzahl	125 LI	125 S	150 LI	150 S	150 SX	175 TV	200 SX
34	19980002	Borchia	Cone washer	Rosette	Abstandring	3	0		0				
35	71480412	Vite	Screw	Vis	Schraube	3	0		0				

† Pre-modifica. Pre-modification. Pré-modification. Vor-Aenderung.
 ‡ Post-modifica. Post-modification. Post-modification Nach-Aenderung.

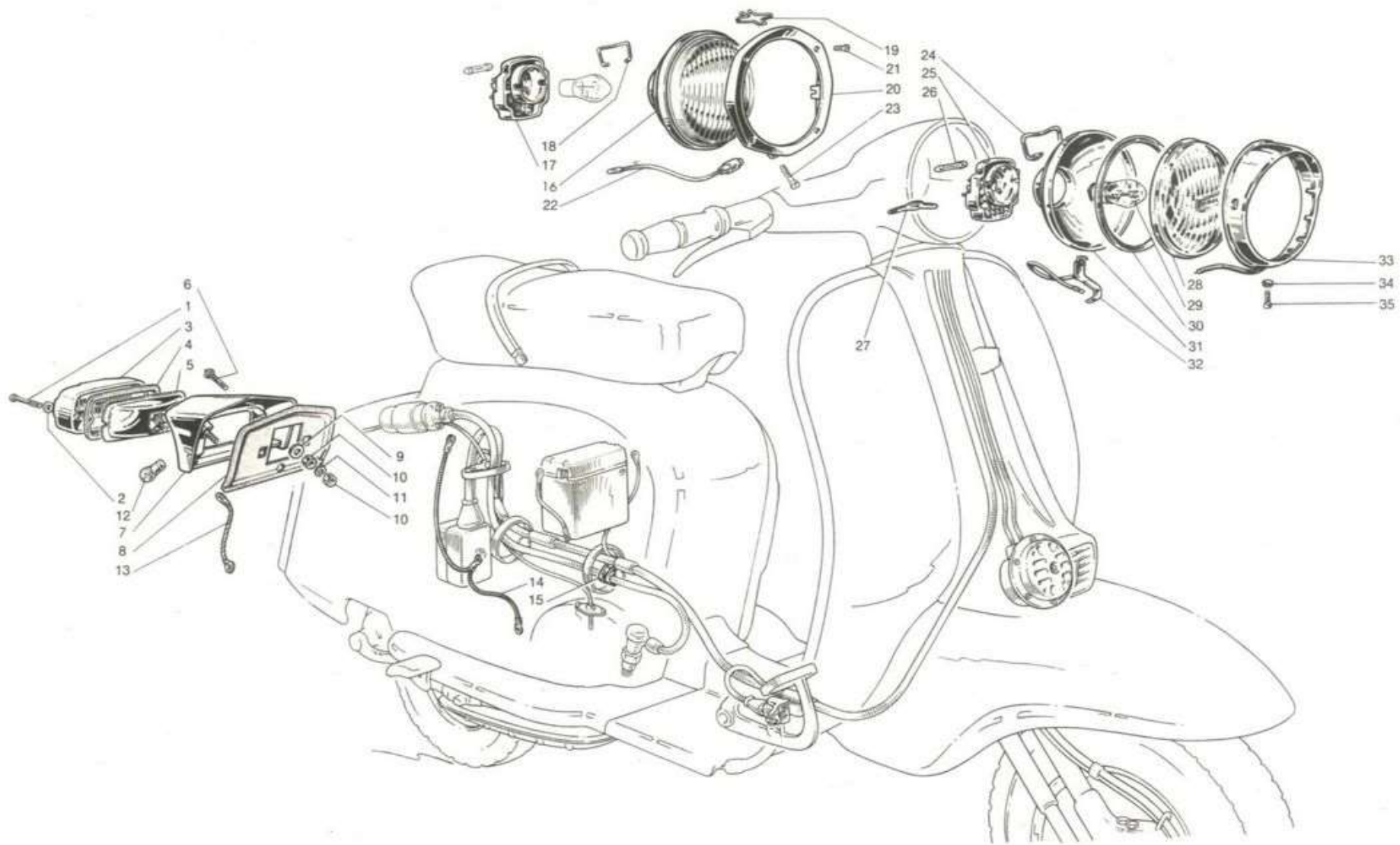

19-070



www.rpwin.it

XII
XIII
XIV
XV
XVI
XVI

Fig. Abb.	Ord. No. Bestell N.	Denominazione	Description	Désignation	Benennung	Qt. Anzahl	125 LI	125 S	150 LI	150 S	150 SX	175 TV	200 SX
1	19981010	Cintura	Strap	Collier	Spannband	1			o			o	o
2	19981005	Tappeto	Mat	Tapis	Teppich	1			o			o	o
3	70330530	Vite	Screw	Vis	Schraube	1			o			o	o
4	19981031	Cilindretto	Trunnion	Barillet	Spannbolzen	1			o			o	o
5	19981029	Dado ad alette	Wing nut	Ecrou à chapeau	Flügelmutter	1			o			o	o
6	15082020	Trecciola	Earth wire	Câble de masse	Massekabel	1			o			o	o
7	82058009	Dado	Nut	Ecrou	Mutter	1			o			o	o
8	83110005	Rondella	Washer	Rondelle	Scheibe	2			o			o	o
9	81008127	Vite	Screw	Vis	Schraube	1			o			o	o
10	15017070	Attacco rapido	Cap	Capuchon	Stecker	1	o	o	o	o	o	o	o
11	19017016	Gommino	Grommet	Passe-câble	Gummitülle	1	o	o	o	o	o	o	o
12	15017013	Cavo A.T.	H.T. Lead	Cable H.T.	Hsp. Kabel	1	o	o	o	o	o	o	o
13	19917023	Passacavo	Fairlead	Passe-câble	Kabelführung	1	o	o	o	o	o	o	o
14	87310001	Bussola (4 MA)	Bush	Bague	Büchse	1	o	o	o	o	o	o	o
	87310005	Bussola (5/32")	Bush	Bague	Büchse	1	o	o	o	o	o	o	o
15	15017040	Candela	Spark plug	Bougie	Zündkerze	1	o	o	o	o	o	o	o
16	19081410	Coperchio	Cover	Couvercle	Deckel	1			o			o	o
17	82058007	Dado	Nut	Ecrou	Mutter	2			o			o	o
18	73170043	Rondella elastica	Spring washer	Rondelle élastique	Federscheibe	2			o			o	o
19	73020043	Rondella	Washer	Rondelle	Scheibe	2			o			o	o
20	70360410	Vite	Screw	Vis	Schraube	2			o			o	o
21	19981030	Batteria con fig. 16	Battery with fig. 16	Batterie avec fig. 16	Batterie mit Abb. 16	1			o			o	o
22	82058010	Dado	Nut	Ecrou	Mutter	1	o	o	o	o	o	o	o
23	83100006	Rondella	Washer	Rondelle	Scheibe	1	o	o	o	o	o	o	o
24	20062030 *	Morsettiera 6-poli	Junction box	Plaquette de dérivation	Anschlussplatte	1	o	o	o	o	o		
25	20062002	Cappuccio	Cap	Capuchon	Haube	1	o	o	o	o	o		
26	87200008	Fusibile 8 A	Fuse 8 A	Fusible 8 A	Sicherung 8 A	1			o				
27	19981050	Pulsante di massa	Engine cut out button	Bouton de masse	Massedruckknopf	1	o		o			o	o
28	71490322	Vite	Screw	Vis	Schraube	2			o			o	o
29	19281230	Devioluci	Headlamp switch	Commutateur	Lichtschalter	1			o			o	o

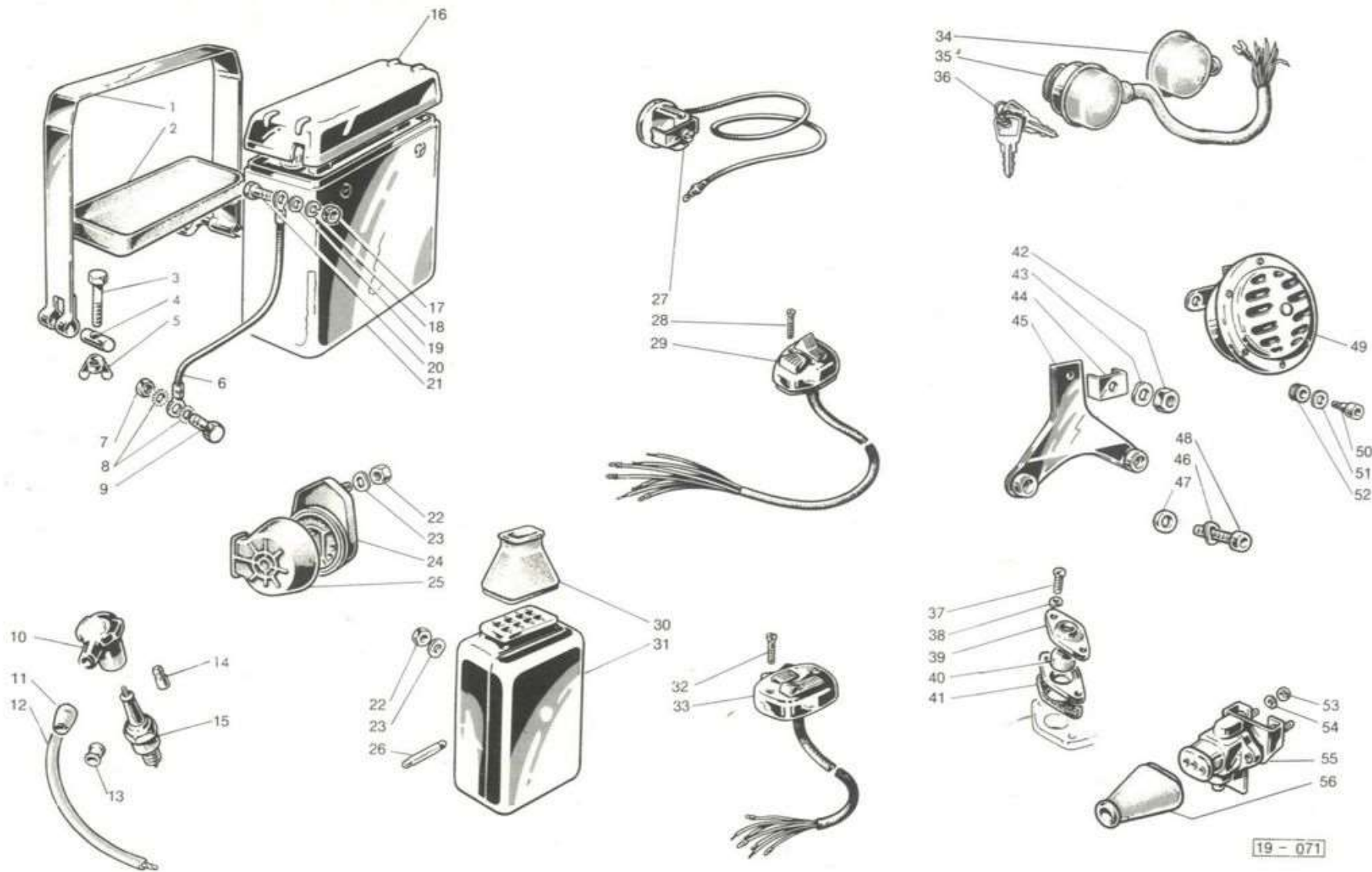

19 - 071



www.rpw.it

XII
XIII
XIV
XV
XVI
XVII

Fig. Abb.	Ord. No. Bestell N.	Denominazione	Description	Désignation	Benennung	Qt. Anzahl	125 LI	125 S	150 LI	150 S	150 SX	175 TV	200 SX
30	19081033	Cappuccio	Cap	Capuchon	Haube	1	o	o	o	o	o	o	o
31	19081380	■ Regolatore 4 poli	Regulator	Régulateur	Regler	1			o			o	
	19181380	* Impedenza 4 poli	Impedance	Impédance	Impedanz	1	o		o				
	19981420	■ Regolatore 6 poli	Regulator	Régulateur	Regler	1			o			o	o
32	71490322	Vite	Screw	Vis	Schraube	2	o		o				
33	19881040	* Quadretto 4-6 poli	Switch	Commutateur	Zündschalter	1	o	o	o	o	o		
	19981040	■ Quadretto 4 poli	Switch	Commutateur	Zündschalter	1			o			o	
	19981070	■ Quadretto 6 poli	Switch	Commutateur	Zündschalter	1			o			o	o
34	19781001	Protezione	Protection cap	Capuchon	Schutzhaube	1		o		o	o	o	o
35	19781040	■ Quadretto 4 poli	Switch	Commutateur	Zündschalter	1						o	
	19781050	* Quadretto 6 poli	Switch	Commutateur	Zündschalter	1		o		o	o		
	19781070	■ Quadretto 6 poli	Switch	Commutateur	Zündschalter	1						o	o
36	00205501	Chiave	Key	Clé	Schlüssel	2		o	o	o	o	o	o
37	70850412	Vite	Screw	Vis	Schraube	2	o	o	o	o	o	o	o
38	83100004	Rondella	Washer	Rondelle	Scheibe	2	o	o	o	o	o	o	o
39	19017017	Piastrina	Plate	Plaque	Blech	2	o	o	o	o	o	o	o
40	19017018	Passacavo	Grommet	Passe-câble	Gummitülle	1	o	o	o	o	o	o	o
41	15017007	Guarnizione	Gasket	Joint	Dichtung	1	o	o	o	o	o	o	o
42	82058012	Dado	Nut	Ecrou	Mutter	1	o	o	o	o	o	o	o
43	83100008	Rondella elastica	Spring washer	Rondelle élastique	Federscheibe	1	o	o	o	o	o	o	o
44	19081048	Cavallotto	Stirrup	Étrier	Krampe	1	o	o	o	o	o	o	o
45	19981020	Balestra	Bracket	Support	Stütze	1	o	o	o	o	o	o	o
46	83110006	Rondella elastica	Spring washer	Rondelle élastique	Federscheibe	1	o	o	o	o	o	o	o
47	19981049	Rondella	Washer	Rondelle	Scheibe	2	o	o	o	o	o	o	o
48	19950114	Vite	Screw	Vis	Schraube	2	o	o	o	o	o	o	o
49	19581500	* Avvisatore	Horn	Avertisseur	Horn	1	o	o	o	o	o		
	19681500	■ Avvisatore	Horn	Avertisseur	Horn	1			o				
50	19581501	Vite	Screw	Vis	Schraube	2							o
51	73010084	Rondella piana	Plain washer	Rondelle plate	Unterlegscheibe	2							o
52	19581502	Gommino	Grommet	Anneau caoutchouc	Gummitülle	2							o

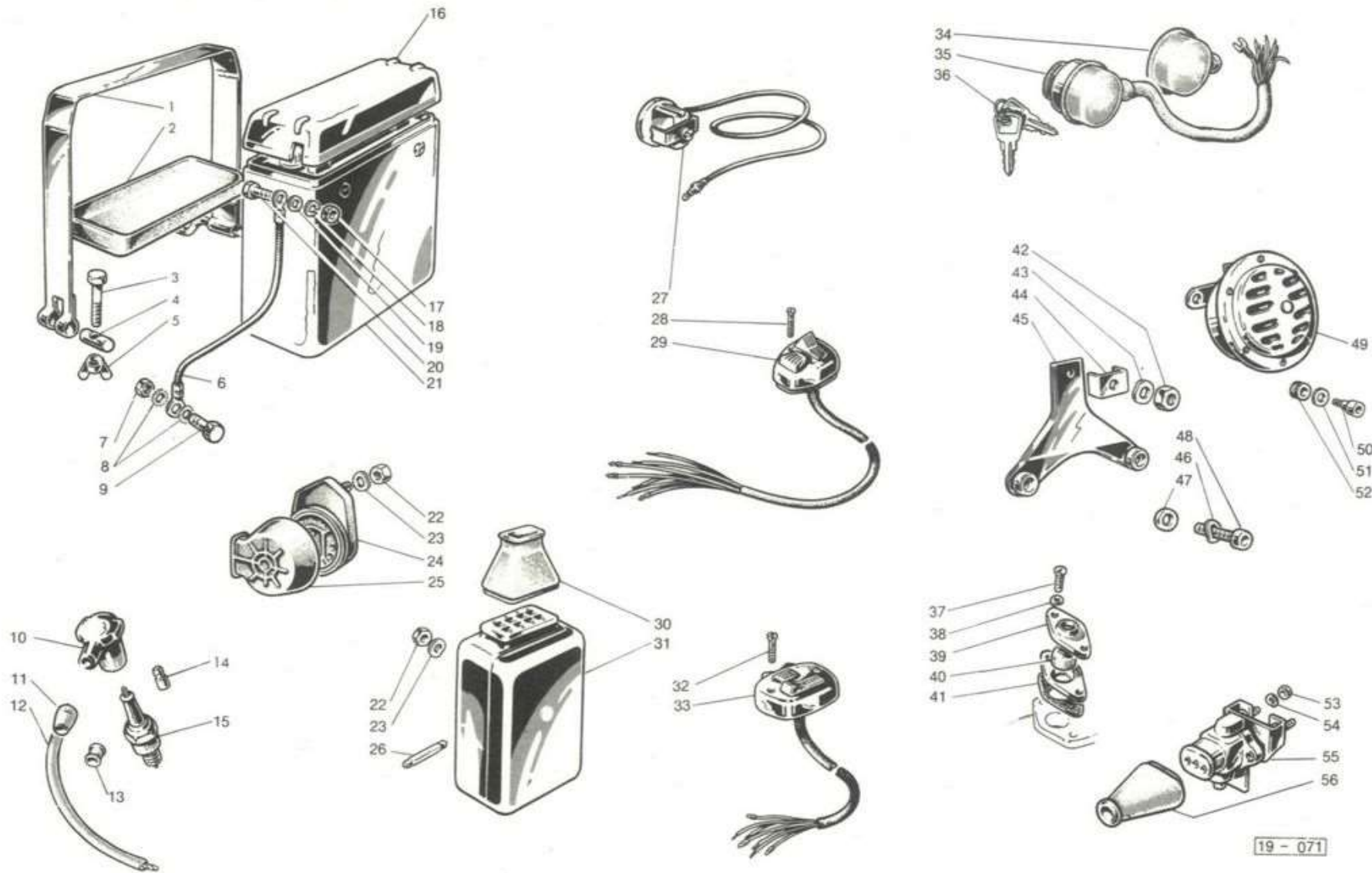

19 - 071

XIII
XIV
XV
XVI
XVII
www.rpw.it

Fig. Abb.	Ord. No. Bestell N.	Denominazione	Description	Désignation	Benennung	Qt. Anzahl	125 LI	125 S	150 LI	150 S	150 SX	175 TV	200 SX
53	82058007	Dado	Nut	Ecrou	Mutter	2	o	o	o	o	o	o	o
54	83100004	Rondella elastica	Spring washer	Rondelle élastique	Federscheibe	2	o	o	o	o	o	o	o
55	19081390 ■	Interruttore stop	Stop light switch	Interrupteur de stop	Bremslichtschalter	1			o			o	
	19181390 *	Interruttore stop	Stop light switch	Interrupteur de stop	Bremslichtschalter	1	o		o				
	19981400	Interruttore stop	Stop light switch	Interrupteur de stop	Bremslichtschalter	1	o	o	o	o	o	o	o
56	19081045	Protezione	Cap	Capuchon	Schutzhaube	1	o		o			o	
	19981046	Protezione	Cap	Capuchon	Schutzhaube	1	o	o	o	o	o	o	o

* { Per impianto elettrico senza batteria.
For electrical equipment without battery.
Pour appareillage électrique sans batterie.
Für elektrische Ausrüstung ohne Batterie.

■ { Per impianto elettrico con batteria.
For electrical equipment with battery.
Pour appareillage électrique avec batterie.
Für elektrische Ausrüstung mit Batterie.

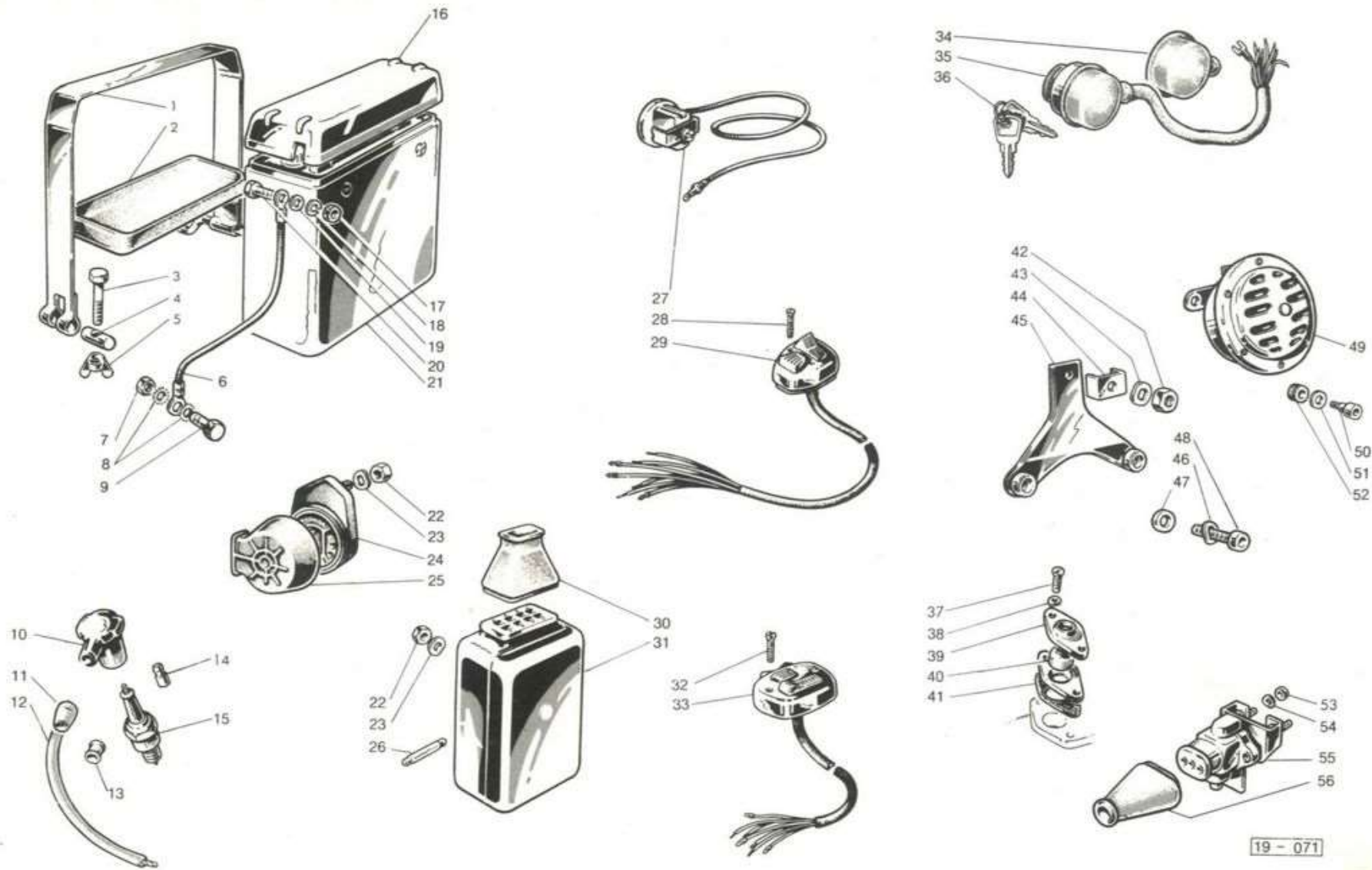

19 - 071



XIII
XIV
XV
XVI
XVII
www.rpw.it

Volano magnete « Ducati »
4 poli

« Ducati » 4-poles
flywheel magneto

Volant magnétique 4-pôles
« Ducati »

« Ducati » 4-poliger
Magnetzünder

Tav. XIII

Fig. Abb.	Ord. No. Bestell N.	Denominazione	Description	Désignation	Benennung	Qt. Anzahl	125 LI	125 S	150 LI	150 S	150 SX	175 TV	200 SX
-	00840013	Volano (con batteria)	Flywheel (with Battery)	Volant (avec Batterie)	Magnetzünder (mit Batterie)	1			o				
-	00840050	Volano (senza batteria)	Flywheel (without Battery)	Volant (sans Batterie)	Magnetzünder (ohne Batterie)	1	o		o				
-	00840042	Volano (con batteria)	Flywheel (with Battery)	Volant (avec Batterie)	Magnetzünder (mit Batterie)	1						o	
1	00840018	Bobina B.T. per 00840013	L.T. Coil	Bobine B.T.	Lichtanker	1			o				
	00840040	Bobina B.T. per 00840042	L.T. Coil	Bobine B.T.	Lichtanker	1						o	
	00840052	Bobina B.T. per 00840050	L.T. Coil	Bobine B.T.	Lichtanker	1	o		o				
2	19017014	Piastrina fissaggio cavi	Plate, wire fixing	Plaquette fixation câbles	Kabel-Befestigungsblech	1	o		o			o	
3	00840019	Feltro ingrassatore	Greaser felt	Feutre graisseur	Schmierfilz	1	o		o			o	
4	00840159 *	Statore comp. per 00840013	Stator assy	Ensemble stator	Statorgruppe	1			o				
	00840160 *	Statore comp. per 00840042	Stator assy	Ensemble stator	Statorgruppe	1						o	
	00840161 *	Statore comp. per 00840050	Stator assy	Ensemble stator	Statorgruppe	1	o		o				
5	00840015	Parte rotan. per 00840013/50	Flywheel	Rotor	Schwungrad	1	o		o				
	00840041	Parte rotante per 00840042	Flywheel	Rotor	Schwungrad	1						o	
6	00840058	Vite	Screw	Vis	Schraube	2	o		o			o	
7	83110004	Rondella elastica	Spring washer	Rondelle élastique	Federscheibe	2	o		o			o	
8	00840049	Condensatore	Condenser	Condensateur	Kondensator	1	o		o			o	
9	00840072	Gruppo contatti	Contact points	Rupteur	Unterbrecher	1	o		o			o	
10	00840017	Bobina B.T. per 00840013/42	L.T. Coil	Bobine B.T.	Nsp. Anker	1			o			o	
	00840051	Bobina B.T. per 00840050	L.T. Coil	Bobine B.T.	Nsp. Anker	1	o		o				
11	73170043	Rondella elastica	Spring washer	Rondelle élastique	Federscheibe	4	o		o			o	
12	71180425	Vite	Screw	Vis	Schraube	4	o		o			o	
13	70300625	Vite	Screw	Vis	Schraube	3	o		o			o	
14	83100006	Rondella elastica	Spring washer	Rondelle élastique	Federscheibe	3	o		o			o	
15	00840070	Molla	Spring	Ressort	Feder	1	o		o			o	
16	00840069	Coperchietto	Cover	Couvercle	Deckel	1	o		o			o	
17	19917024	Dado	Nut	Ecrou	Mutter	1	o		o			o	
18	19917025	Rondella elastica	Spring washer	Rondelle élastique	Federscheibe	1	o		o			o	
19	19917092	Vite	Screw	Vis	Schraube	2	o		o			o	
20	83100004	Rondella elastica	Spring washer	Rondelle élastique	Federscheibe	2	o		o			o	
21	00840082	Bobina A.T.	H.T. Coil	Bobine H.T.	Zündspule	1	o		o			o	

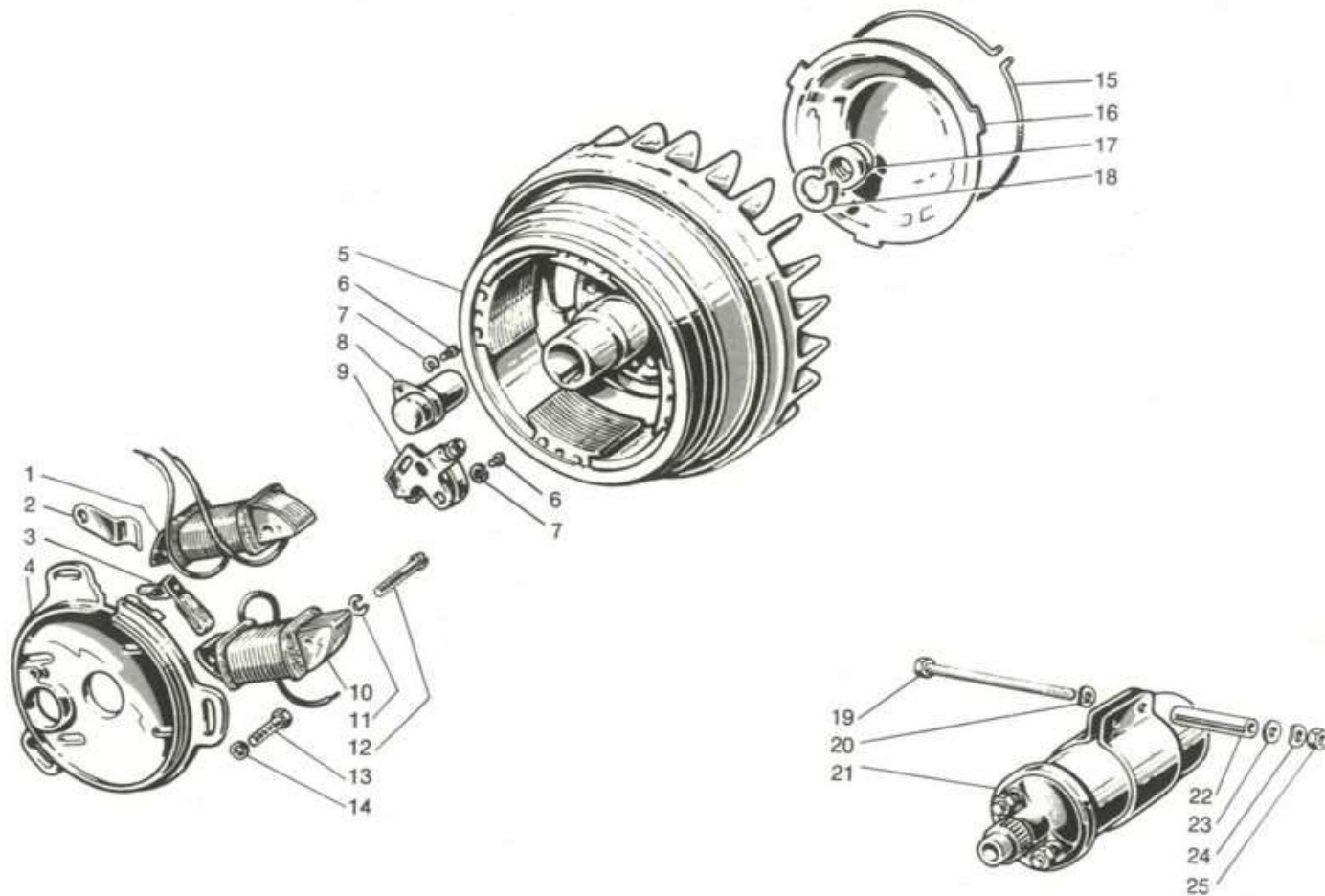

19 - 072



XIII
XIV
XV
XVI
XVII
www.rpw.it

Volano magnete « Ducati »
4 poli

« Ducati » 4-poles
flywheel magneto

Volant magnétique 4-pôles
« Ducati »

« Ducati » 4-poliger
Magnetzûnder

Tav. XIII

Fig. Abb.	Ord. No. Bestell N.	Denominazione	Description	Désignation	Benennung	Qt. Anzahl	125 LI	125 S	150 LI	150 S	150 SX	175 TV	200 SX
22	19917093	Distanziale	Distance piece	Entretoise	Abstandstück	2	○		○			○	
23	73060043	Rondella	Washer	Rondelle	Scheibe	2	○		○			○	
24	83100004	Rondella elastica	Spring washer	Rondelle élastique	Federscheibe	2	○		○			○	
25	82058007	Dado	Nut	Ecrou	Mutter	2	○		○			○	

* { Statore completo con figg.
Stator assy with fig.
Ensemble stator avec fig.
Statorgruppe mit Abb. } 1 - 2 - 3 - 6 - 7 - 8 - 9 - 10 - 11 - 12.

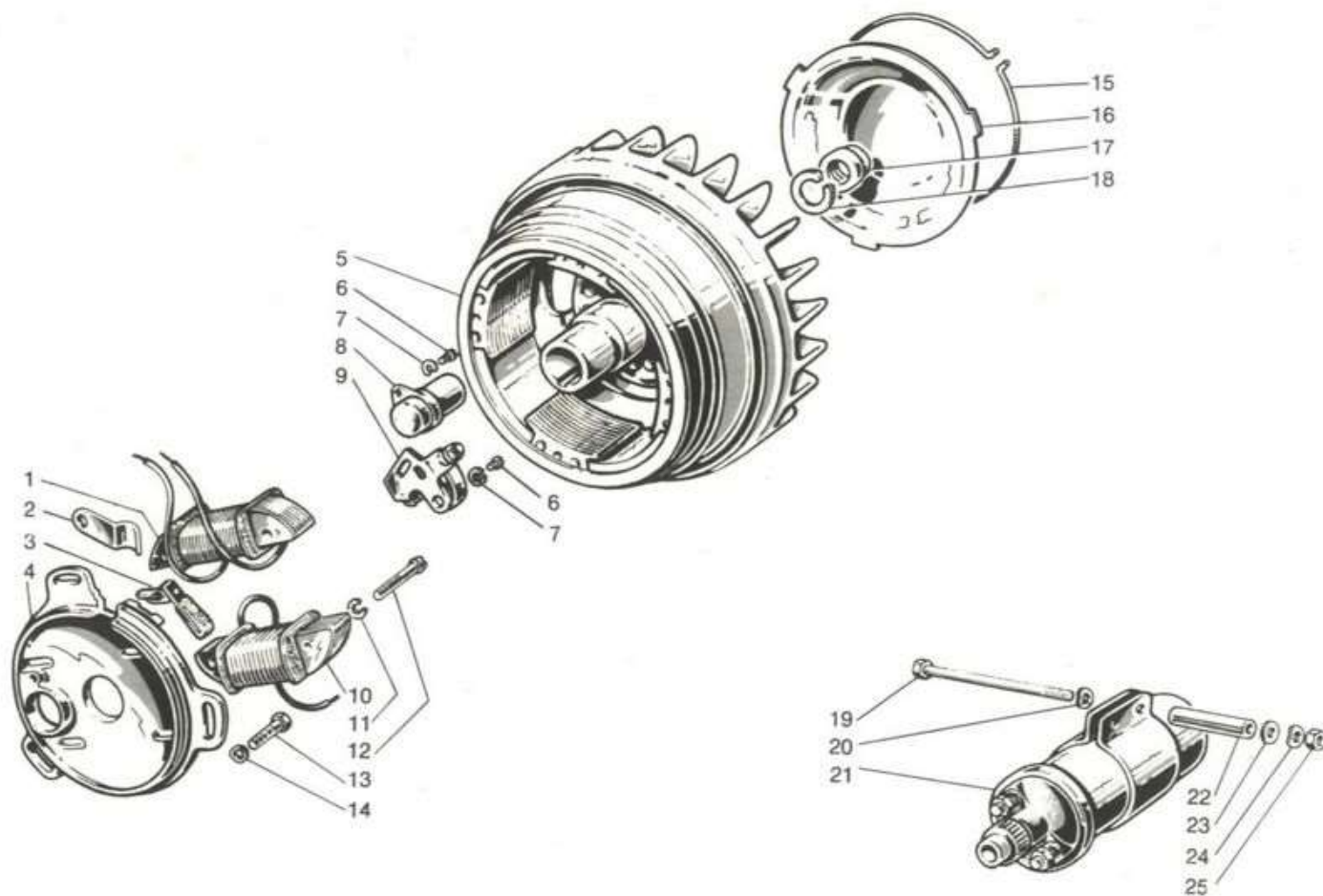

19 - 072

www.rpw.it

XIV
XV
XVI
XVII

Volano magnete «Ducati»
6 poli

«Ducati» 6-poles
flywheel magneto

Volant magnétique 6-pôles
«Ducati»

«Ducati» 6-poliger
Magnetzündler

Tav. XIV

Fig. Abb.	Ord. No. Bestell N.	Denominazione	Description	Désignation	Benennung	Qt. Anzahl	125 LI	125 S	150 LI	150 S	150 SX	175 TV	200 SX
-	00840083	Volano (senza batteria)	Flywheel (without Battery)	Volant (sans Batterie)	Magnetzündler (ohne Batterie)	1	o	o	o	o	o		
-	00840088	Volano (con batteria)	Flywheel (with Battery)	Volant (avec Batterie)	Magnetzündler (mit Batterie)	1						o	o
1	{ 00840102 *	Statore comp. per 00840083	Stator assy	Ensemble stator	Statorgruppe	1	o	o	o	o	o		
	{ 00840103 *	Statore comp. per 00840088	Stator assy	Ensemble stator	Statorgruppe	1						o	o
2	00840058	Vite	Screw	Vis	Schraube	1	o	o	o	o	o	o	o
3	83110004	Rondella elastica	Spring washer	Rondelle élastique	Federscheibe	1	o	o	o	o	o	o	o
4	00840060	Condensatore	Condenser	Condensateur	Kondensator	1	o	o	o	o	o	o	o
5	83100006	Rondella	Washer	Rondelle	Scheibe	3	o	o	o	o	o	o	o
6	70300625	Vite	Screw	Vis	Schraube	3	o	o	o	o	o	o	o
7	00840085	Bobina II	Coil II	Bobine II	Spule II	1	o	o	o	o	o	o	o
8	{ 00840163	Bobina V per 00840088	Coil V	Bobine V	Spule V	1						o	o
	{ 00840081	Bobina V per 00840083	Coil V	Bobine V	Spule V	1	o	o	o	o	o		
9	{ 00840074	Bobina I per 00840083	Coil I	Bobine I	Spule I	1	o	o	o	o	o		
	{ 00840084	Bobina I per 00840088	Coil I	Bobine I	Spule I	1						o	o
10	00840058	Vite	Screw	Vis	Schraube	1	o	o	o	o	o	o	o
11	83110004	Rondella elastica	Spring washer	Rondelle élastique	Federscheibe	1	o	o	o	o	o	o	o
12	00840059	Gruppo contatti	Contact points	Rupteur	Unterbrecher	1	o	o	o	o	o	o	o
13	83110004	Rondella elastica	Spring washer	Rondelle élastique	Federscheibe	1	o	o	o	o	o	o	o
14	00840058	Vite	Screw	Vis	Schraube	1	o	o	o	o	o	o	o
15	00840079	Parte rotante	Flywheel	Rotor	Schwungrad	1	o	o	o	o	o	o	o
16	00840077	Bobina III	Coil III	Bobine III	Spule III	1	o	o	o	o	o	o	o
17	{ 00840078	Bobina IV per 00840083	Coil IV	Bobine IV	Spule IV	1	o	o	o	o	o		
	{ 00840087	Bobina IV per 00840088	Coil IV	Bobine IV	Spule IV	1						o	o
18	00840057	Feltro ingrassatore	Greaser felt	Feutre graisseur	Schmierfilz	1	o	o	o	o	o	o	o
19	19917025	Rondella	Washer	Rondelle	Scheibe	1	o	o	o	o	o	o	o
20	19917024	Dado	Nut	Ecrou	Mutter	1	o	o	o	o	o	o	o
21	00840069	Coperchietto	Cover	Couvercle	Deckel	1	o	o	o	o	o	o	o
22	00840070	Molla	Spring	Ressort	Feder	1	o	o	o	o	o	o	o
23	19917092	Vite	Screw	Vis	Schraube	2	o	o	o	o	o	o	o
24	83100004	Rondella elastica	Spring washer	Rondelle élastique	Federscheibe	2	o	o	o	o	o	o	o

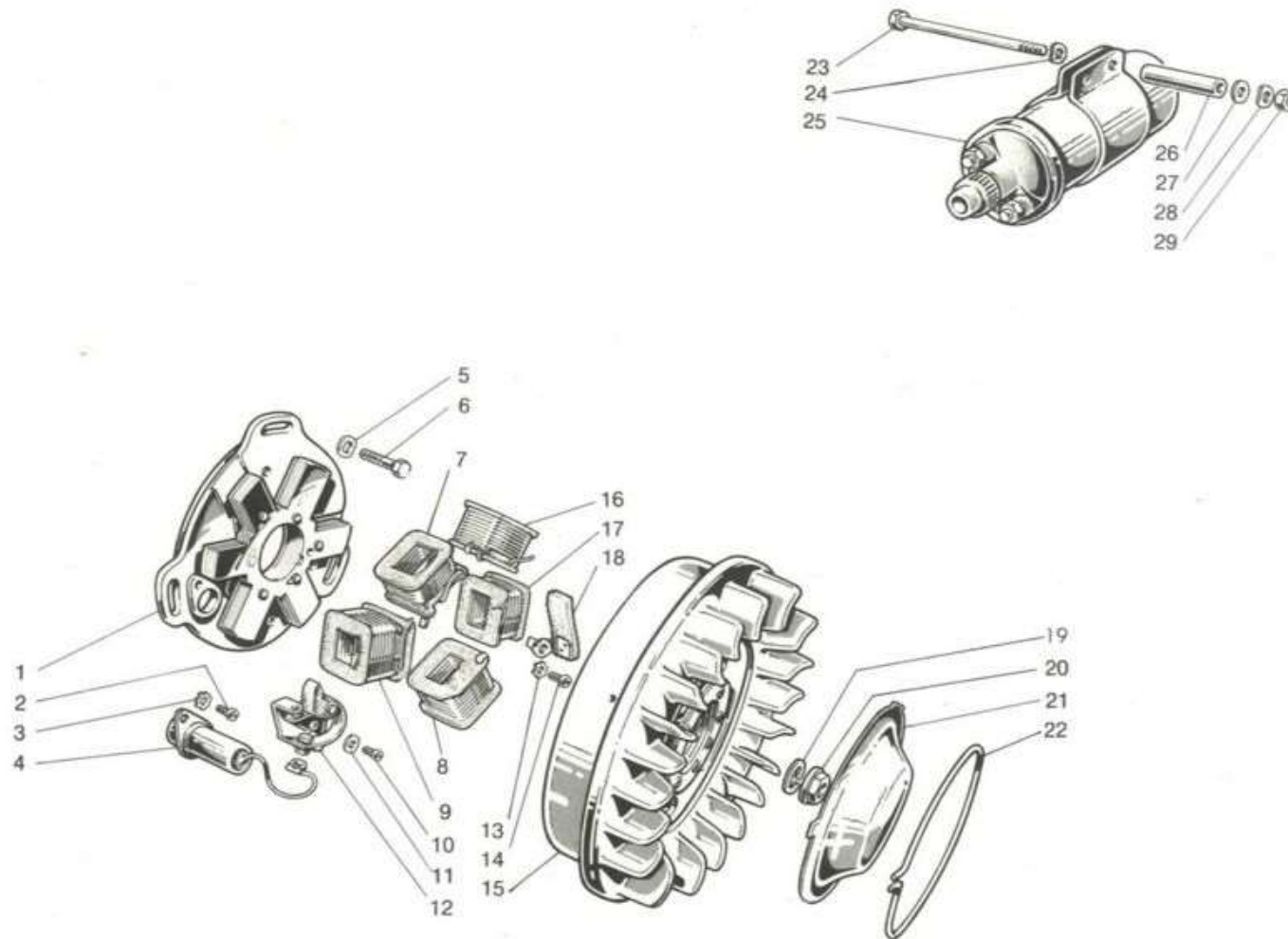

19 - 073

XIV
XV
XVI
XVII
www.rpwa.it

Volano magnete «Ducati »
6 poli

« Ducati » 6-poles
flywheel magneto

Volant magnétique 6-pôles
« Ducati »

« Ducati » 6-poliger
Magnetzündler

Tav. XIV

Fig. Abb.	Ord. No. Bestell N.	Denominazione	Description	Désignation	Benennung	Qr. Anzahl	125 LI	125 S	150 LI	150 S	150 SX	175 TV	200 SX
25	00840082	Bobina A.T.	H.T. Coil	Bobine H.T.	Zündspule	1	○	○	○	○	○	○	○
26	19917093	Distanziale	Distance piece	Entretoise	Abstandstück	2	○	○	○	○	○	○	○
27	73060043	Rondella	Washer	Rondelle	Scheibe	2	○	○	○	○	○	○	○
28	83100004	Rondella elastica	Spring washer	Rondelle élastique	Federscheibe	2	○	○	○	○	○	○	○
29	82058007	Dado	Nut	Ecrou	Mutter	2	○	○	○	○	○	○	○

* { Statore completo con figg.
Stator assy with fig.
Ensemble stator avec fig.
Statorgruppe mit Abb. } 2 - 3 - 4 - 7 - 8 - 9 - 10 - 11 - 12 - 13 - 14 - 16 - 17 - 18.

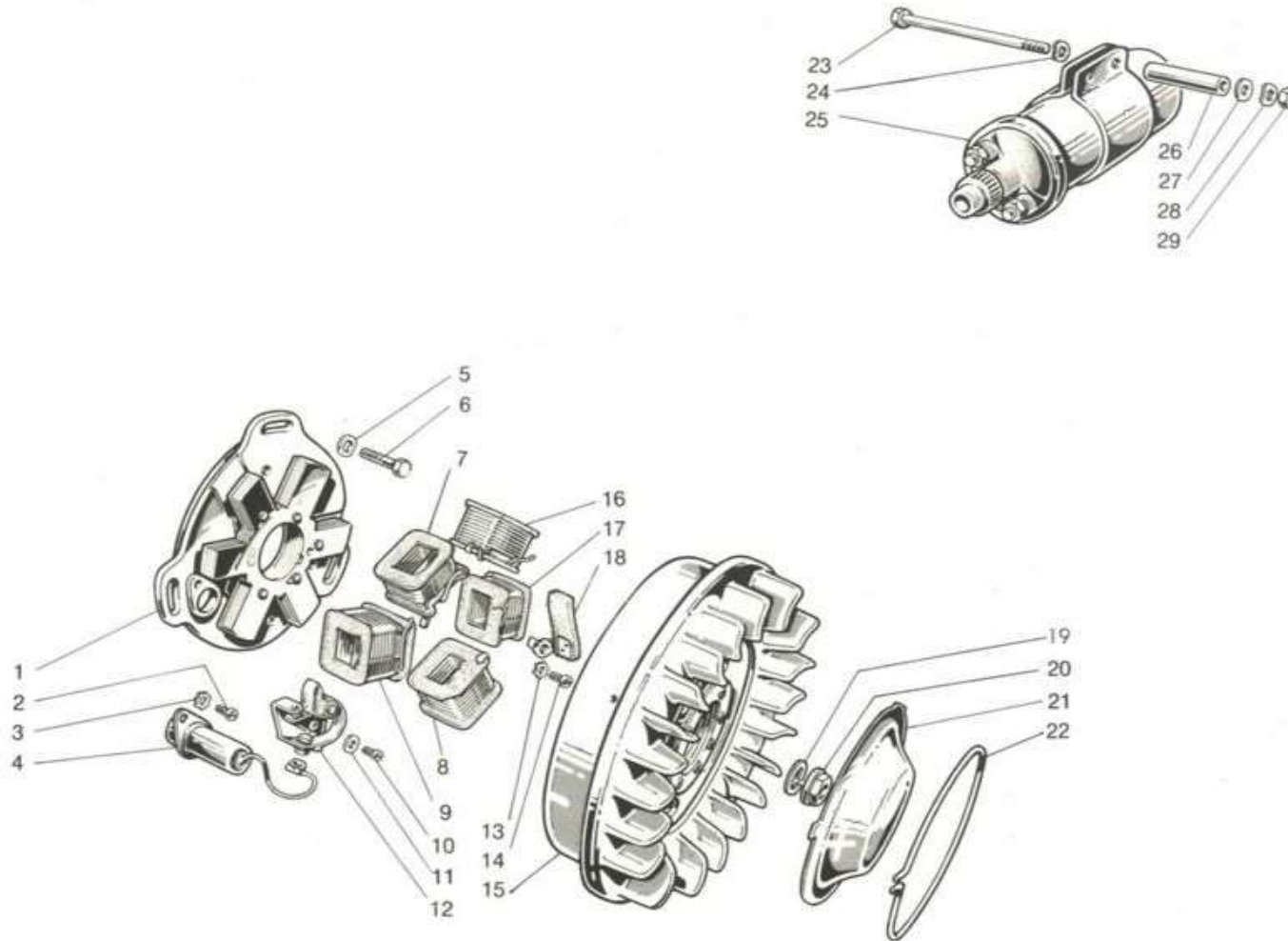

19 - 073



www.rpw.it
XV
XVI
XVII

Fig. Abb.	Ord. No. Bestell N.	Denominazione	Description	Désignation	Benennung	Qt. Anzahl							
							125 LI	125 S	150 LI	150 S	150 SX	175 TV	200 SX
1	19955081	Molla	Spring	Ressort	Feder	1	0	0	0	0	0	0	0
-	19955380 *	Maniglia D.	R.H. Handle	Poignée droite	Rechter Griff	1	0	0	0	0	0	0	0
-	19955370 *	Maniglia S.	L.H. Handle	Poignée gauche	Linker Griff	1	0	0	0	0	0	0	0
2	19955091	Leva	Lever	Levier	Hebel	2	0	0	0	0	0	0	0
3	19955088	Rondella distanziale	Distance washer	Rondelle d'entretoise	Abstandscheibe	2	0	0	0	0	0	0	0
4	19955350	Maniglia S.	L.H. Handle	Poignée gauche	Linker Griff	1	0	0	0	0	0	0	0
	19955360	Maniglia D.	R.H. Handle	Poignée droite	Rechter Griff	1	0	0	0	0	0	0	0
5	19955092	Spina	Pin	Pivot	Stift	2	0	0	0	0	0	0	0
6	71300512	Vite	Screw	Vis	Schraube	2	0	0	0	0	0	0	0
	71300522	Vite	Screw	Vis	Schraube	2	0	0	0	0	0	0	0
7	19955083	Flangia D.	R.H. Flange	Bride droite	Rechter Flansch	1	0	0	0	0	0	0	0
8	83100005	Rondella elastica	Spring washer	Rondelle élastique	Federscheibe	4	0	0	0	0	0	0	0
9	19955082	Flangia S.	L.H. Flange	Bride gauche	Linker Flansch	1	0	0	0	0	0	0	0
10	82108009	Dado	Nut	Ecrou	Mutter	4	0	0	0	0	0	0	0
11	19655190	Fiancata D.	R.H. Panel	Flanc droite	Rechte Seitenbekleidung	1							0
	19755190	Fiancata D.	R.H. Panel	Flanc droite	Rechte Seitenbekleidung	1		0		0	0	0	
	19955150	Fiancata D.	R.H. Panel	Flanc droite	Rechte Seitenbekleidung	1	0		0				
12	19950300	Listello D.	R.H. Strip	Baguette droite	Rechte Fussleiste	1	0	0	0	0	0	0	0
13	19950290	Listello D.	R.H. Strip	Baguette droite	Rechte Fussleiste	1	0	0	0	0	0	0	0
14	19950053	Pedana D.	Footboard R.H.	Repose-pied droite	Rechtes Fussbrett	1	0	0	0	0	0	0	0
15	15050052	Rondella	Washer	Rondelle	Scheibe	2	0	0	0	0	0	0	0
16	83100005	Rondella elastica	Spring washer	Rondelle élastique	Federscheibe	2	0	0	0	0	0	0	0
17	82058009	Dado	Nut	Ecrou	Mutter	2	0	0	0	0	0	0	0
18	19050098	Dado elastico	Spring nut	Ecrou élastique	Federmutter	2	0	0	0	0	0	0	0
19	19050111	Rondella elastica	Spring washer	Rondelle élastique	Federscheibe	2	0	0	0	0	0	0	0
20	82058009	Dado	Nut	Ecrou	Mutter	2	0	0	0	0	0	0	0
21	81008127	Vite	Screw	Vis	Schraube	1	0	0	0	0	0	0	0
22	73150053	Rondella	Washer	Rondelle	Scheibe	1	0	0	0	0	0	0	0
23	19955070	Parafango	Mudguard	Garde-boue	Kotflügel	1	0	0	0	0	0	0	0
24	19050111	Rondella elastica	Spring washer	Rondelle élastique	Federscheibe	1	0	0	0	0	0	0	0

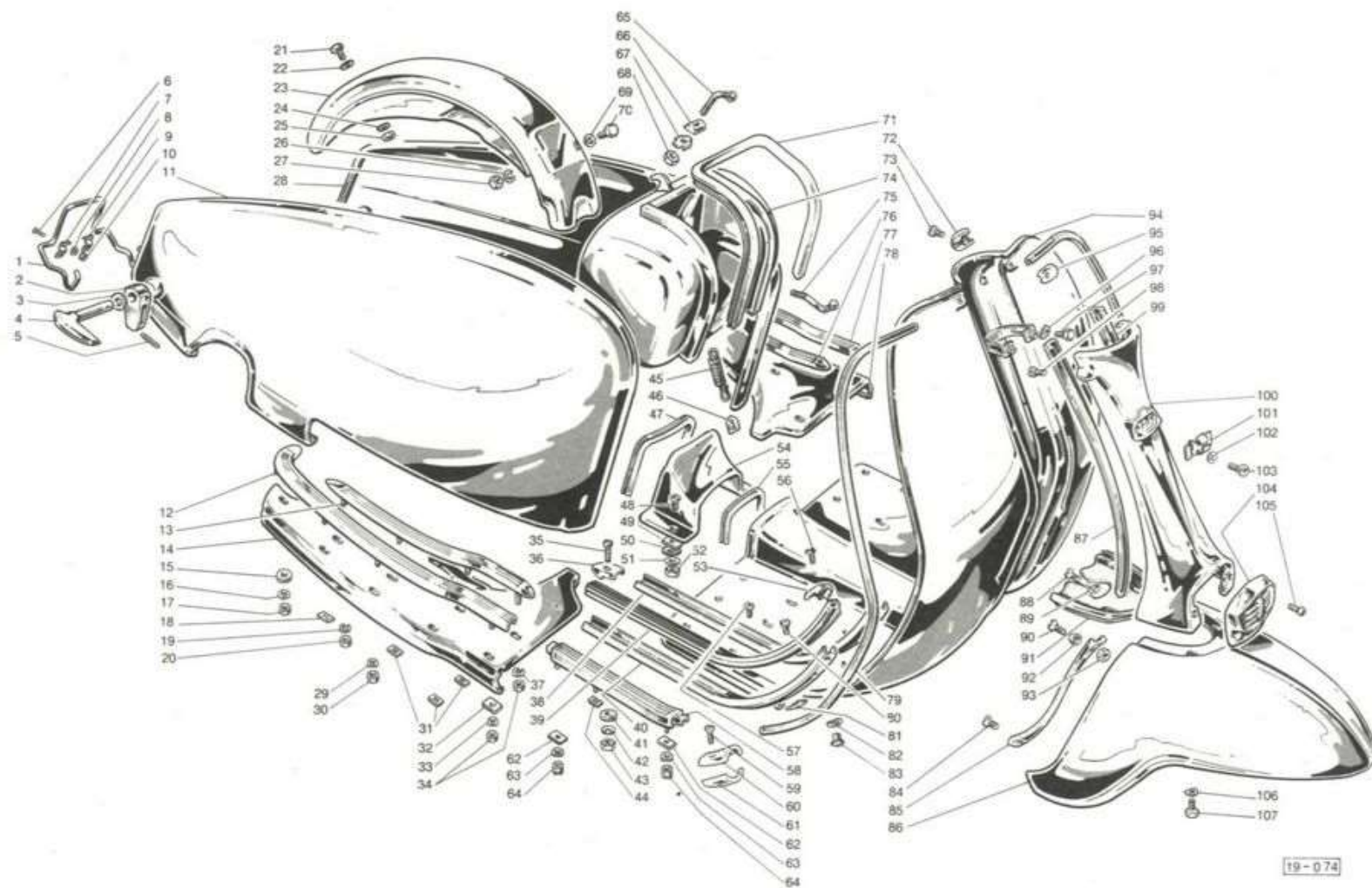

www.rpw.it
XV
XVI
XVII

Fig. Abb.	Ord. No. Bestell N.	Denominazione	Description	Désignation	Benennung	Qt. Anzahl	125 LI	125 S	150 LI	150 S	150 SX	175 TV	200 SX
25	82108009	Dado	Nut	Ecrou	Mutter	1	o	o	o	o	o	o	o
26	19050111	Rondella elastica	Spring washer	Rondelle élastique	Federscheibe	2	o	o	o	o	o	o	o
27	82108009	Dado	Nut	Ecrou	Mutter	2	o	o	o	o	o	o	o
28	19655180	Fiancata S.	L.H. Panel	Flanc gauche	Linke Seitenbekleidung	1							o
	19755180	Fiancata S.	L.H. Panel	Flanc gauche	Linke Seitenbekleidung	1		o		o	o	o	
	19955140	Fiancata S.	L.H. Panel	Flanc gauche	Linke Seitenbekleidung	1	o		o				
29	83100005	Rondella elastica	Spring washer	Rondelle élastique	Federscheibe	2	o	o	o	o	o	o	o
30	82058009	Dado	Nut	Ecrou	Mutter	2	o	o	o	o	o	o	o
31	19050098	Piastrina	Plate	Plaquette	Blech	6	o	o	o	o	o	o	o
32	19950052	Guarnizione	Gasket	Joint	Dichtung	2	o	o	o	o	o	o	o
33	83100005	Rondella elastica	Spring washer	Rondelle élastique	Federscheibe	2	o	o	o	o	o	o	o
34	82058009	Dado	Nut	Ecrou	Mutter	4	o	o	o	o	o	o	o
35	71450425	Vite	Screw	Vis	Schraube	4	o	o	o	o	o	o	o
36	19950094	Terminale	End cap	Borne	Endstück	4	o	o	o	o	o	o	o
37	19050111	Rondella elastica	Spring washer	Rondelle élastique	Federscheibe	2	o	o	o	o	o	o	o
38	19950091	Guaina S.	Channel L.H.	Gaine gauche	Führung links	1	o	o	o	o	o	o	o
	19950105	Guaina D.	Channel R.H.	Gaine droite	Führung rechts	1	o	o	o	o	o	o	o
39	19950093	Profilato	Rubber	Caoutchouc	Gummileiste	2	o	o	o	o	o	o	o
	19950101	Profilato	Rubber	Caoutchouc	Gummileiste	2	o	o	o	o	o	o	o
40	19950092	Guaina S.	Channel L.H.	Gaine gauche	Führung links	1	o	o	o	o	o	o	o
	19950106	Guaina D.	Channel R.H.	Gaine droite	Führung rechts	1	o	o	o	o	o	o	o
41	15050052	Rondella	Washer	Rondelle	Scheibe	4	o	o	o	o	o	o	o
42	19050104	Rondella	Washer	Rondelle	Scheibe	4	o	o	o	o	o	o	o
43	82058007	Dado	Nut	Ecrou	Mutter	4	o	o	o	o	o	o	o
44	19050098	Dado elastico	Spring nut	Ecrou élastique	Federmutter	2	o	o	o	o	o	o	o
45	15086016	Molla	Spring	Ressort	Feder	1	o	o	o	o	o	o	o
46	15086015	Piastrina	Plate	Plaquette	Blech	1	o	o	o	o	o	o	o
47	19950073	Guarnizione	Gasket	Joint	Dichtung	1	o	o	o	o	o	o	o
48	71420520	Vite	Screw	Vis	Schraube	2	o	o	o	o	o	o	o
49	19950052	Guarnizione	Gasket	Joint	Dichtung	2	o	o	o	o	o	o	o

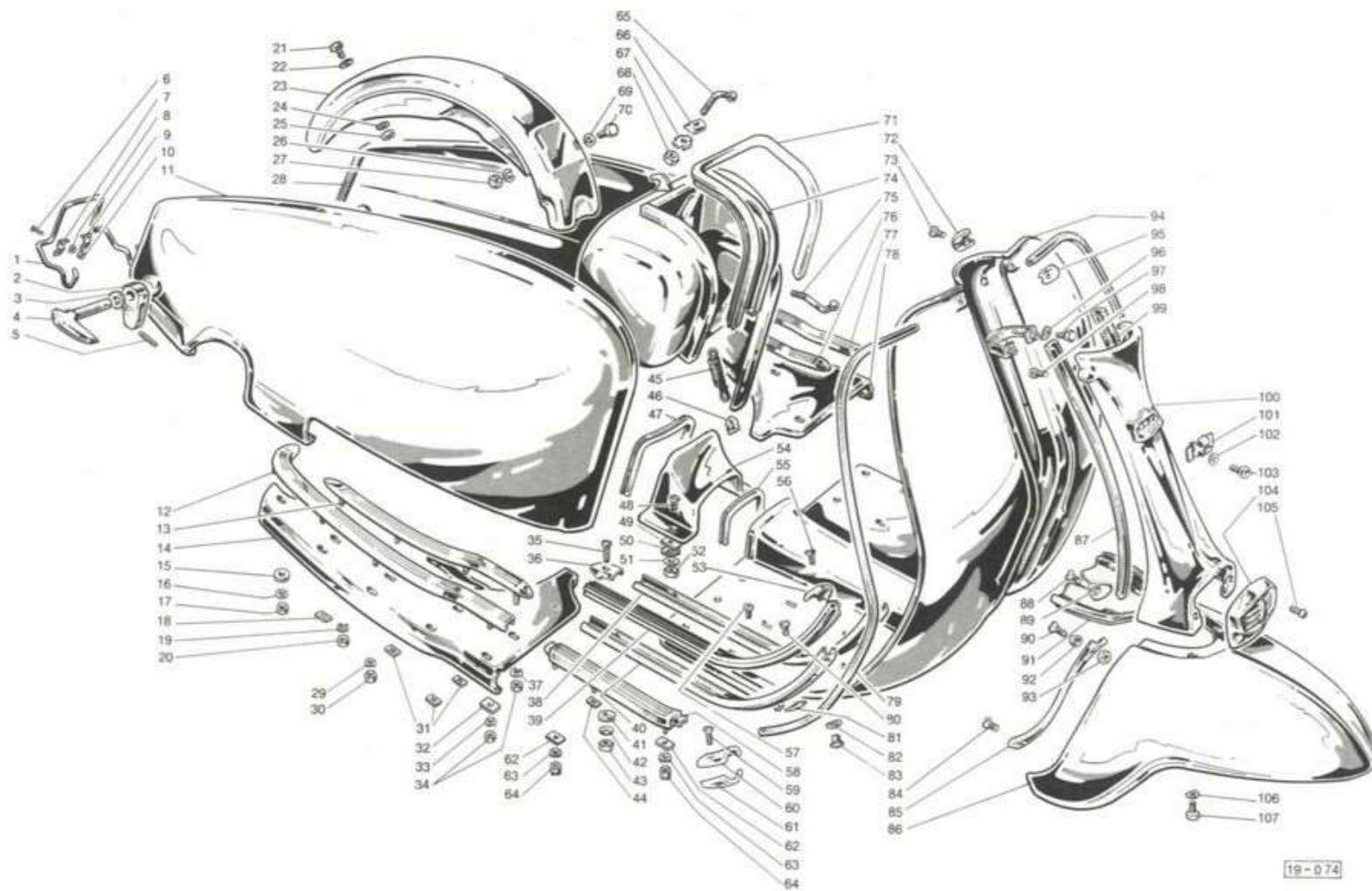

19-074

www.rpw.it

XVI
XVII



Fig. Abb.	Ord. No. Bestell N.	Denominazione	Description	Désignation	Benennung	Qt. Anzahl							
							125 L1	125 S	150 L1	150 S	150 SX	175 TV	200 SX
50	15050052	Rondella	Washer	Rondelle	Scheibe	2	o	o	o	o	o	o	o
51	19050111	Rondella elastica	Spring washer	Rondelle élastique	Federscheibe	2	o	o	o	o	o	o	o
52	82058009	Dado	Nut	Ecrou	Mutter	2	o	o	o	o	o	o	o
53	19950094	Terminale	End cap	Borne	Endstück	2	o	o	o	o	o	o	o
	19950103	Terminale	End cap	Borne	Endstück	2	o	o	o	o	o	o	o
54	19950072	Mascherina	Connecting piece	Raccord	Abdeckblech	1	o	o	o	o	o	o	o
55	15050058	Guarnizione	Gasket	Joint	Dichtung	1	o	o	o	o	o	o	o
56	71420410	Vite per 19950103	Screw	Vis	Schraube	2	o	o	o	o	o	o	o
	71450428	Vite per 19950094	Screw	Vis	Schraube	2	o	o	o	o	o	o	o
57	19050097	Vite	Screw	Vis	Schraube	4	o	o	o	o	o	o	o
58	19950220	Listello S.	L.H. Strip	Baguette gauche	Linke Fussleiste	1	o	o	o	o	o	o	o
	19950230	Listello D.	R.H. Strip	Baguette droite	Rechte Fussleiste	1	o	o	o	o	o	o	o
59	71480418	Vite	Screw	Vis	Schraube	2	o	o	o	o	o	o	o
60	19950087	Raccordo S.	Union L.H.	Raccord gauche	Verbindung Links	1	o	o	o	o	o	o	o
	19950089	Raccordo D.	Union R.H.	Raccord droite	Verbindung Rechts	1	o	o	o	o	o	o	o
61	19950088	Basetta S.	Base L.H.	Base gauche	Unterlage links	1	o	o	o	o	o	o	o
	19950095	Basetta D.	Base R.H.	Base droite	Unterlage rechts	1	o	o	o	o	o	o	o
62	19950052	Guarnizione	Gasket	Joint	Dichtung	4	o	o	o	o	o	o	o
63	83100005	Rondella elastica	Spring washer	Rondelle élastique	Federscheibe	4	o	o	o	o	o	o	o
64	19950112	Dado	Nut	Ecrou	Mutter	4	o	o	o	o	o	o	o
65	19986017	Tirante	Tie rod	Tirant	Zugstange	1	o	o	o	o	o	o	o
66	15086006	Piastrina	Plate	Plaquette	Blech	3	o	o	o	o	o	o	o
67	15086008	Piastrina sicurezza	Locking plate	Plaquette de blocage	Sicherungsblech	3	o	o	o	o	o	o	o
68	82058009	Dado	Nut	Ecrou	Mutter	3	o	o	o	o	o	o	o
69	73150053	Rondella	Washer	Rondelle	Scheibe	2	o	o	o	o	o	o	o
70	81008127	Vite	Screw	Vis	Schraube	2	o	o	o	o	o	o	o
71	19086018	Guarnizione	Gasket	Joint	Dichtung	1	o	o	o	o	o	o	o
72	19950064	Semipuntalino	Semicap	Embout	Halbstrebe	2	o	o	o	o	o	o	o
73	71420416	Vite	Screw	Vis	Schraube	2	o	o	o	o	o	o	o
74	19986010	Bauletto	Luggage-box	Coffret	Kasten	1	o	o	o	o	o	o	o

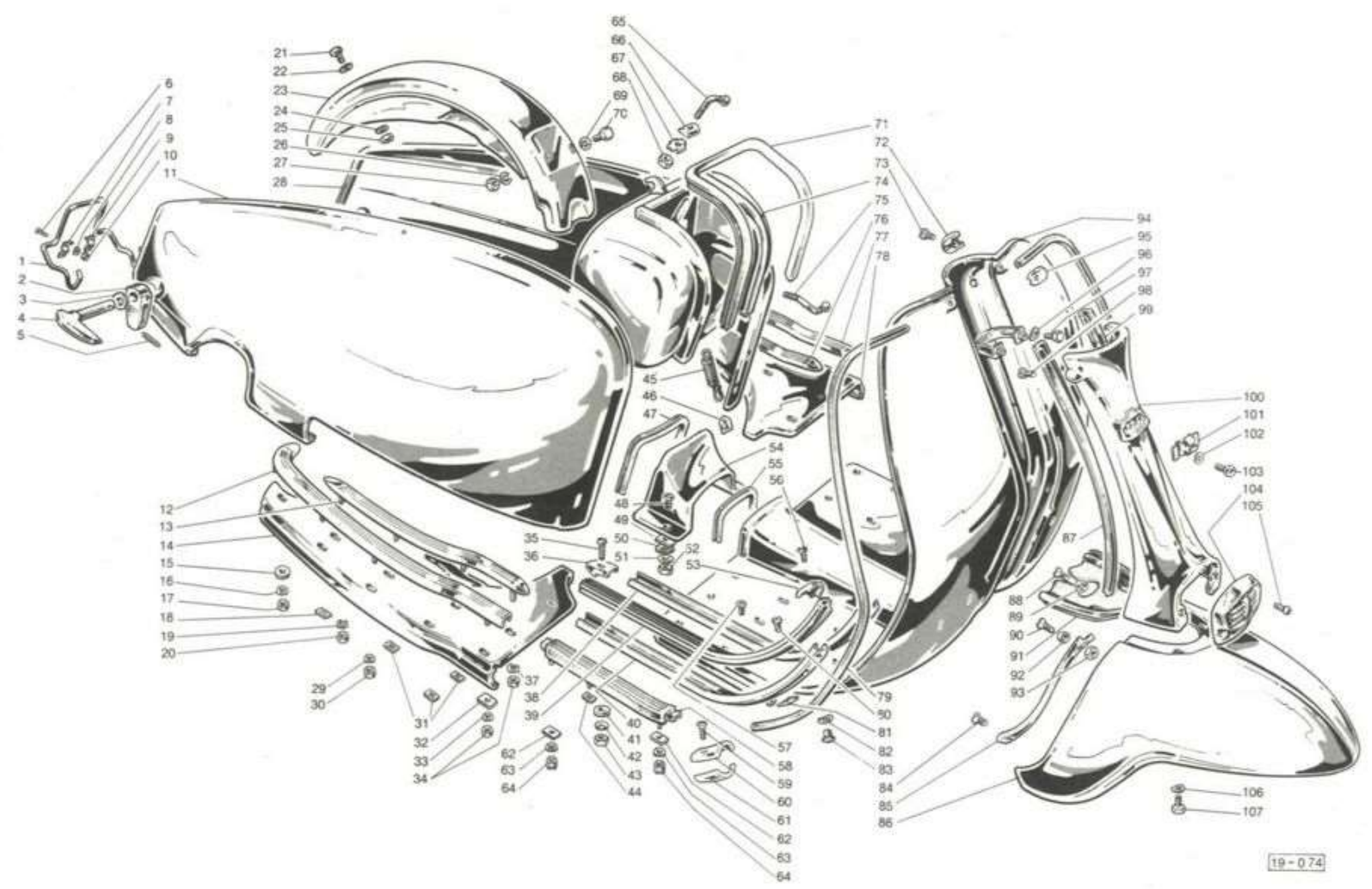

19-074

www.rpw.it

XVI

XVII



Fig. Abb.	Ord. No. Bestell N.	Denominazione	Description	Désignation	Benennung	Qt. Anzahl	125 LI	125 S	150 LI	150 S	150 SX	175 TV	200 SX
75	15086017	Tirante	Tie rod	Tirant	Zugstange	2	o	o	o	o	o	o	o
76	19950270	Listello S.	L.H. Strip	Baguette gauche	Linke Fussleiste	1	o	o	o	o	o	o	o
77	19950280	Listello S.	L.H. Strip	Baguette gauche	Linke Fussleiste	1	o	o	o	o	o	o	o
78	19950054	Pedana S.	L.H. Footboard	Repose-pied gauche	Linkes Fussbrett	1	o	o	o	o	o	o	o
79	19950062	Profilato	Finisher	Garniture	Leiste	2	o	o	o	o	o	o	o
80	19050097	Vite	Screw	Vis	Schraube	2	o	o	o	o	o	o	o
81	19050098	Dado	Nut	Ecrou	Mutter	6	o	o	o	o	o	o	o
82	83100006	Rondella elastica	Spring washer	Rondelle élastique	Federmutter	2	o	o	o	o	o	o	o
83	19050099	Dado per 71420410	Nut	Ecrou	Mutter	2	o	o	o	o	o	o	o
	82058007	Dado per 71450428	Nut	Ecrou	Mutter	2	o	o	o	o	o	o	o
84	71300520	Vite	Screw	Vis	Schraube	2	o	o	o	o	o	o	o
85	19750044	Guarnizione S.	L.H. Gasket	Joint gauche	Dichtung links	1		o		o	o	o	o
	19750045	Guarnizione D.	R.H. Gasket	Joint droite	Dichtung rechts	1		o		o	o	o	o
	19950044	Guarnizione S.	L.H. Joint	Joint gauche	Dichtung links	1	o		o				
	19950045	Guarnizione D.	R.H. Joint	Joint droite	Dichtung rechts	1	o		o				
86	19950060	Parafango anteriore	Front mudguard	Garde-boue av.	Kotflügel vorn	1		o		o		o	o
	19950530	Parafango anteriore	Front mudguard	Garde-boue av.	Kotflügel vorn	1					o		
	19950060	Parafango anteriore	Front mudguard	Garde-boue av.	Kotflügel vorn	1	o		o				
87	19950046	Guarnizione D.	R.H. Joint	Joint droite	Dichtung rechts	1	o	o	o	o	o	o	o
88	71420516	Vite	Screw	Vis	Schraube	2	o	o	o	o	o	o	o
89	15050066	Borchia	Boss	Rosette	Schildchen	2	o	o	o	o	o	o	o
90	71420520	Vite	Screw	Vis	Schraube	2	o	o	o	o	o	o	o
91	19950049	Guarnizione	Gasket	Joint	Dichtung	1	o	o	o	o	o	o	o
92	15050066	Borchia	Boss	Rosette	Schildchen	2	o	o	o	o	o	o	o
93	82058009	Dado	Nut	Ecrou	Mutter	2	o	o	o	o	o	o	o
94	19950110	Scudo	Legshield	Bouclier	Beinschild	1	o	o	o	o	o	o	o
95	19950063	Semipuntalino	Semicap	Embout	Halbstrebe	2	o	o	o	o	o	o	o
96	83100005	Rondella elastica	Spring washer	Rondelle élastique	Federscheibe	2	o	o	o	o	o	o	o
97	81008128	Vite	Screw	Vis	Schraube	2	o	o	o	o	o	o	o
98	19950108	Vite	Screw	Vis	Schraube	2	o	o	o	o	o	o	o

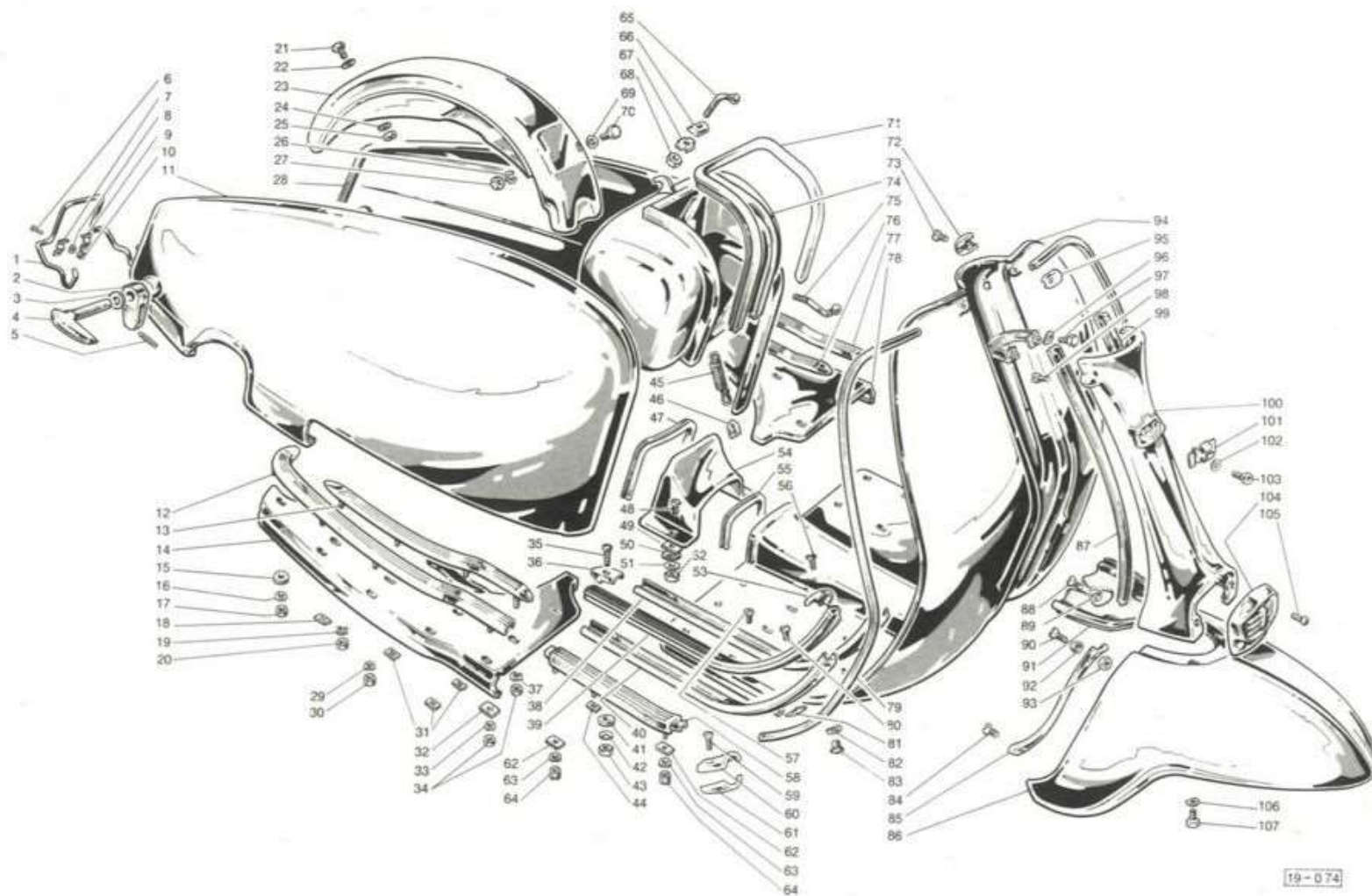

Carrozzeria

Body

Carrosserie

Aufbau

Tav. XV

Fig. Abb.	Ord. No. Bestell N.	Denominazione	Description	Désignation	Benennung	Qt. Anzahl	125 LI	125 S	150 LI	150 S	150 SX	175 TV	200 SX
99	19950047	Guarnizione S.	L.H. Joint	Joint gauche	Dichtung links	1	○	○	○	○	○	○	○
100	19750086	Frontale	Horncasting	Frontal	Gabelverkleidung	1		○		○	○	○	○
	19950086	Frontale	Horncasting	Frontal	Gabelverkleidung	1	○		○				
101	19950069	Molla	Spring	Ressort	Feder	1	○	○	○	○	○	○	○
102	73010064	Rondella	Washer	Rondelle	Scheibe	2	○	○	○	○	○	○	○
103	19950114	Vite	Screw	Vis	Schraube	2	○	○	○	○	○	○	○
104	19550504	Mascherina	Grille	Grille	Gitter	1					○		
	19750083	Mascherina	Grille	Grille	Gitter	1		○		○		○	○
	19950083	Mascherina	Grille	Grille	Gitter	1	○		○				
105	71300414	Vite	Screw	Vis	Schraube	2	○	○	○	○	○	○	○
106	83100005	Rondella	Washer	Rondelle	Scheibe	2	○	○	○	○	○	○	○
107	81008129	Vite	Screw	Vis	Schraube	2	○	○	○	○	○	○	○

* { con fig. with fig. avec fig. mit Abb. } 2-3-4-5

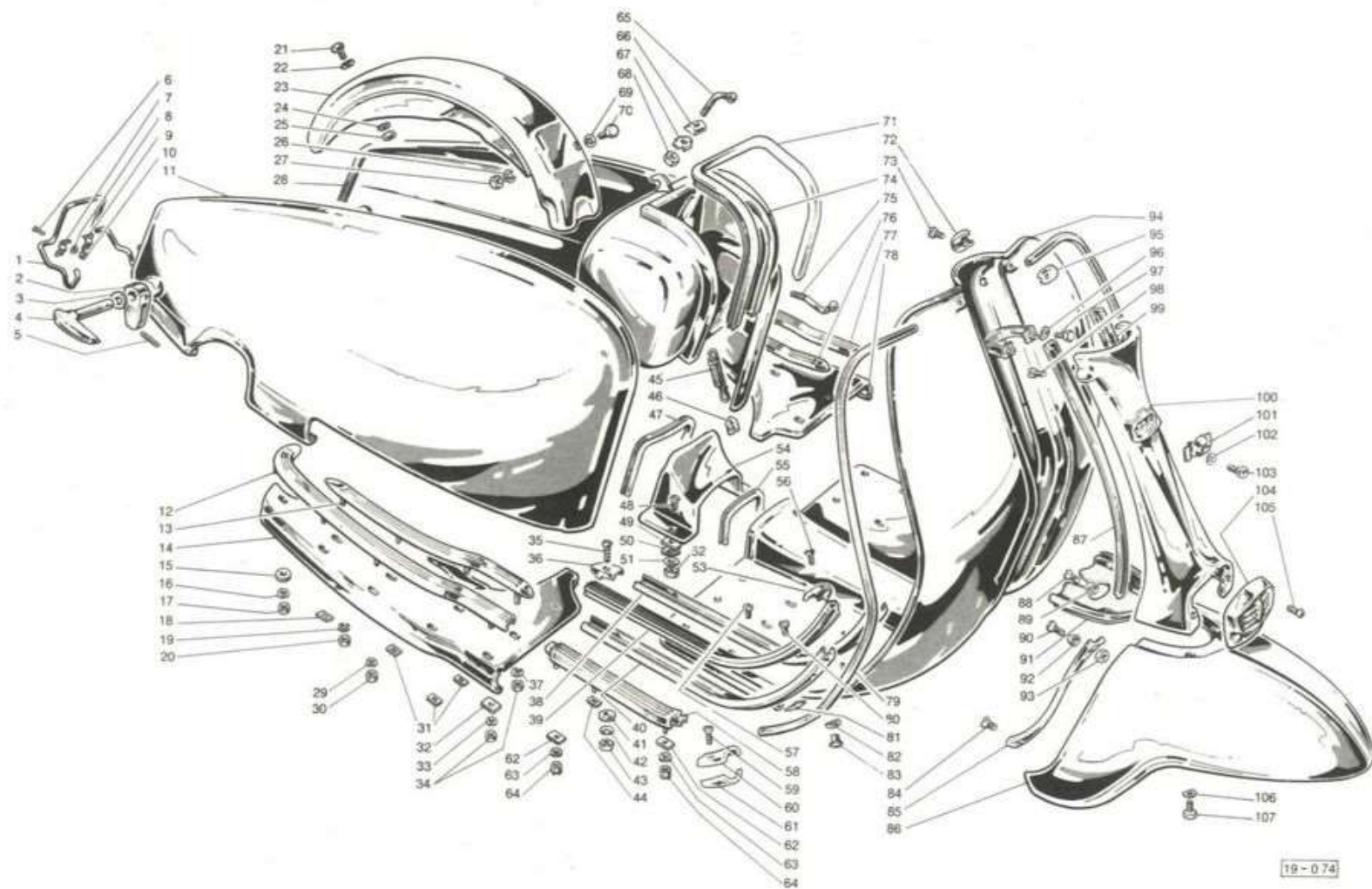
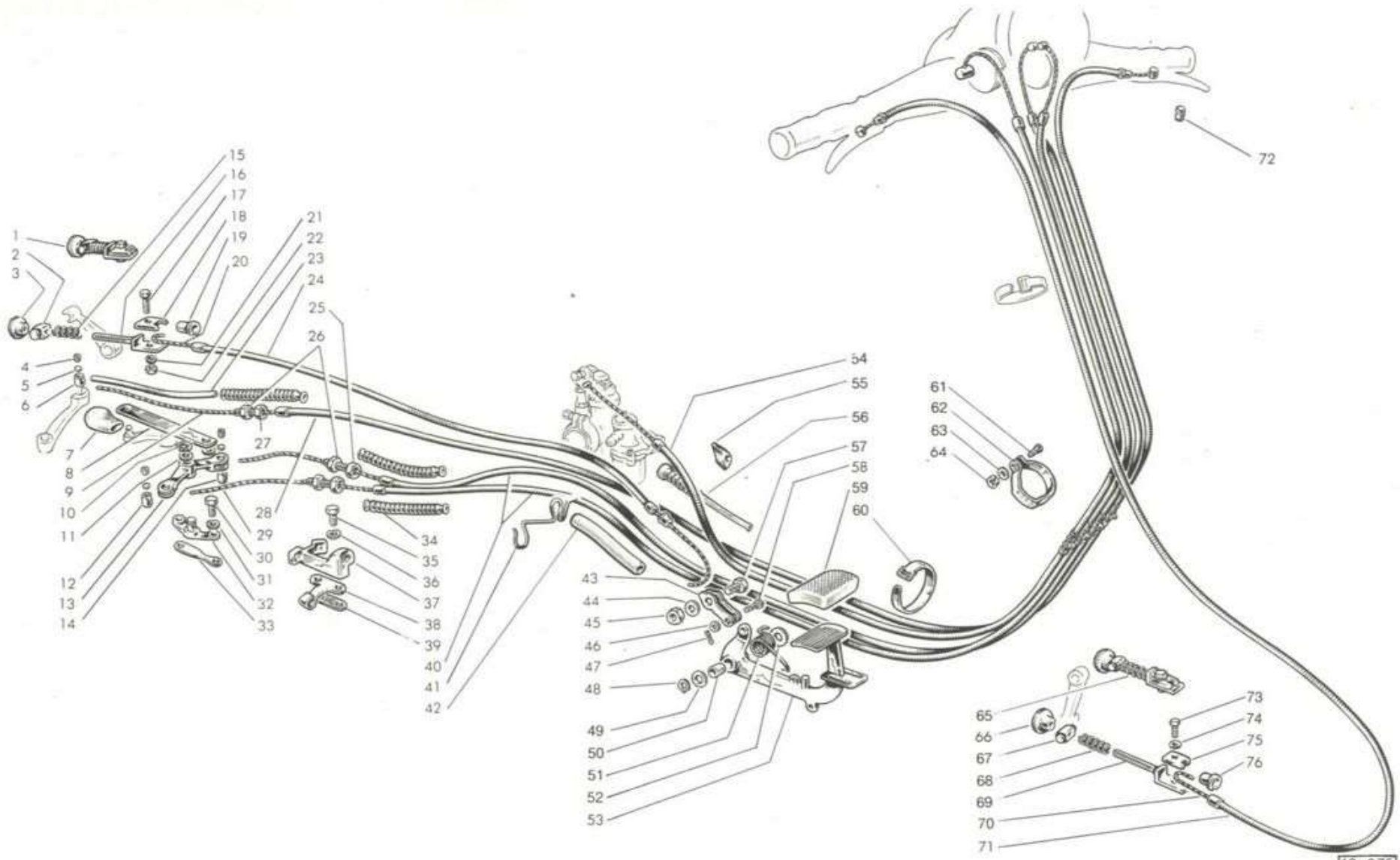

Fig. Abb.	Ord. No. Bestell N.	Denominazione	Description	Désignation	Benennung	Qt. Anzahl	125 LI	125 S	150 LI	150 S	150 SX	175 TV	200 SX
1	19059050	Regolazione	Adjuster	Réglage	Einstellung	1	0	0	0	0	0	0	0
2	19059001	Barilotto	Trunnion	Barillet	Gelenkstück	1	0	0	0	0	0	0	0
3	19059003	Ghiera	Adjuster ring	Ecrou moleté	Einstellmutter	1	0	0	0	0	0	0	0
4	15022009	Grano	Grub	Ergot	Gewindestift	3	0	0	0	0	0	0	0
5	15022011	Dischetto	Disc	Disque	Zwischenblech	3	0	0	0	0	0	0	0
6	15022008	Cilindretto	Trunnion	Barillet	Befestigungshülse	1	0	0	0	0	0	0	0
7	19032007	Cappuccio	Protection	Capuchon	Gummischutz	1	0	0	0	0	0	0	0
8	19032005	Tirante	Tie rod	Tirant	Zugstange	1	0	0	0	0	0	0	0
9	19022040	Fune frizione	Clutch inner cable	Câble int. embrayage	Kupplungsseil	1	0	0	0	0	0	0	0
10	73260010	Anello elastico	Circlip	Circlip	Seegerring	1	0	0	0	0	0	0	0
11	19031012	Rondella	Washer	Rondelle	Scheibe	2	0	0	0	0	0	0	0
12	15022008	Cilindretto	Trunnion	Barillet	Befestigungshülse	1	0	0	0	0	0	0	0
13	19031003	Leva	Lever	Levier	Hebel	1	0	0	0	0	0	0	0
14	19032003	Cilindretto	Trunnion	Barillet	Befestigungshülse	1	0	0	0	0	0	0	0
15	15065006	Molla	Spring	Ressort	Feder	1	0	0	0	0	0	0	0
16	19059015	Vite	Screw	Vis	Schraube	1	0	0	0	0	0	0	0
17	19059005	Vite	Screw	Vis	Schraube	1	0	0	0	0	0	0	0
18	19059016	Piastrina	Plate	Plaquette	Klemmblech	1	0	0	0	0	0	0	0
19	15059009	Capsula	Ferrule	Capsule	Sicherungshülse	2	0	0	0	0	0	0	0
20	19059011	Fune freno post.	Rear brake inner cable	Câble int. frein AR.	Hinterradbremsseil	1	0	0	0	0	0	0	0
21	83100007	Rondella elastica	Spring washer	Rondelle élastique	Federscheibe	1	0	0	0	0	0	0	0
22	19032008	Dado	Nut	Ecrou	Mutter	1	0	0	0	0	0	0	0
23	19022014	Protezione	Protection	Protection	Schutz	1	0	0	0	0	0	0	0
24	19959040	Cavo freno post.	Rear brake cable	Câble frein AR.	Hinterradbrems-Seilzug	1	0	0	0	0	0	0	0
25	19032001	Vite	Screw	Vis	Schraube	2	0	0	0	0	0	0	0
26	19032008	Dado	Nut	Ecrou	Mutter	3	0	0	0	0	0	0	0
27	19032001	Vite	Screw	Vis	Schraube	1	0	0	0	0	0	0	0
28	19022030	Cavo frizione	Clutch cable	Câble d'embrayage	Kupplungsseilzug	1	0	0	0	0	0	0	0
29	19032060	Fune cambio	Gear change inner cable	Câble int. commande vitesse	Schaltungsseil	2	0	0	0	0	0	0	0
30	81008159	Vite	Screw	Vis	Schraube	2	0	0	0	0	0	0	0



19-075



www.rpw.it

Fig. Abb.	Ord. No. Bestell N.	Denominazione	Description	Désignation	Benennung	Qt. Anzahl							
							125 LI	125 S	150 LI	150 S	150 SX	175 TV	200 SX
31	83100006	Rondella elastica	Spring washer	Rondelle élastique	Federscheibe	2	0	0	0	0	0	0	0
32	19031006	Perno	Pin	Pivot	Bolzen	1	0	0	0	0	0	0	0
33	19031004	Guarnizione	Gasket	Joint	Dichtung	1	0	0	0	0	0	0	0
34	19022015	Protezione	Protection	Protection	Gummimuffe	3	0	0	0	0	0	0	0
35	81008160	Vite	Screw	Vis	Schraube	2	0	0	0	0	0	0	0
36	83100006	Rondella elastica	Spring washer	Rondelle élastique	Federscheibe	2	0	0	0	0	0	0	0
37	19031017	Supporto	Support	Support	Halter	1	0	0	0	0	0	0	0
38	19059006	Piastrina	Plate	Plaquette	Blech	1	0	0	0	0	0	0	0
39	19032016	Guarnizione	Gasket	Joint	Dichtung	1	0	0	0	0	0	0	0
40	19032050	Cavo cambio	Gear change cable	Câble commande vitesse	Schaltungsseilzug	2	0	0	0	0	0	0	0
41	19932025	Deviatore cavi	Cable clip	Support de câble	Seilzügehalter	1	0	0	0	0	0	0	0
42	19090018	Tubetto	Tube	Tube	Gummimuffe	1	0	0	0	0	0	0	0
43	15059012	Tirante	Tie rod	Tirant	Zugstange	2	0	0	0	0	0	0	0
44	83100010	Rondella elastica	Spring washer	Rondelle élastique	Federscheibe	1	0	0	0	0	0	0	0
45	82118014	Dado	Nut	Ecrou	Mutter	1	0	0	0	0	0	0	0
46	73030064	Rondella	Washer	Rondelle	Scheibe	1	0	0	0	0	0	0	0
47	74400228	Copiglia	Split pin	Goupille	Splint	1	0	0	0	0	0	0	0
48	73260012	Anello elastico	Circlip	Circlip	Seegerring	1	0	0	0	0	0	0	0
49	83010012	Rondella	Washer	Rondelle	Scheibe	1	0	0	0	0	0	0	0
50	20074002	Bussola	Bush	Bague	Büchse	1	0	0	0	0	0	0	0
51	19059017	Molla	Spring	Ressort	Feder	1	0	0	0	0	0	0	0
52	15059006	Rondella	Washer	Rondelle	Scheibe	1	0	0	0	0	0	0	0
53	19959060	Pedale	Pedal	Pédale	Pedal	1	0	0	0	0	0	0	0
54	19915030	Cavo gas	Throttle cable	Câble commande gas	Vergaser-Seilzug	1	0	0	0	0	0	0	0
55	15017006	Passacavo	Grommet	Passe-câble	Gummitülle	1	0	0	0	0	0	0	0
56	15059022	Protezione	Protection	Protection	Gummimuffe	1	0	0	0	0	0	0	0
57	15059013	Perno	Pin	Pivot	Bolzen	1	0	0	0	0	0	0	0
58	15059014	Pernetto	Pin	Pivot	Bolzen	1	0	0	0	0	0	0	0
59	15059003	Protezione	Protection	Protection	Gummimuffe	1	0	0	0	0	0	0	0
60	86500300	Fascetta	Band	Collier	Schelle	4	0	0	0	0	0	0	0

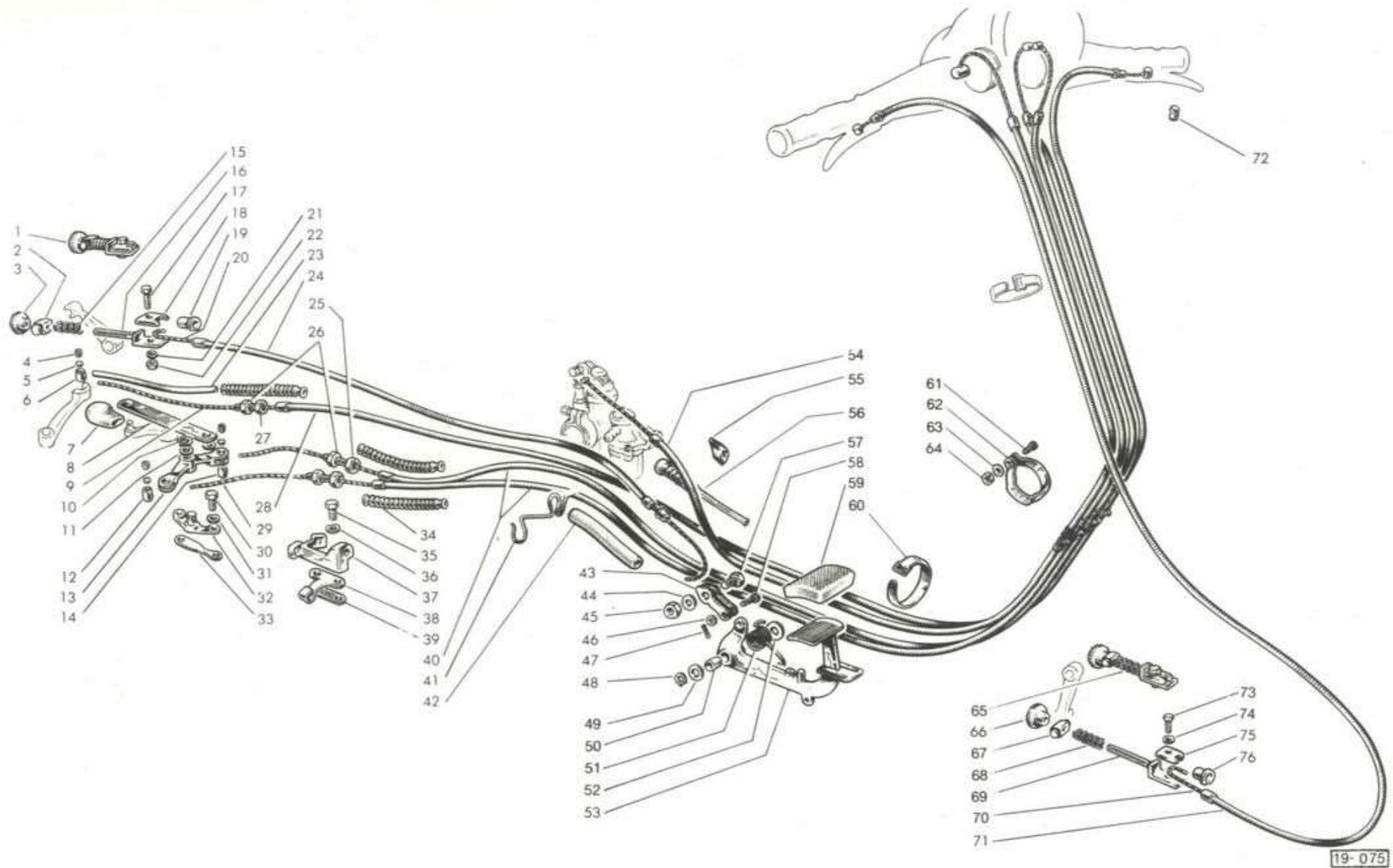

19-075



www.rpw.it

Fig. Abb.	Ord. No. Bestell N.	Denominazione	Description	Désignation	Benennung	Qt. Anzahl	125 LI	125 S	150 LI	150 S	150 SX	175 TV	200 SX
61	70850516	Vite	Screw	Vis	Schraube	1	o	o	o	o	o	o	o
62	19990011	Fascetta	Band	Collier	Schelle	1	o	o	o	o	o	o	o
63	83110005	Rondella elastica	Spring washer	Rondelle élastique	Federscheibe	1	o	o	o	o	o	o	o
64	82058009	Dado	Nut	Ecrou	Mutter	1	o	o	o	o	o	o	o
65	15065020	Regolazione	Adjuster	Réglage	Einstellung	1	o	o	o	o	o	o	o
66	19059003	Ghiera	Adjuster ring	Ecrou moleté	Einstellmutter	1	o	o	o	o	o	o	o
67	15065005	Barilotto	Trunnion	Barillet	Gelenkstück	1	o	o	o	o	o	o	o
68	15065006	Molla	Spring	Ressort	Feder	1	o	o	o	o	o	o	o
69	15065004	Vite	Screw	Vis	Schraube	1	o	o	o	o	o	o	o
70	19065070	Fune freno ant.	Front brake inner cable	Câble intérieur frein av.	Vorderbremsseil	1	o	o	o	o	o	o	o
71	19065060	Cavo freno ant.	Front brake cable	Câble frein av.	Vorderbremsseilzug	1	o	o	o	o	o	o	o
72	19022016	Cilindretto per fig. 9-70	Trunnion	Barillet	Befestigungshülse	2	o	o	o	o	o	o	o
73	81008128	Vite	Screw	Vis	Schraube	1	o	o	o	o	o	o	o
74	83120005	Rondella elastica	Spring washer	Rondelle élastique	Federscheibe	1	o	o	o	o	o	o	o
75	15065008	Piastrina	Plate	Plaquette	Klemmblech	1	o	o	o	o	o	o	o
76	85701035	Capsula	Ferrule	Capsule	Sicherungshülse	1	o	o	o	o	o	o	o

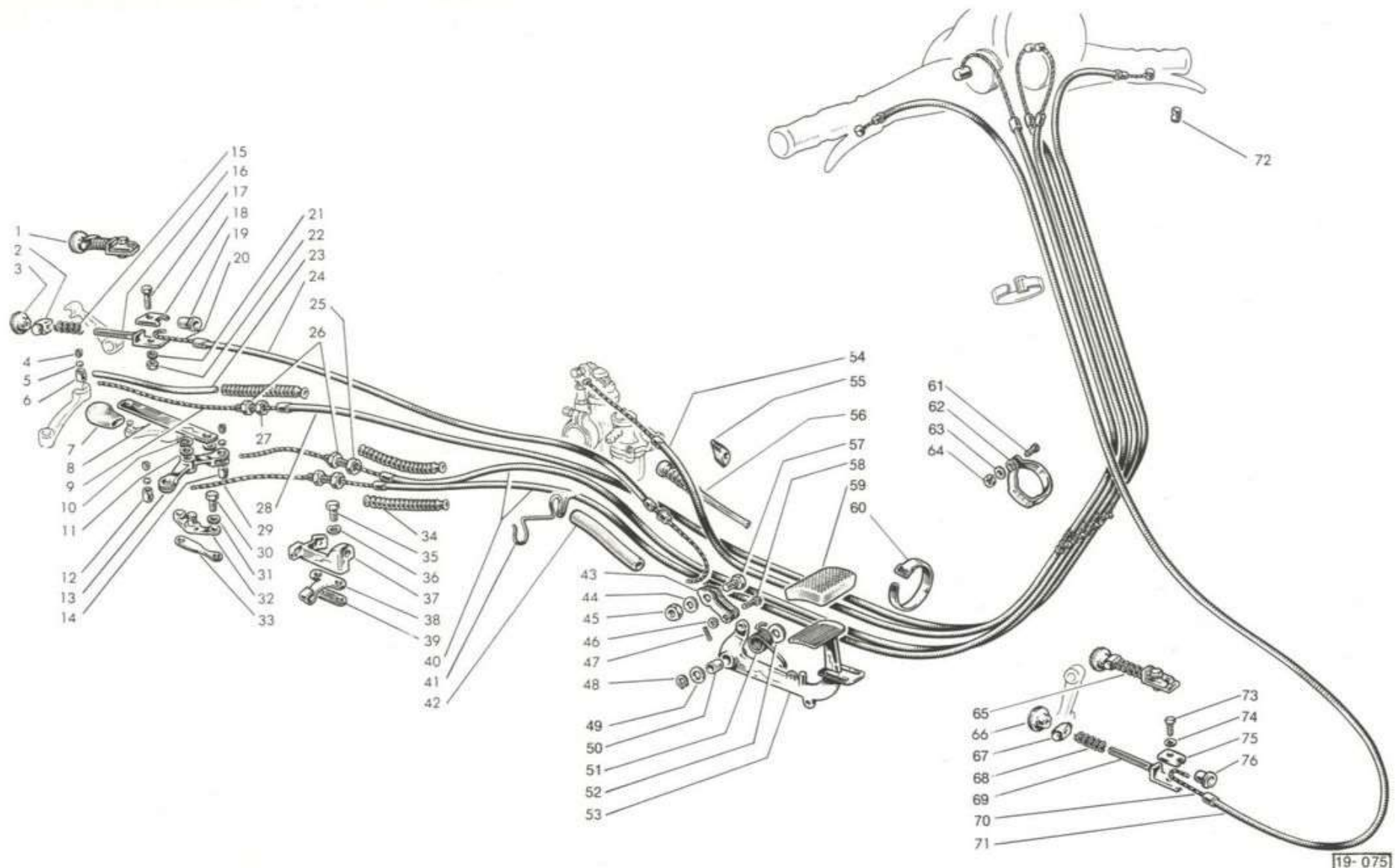

19-075



www.rpw.it

Fig. Abb.	Ord. No. Bestell N.	Denominazione	Description	Désignation	Benennung	Qt. Anzahl	125 LI	125 S	150 LI	150 S	150 SX	175 TV	200 SX
1	—	* Sella posteriore	Rear saddle	Selle ar.	Hintersattel	—							
2	19055290	Maniglia	Handgrip	Poignée	Griff	1	o		o				
3	19055250	Sella anteriore	Front saddle	Selle av.	Vordersattel	1	o		o				
4	81008244	Vite	Screw	Vis	Schraube	4	o		o				
5	19955056	Rondella	Washer	Rondelle	Scheibe	8	o		o				
6	83100008	Rondella elastica	Spring washer	Rondelle élastique	Federscheibe	4	o		o				
7	82058012	Dado	Nut	Ecrou	Mutter	4	o		o				
8	81008222	Vite	Screw	Vis	Schraube	4	o		o				
9	19055056	Rondella	Washer	Rondelle	Scheibe	4	o		o				
10	83100008	Rondella elastica	Spring washer	Rondelle élastique	Federscheibe	4	o		o				
11	82058012	Dado	Nut	Ecrou	Mutter	4	o		o				
12	19555140	Sella biposto verde	Dual seat green	Selle biplace vert	Sitzbank grün	1	o	o	o	o	o	o	o
	19555150	Sella biposto bleu scuro	Dual seat dark blue	Selle biplace bleu obscur	Sitzbank dunkelblau	1	o	o	o	o	o	o	o
	19555160	Sella biposto bleu chiaro	Dual seat light blue	Selle biplace bleu clair	Sitzbank hellblau	1	o	o	o	o	o	o	o
	19655150	Sella biposto rosso	Dual seat red	Selle biplace rouge	Sitzbank rot	1	o	o	o	o	o	o	o
13	15055170	Maniglia	Handgrip	Poignée	Griff	1	o	o	o	o	o	o	o
14	19955093	Targhetta	Name plate	Ecritéau	Firmenzeichen	1	o	o	o	o	o	o	o
15	19955010	Modanatura	Finisher	Moulure	Zierstück	1	o	o	o	o	o	o	o
16	19955015	Cavallotto	Stirrup	Etrier	Krampe	2	o	o	o	o	o	o	o
17	83100005	Rondella elastica	Spring washer	Rondelle élastique	Federscheibe	2	o	o	o	o	o	o	o
18	82058009	Dado	Nut	Ecrou	Mutter	2	o	o	o	o	o	o	o
19	82108009	Dado	Nut	Ecrou	Mutter	2	o	o	o	o	o	o	o
20	83100005	Rondella elastica	Spring washer	Rondelle élastique	Federscheibe	2	o	o	o	o	o	o	o
21	71300522	Vite	Screw	Vis	Schraube	2	o	o	o	o	o	o	o
22	19990003	Distanziale	Distance piece	Entretoise	Distanzrohr	2	o	o	o	o	o	o	o
23	19990002	Paraspruzzi	Mud flap	Bavolet	Schmutzfänger	1	o	o	o	o	o	o	o
24	19755074	Modanatura sinistra	Finisher L.H.	Moulure gauche	Zierstück links	1		o		o	o	o	o
	19755075	Modanatura destra	Finisher R.H.	Moulure droite	Zierstück rechts	1		o		o	o	o	o
25	19955051	Dicitura	Name plate	Ecritéau	Firmenzeichen	2	o	o	o	o	o	o	o
26	19986220	Chiave per candela	Spanner for spark plug	Clef pour bougie	Schlüssel für Zündkerze	1	o	o	o	o	o	o	o

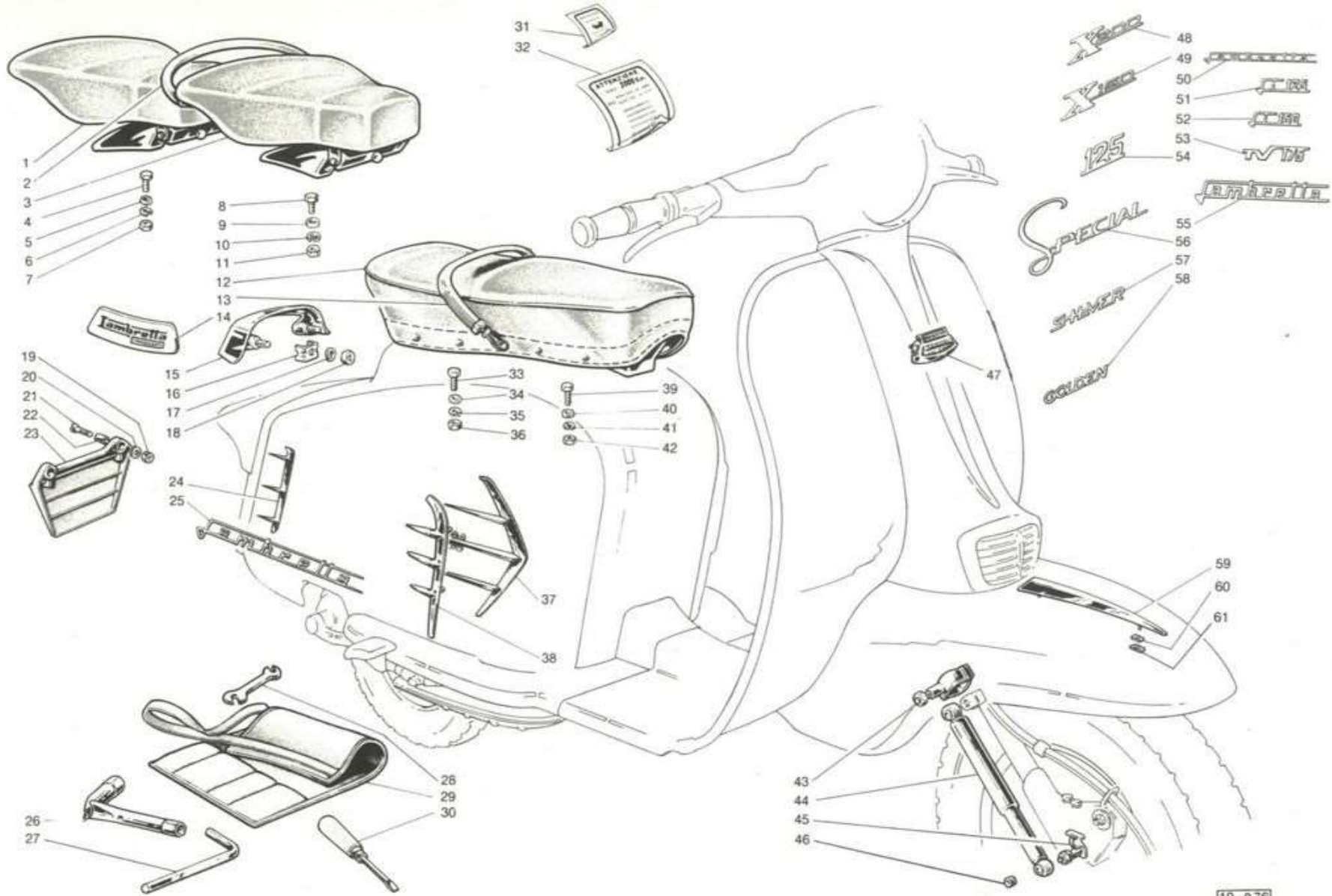

19-076

INNOCENTI

www.fpw.it

Fig. Abb.	Ord. No. Bestell N.	Denominazione	Description	Désignation	Benennung	Qt. Anzahl	125 LI	125 S	150 LI	150 S	150 SX	175 TV	200 SX
27	19086067	Chiave per tappi	Allen key	Clef pour bouchon	Schlüssel für Zapfen	1	o	o	o	o	o	o	o
28	15086061	Chiave 8/10	Spanner 8/10	Clef 8/10	Schlüssel 8/10	1	o	o	o	o	o	o	o
29	19986290	Borsa attrezzi	Tool bag	Trousse à outils	Werkzeugtasche	1	o	o	o	o	o	o	o
30	42986023	Cacciavite	Screw driver	Tournevis	Schraubenzieher	1	o	o	o	o	o	o	o
31	—	* Decalcomanie	Transfer	Décalcomanie	Abziehbild	—							
32	—	* Decalcomanie	Transfer	Décalcomanie	Abziehbild	—							
33	81008224	Vite	Screw	Vis	Schraube	4		o		o	o	o	o
34	19955056	Rondella	Washer	Rondelle	Scheibe	8		o		o	o	o	o
35	83100008	Rondella elastica	Spring washer	Rondelle élastique	Federscheibe	4		o		o	o	o	o
36	82058012	Dado	Nut	Ecrou	Mutter	4		o		o	o	o	o
37	19655076	Modanatura sinistra	Finisher L.H.	Moulure gauche	Zierstück links	1							o
	19655077	Modanatura destra	Finisher R.H.	Moulure droite	Zierstück rechts	1							o
38	19755076	Modanatura sinistra	Finisher L.H.	Moulure gauche	Zierstück links	1		o		o	o	o	
	19755077	Modanatura destra	Finisher R.H.	Moulure droite	Zierstück rechts	1		o		o	o	o	
39	81008122	Vite	Screw	Vis	Schraube	4		o		o	o	o	o
40	19055056	Rondella	Washer	Rondelle	Scheibe	4		o		o	o	o	o
41	83100008	Rondella elastica	Spring washer	Rondelle élastique	Federscheibe	4		o		o	o	o	o
42	82058012	Dado	Nut	Ecrou	Mutter	4		o		o	o	o	o
43	19060230	Attacco	Retainer	Support	Halter	2	o	o	o	o	o		
44	19060290	Ammortizzatore	Shock absorber	Amortisseur	Rückstosdämpfer	2	o	o	o	o	o		
45	19060240	Attacco sinistro	L.H. Retainer	Support gauche	Halter links	1	o	o	o	o	o		
	19060250	Attacco destro	R.H. Retainer	Support droite	Halter rechts	1	o	o	o	o	o		
46	19060280	Silentbloc	Silentblock	Silentbloc	Silentblock	4	o	o	o	o	o		
47	19250071	Marchio	Badge	Ecusson	Firmenschild	1	o	o	o	o	o	o	o
48	19650190	Dicitura	Model plate	Monogramme	Typzeichen	1							
49	19550520	Dicitura	Model plate	Monogramme	Typzeichen	1					o		
50	15050160	Dicitura	Name plate	Ecrêteau	Firmenzeichen	1	o		o				
51	19150200	Dicitura	Model plate	Monogramme	Typzeichen	1	o						
52	19050200	Dicitura	Model plate	Monogramme	Typzeichen	1			o				
53	15050200	Dicitura	Model plate	Monogramme	Typzeichen	1						o	

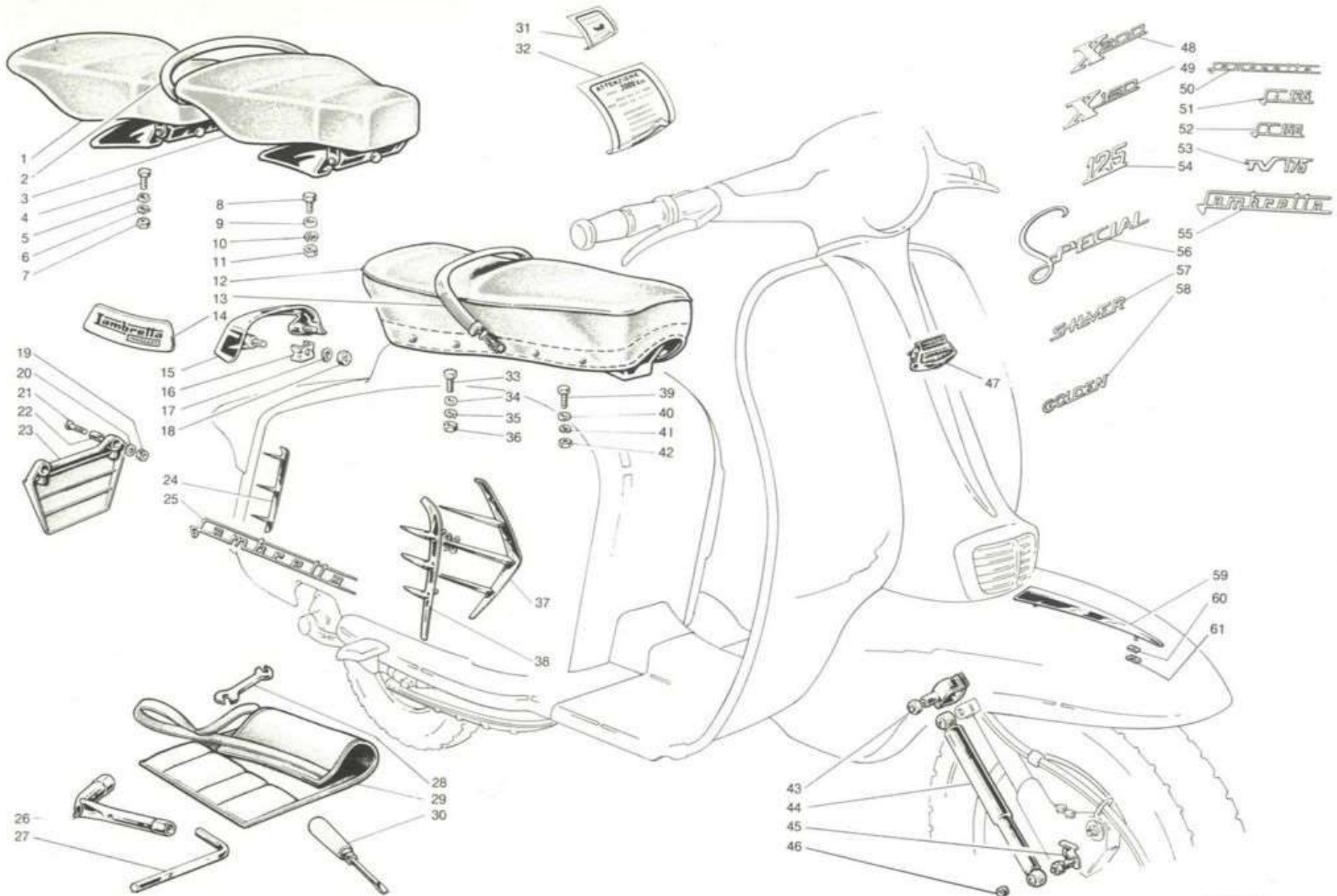

19-076

INNOCENTI

Accessori

Accessories

Accessoires

Zubehör

Tav. XVII

Fig. Abb.	Ord. No. Bestell N.	Denominazione	Description	Désignation	Benennung	Qt. Anzahl	125 LI	125 S	150 LI	150 S	150 SX	175 TV	200 SX
54	19450190	Dicitura	Model plate	Monogramme	Typzeichen	1		o					
55	19650170	Dicitura	Name plate	Ecritéau	Firmenzeichen	1		o		o	o		o
56	19550150	Dicitura	Model plate	Monogramme	Typzeichen	1		o		o	o		o
57	19550170	Dicitura	Model plate	Monogramme	Typzeichen	1				o			
58	19550160	Dicitura	Model plate	Monogramme	Typzeichen	1				o			
59	19550540	Modanatura	Finisher	Moulure	Zierstück	1					o		
60	19550503	Guarnizione	Gasket	Joint	Dichtung	2					o		
61	19050098	Piastrina	Plate	Plaquette	Blech	2					o		

★ Non si fornisce come ricambio. Is not supplied as a spare part. N'est pas fourni comme pièce détachée. Wird nicht als Ersatzteil geliefert.

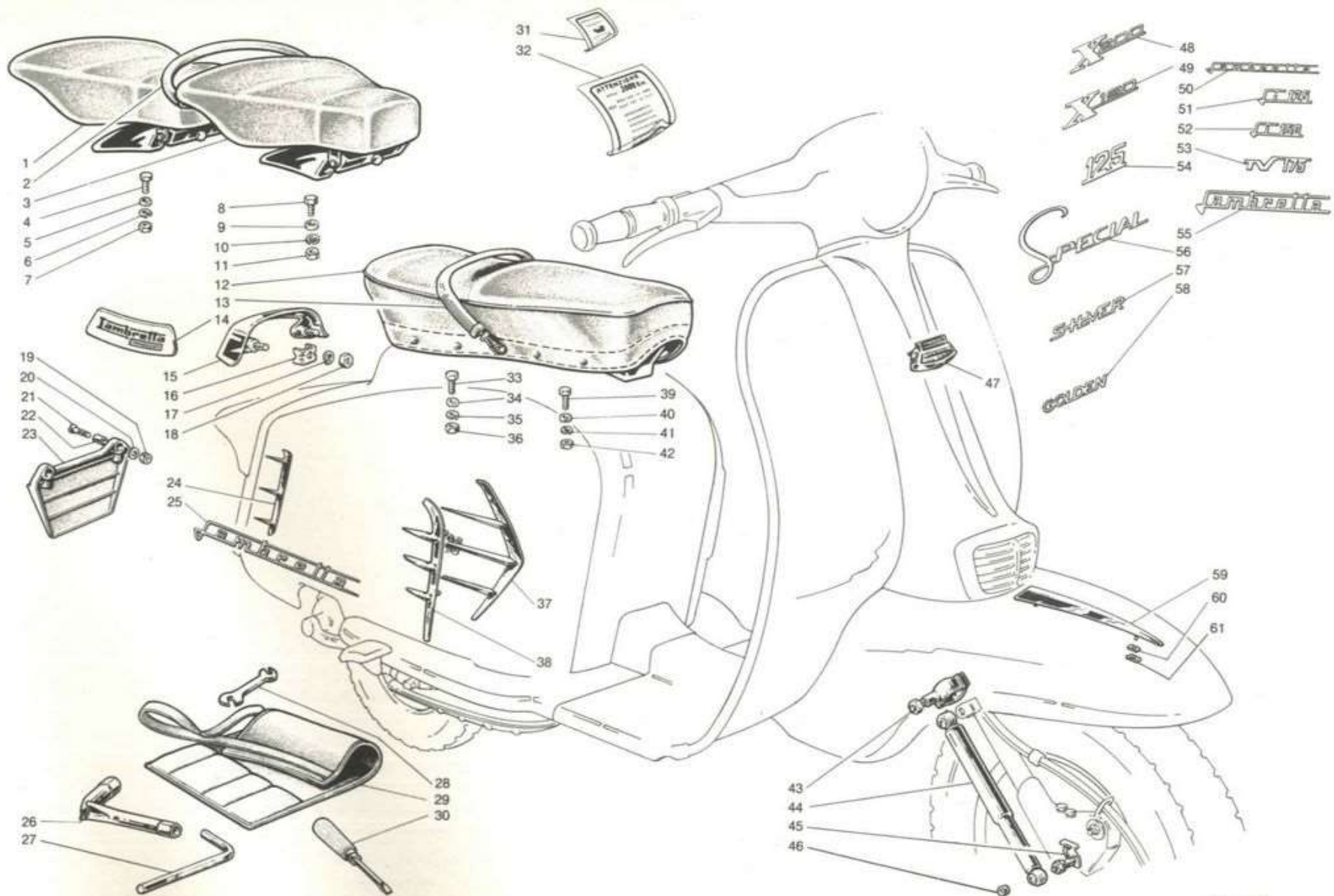

19-076

INNOCENTI

Copyright by « INNOCENTI » - Milano

Le denominazioni dei pezzi di ricambio, il testo ed il sistema di numerazione non possono essere stampati o tradotti né integralmente né parzialmente senza autorizzazione scritta della « INNOCENTI » - Milano.

The description of the spare parts, text and codification system cannot be reprinted or translated either fully or partially without written authorization from « INNOCENTI » - Milan.

La dénomination des pièces de rechange, le texte et le système de numération ne peuvent, en aucun cas, être ré-imprimés ou traduits intégralement ou partiellement sans autorisation écrite par « INNOCENTI » - Milan.

Die Benennung der Ersatzteile, Text und Numerierungs-System dürfen nicht wiedergedruckt, noch übersetzt werden, weder ganz oder auch nur teilweise, ohne vorherige schriftliche Genehmigung seitens « INNOCENTI » - Mailand.

120

INNOCENTI

SOC. GENERALE PER L'INDUSTRIA METALLURGICA E MECCANICA

MILANO ROMA NEW YORK PARIS LONDON CARACAS DÜSSELDORF